

1985

Ford LTD





Donald E. Petersen  
President

Ford Motor Company  
The American Road  
Dearborn, Michigan 48121

Dear New Car Buyer:

Quality is Job 1 at Ford Motor Company. This isn't just a phrase. It's a commitment to total quality.

Total quality begins with the design and engineering of our cars and continues through the life of the product. We plan them with a vision of the customer — of you — sitting behind the wheel of a new car.

Total quality will be apparent to you through functional performance, overall vehicle integrity, the "look and feel" of materials, satisfying aesthetics, safety, serviceability and cost of ownership.

Total quality requires continuous improvement in everything we do. Every employee at Ford Motor Company is involved in the process of meeting your needs and expectations.

I think the 1985 Ford LTD is an excellent example of the quality I'm talking about. It's a comfortable family car in either sedan or wagon models, but also a capable road car with its gas-filled shock absorbers and rack and pinion steering. The LX model's V-8 engine and special suspension offer an extra measure of performance.

I invite you to look over our new 1985 Ford cars in your dealer's showroom. Test drive them on the road. When you do, I think you'll understand all that's involved in the total quality concept at Ford Motor Company.

A handwritten signature in cursive script that reads "Donald E. Petersen".

Donald E. Petersen  
President  
Ford Motor Company

# Ford LTD for 1985



**LTD 4-Door Sedan** offers comfort and capable performance in a quiet-riding, family-sized automobile. It features a high level of standard equipment that includes gas-filled shocks and struts to help smooth the ride.



**LTD Brougham**, with the Interior Luxury Group, combines many extra driving conveniences with premium upholstery and trim appointments; a high style of comfort.



**LTD LX** is a luxuriously appointed touring sedan with the emphasis on performance. In addition to a special handling suspension, the power of the 5.0 liter HO (High Output) V-8 engine is included.



**LTD Wagon** is an excellent blend of utility and comfort, offering a cargo volume index unsurpassed by any American-built wagon in its class. LTD Wagon is also available with the handsome Squire Option (as shown on page 13).

Ford LTD is a very satisfying family automobile. In fact, no other American car in its class has more completely satisfied owners.\* That's the result of Ford's total commitment to quality — quality that's exemplified in the performance capabilities and comfort of the new LTD.

## Contents

Quality and Workmanship . . . . .	4-5
Ride and Handling . . . . .	6-7
Power and Efficiency . . . . .	8-9
Ford LTD Environment . . . . .	10-11
Ford LTD and LTD Wagon . . . . .	12-13
Ford LTD Brougham . . . . .	14-15
Ford LTD LX . . . . .	16-19
Features, Options, Colors and Trims . . . . .	20-21
Safety Features . . . . .	22
Owner Information . . . . .	23

\*Based on a survey of new car buyers of 1983 models.

Front and back covers: LTD Brougham 4-Door Sedan (some equipment shown may be optional).

**A word about this catalog:** Some of the equipment shown or described throughout the catalog is available at extra cost.

# Quality and Workmanship

Ford Motor Company is committed to building cars that meet the high quality standards expected by those who drive them.

Every aspect of the car's design has a purpose, whether it be aerodynamic efficiency or interior comfort.

Engineering systems — the engine and suspension, for example — are

manufactured and assembled under strict quality controls.

The hood, doors, decklid, moldings — everything has stringent fit tolerances. The paint finish is smooth and lustrous.

Behind the quality of every Ford car are the dedicated people who produce it.

**Design and engineering, where quality begins.**

Quality demands that before a car can be built right, it must first be designed and engineered right.



Today, engineers can measure with amazing accuracy how a car responds to actual on-road conditions long before it is built. It's done with simulations of full-scale vehicles and individual components in action on computer screens.

Vehicles can be driven around pylons at various speeds, climb steep grades, run over potholes, just as they would be in real testing at a proving ground. The computer displays in close detail the intricate movements of the suspension and other systems. They're evaluated to high standards of performance, redesigned and retested if necessary.

Even with this advanced technology, however, the art of automotive design and engineering remains in the hands of designers and engineers. The computer is there to assist them.

### **Withstanding stress. The ultimate test of a car's quality.**

Drivers expect their cars to function properly in everyday use. So Ford cars are road-tested over hundreds of thousands of miles, are subjected to extreme stress and load conditions over paved and unpaved surfaces, up and down steep grades, through corrosive salt baths. They run the full course of demanding acceleration, cornering and braking maneuvers.

But even before these road tests, Ford engineers put prototype cars through numerous laboratory tests. The Electrodynamic Actuator, for example, drives a car continuously under a variety of road and weather conditions. One objective is to eliminate squeaks and rattles caused by bumps and jolts and the effects of hot and cold temperatures.

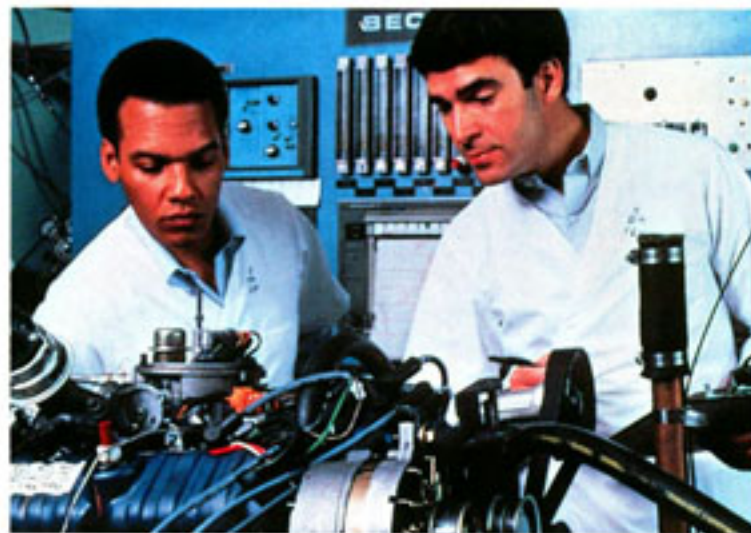

*LTD Brougham 4-Door Sedan shown with optional pivoting front vent windows, right-hand remote-control mirror, rear window defroster, bumper rub strips and styled road wheels.*



### **Computers, robots and lasers in manufacturing and assembly.**

Monitoring engine performance, checking electrical systems for accuracy, helping ensure smooth paint applications for finish quality — these are some of the vital roles that computers play in the assembly of Ford cars.

Ford places great importance also on robotics to achieve high quality in fit, finish and function. Robots are programmed to provide consistency and control to an extraordinary degree. They can do the 2,000 welds on a car's body quickly, completely, with the precision the blueprints demand.

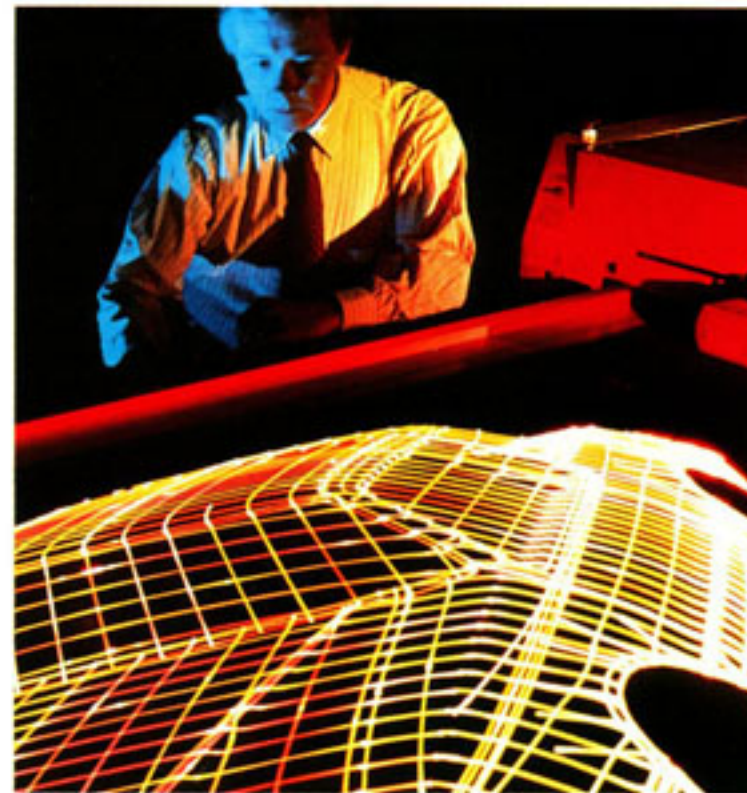

The laser, another advanced-technology tool, helps improve quality by providing accurate measurement of everything from engine castings and door margins to nuts and bolts and fasteners.

### **Special quality steps: Corrosion protection.**

Ford takes tough measures to protect its cars against the damaging effects of corrosion. Galvanized steel is used for important underbody and structural parts. Pre-coated steel, featuring corrosion inhibitors, is also used in major body panels. Special treatments are applied to selected areas of the body structure.

### **Ingenuity and teamwork. The essential ingredients of high quality.**

At Ford, striving for high quality is a team effort. This is nowhere more evident than in the hundreds of recommendations for quality improvements submitted every year by more than 1,100 Employee Involvement (EI) groups in 65 Ford plants across America.

In addition to the EI groups, there are "durability-reliability" teams specially trained to carry out extensive quality control programs before production begins, and "quality" teams whose primary responsibility is quality improvement after production gets under way.



With all the technology and resources at work producing quality products, the people at Ford realize that quality is a never-ending preoccupation. This attitude is essential to Ford's total commitment to quality.

# Ride and Handling

## A capable suspension

LTD's modified MacPherson strut front suspension and 4-bar link coil spring rear suspension were designed for solid,

road-holding stability. A front stabilizer bar resists roll and helps the car hug the road during cornering. The 4-bar link arrangement in the rear controls side-to-side and front-to-rear axle motion.



**The advantage of gas-filled shocks and struts**

Gas-filled shock absorbers and struts contribute much to the control and responsiveness of LTD's suspension. By means of a low-pressure charge of nitrogen (1) contained inside, these shocks and struts suppress foaming of the hydraulic fluid (2) due to rapid bumps or similar agitation. This means the ride is smooth under normal circumstances yet firm enough for rough conditions.

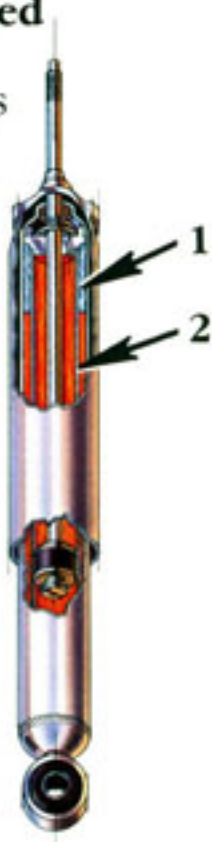

**Power front disc/rear drum brakes**

LTD Sedans and Wagons have a dual service braking system featuring front discs and rear drums. The front discs are Ford's pin slider type designed to reduce brake drag. The one-piece hub and rotor casting is vented for better heat dissipation than non-vented types. LTD brakes are power-assisted for quick stopping action.

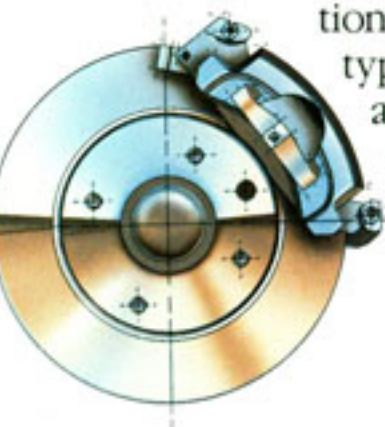

*LTD LX shown with optional pivoting front vent windows and cast aluminum wheels.*

**Special handling system for the LX series**

The unique handling capability of the LX series is the result of special modifications to the Ford LTD suspension combined with Goodyear Eagle GT performance tires. See page 19 for details.

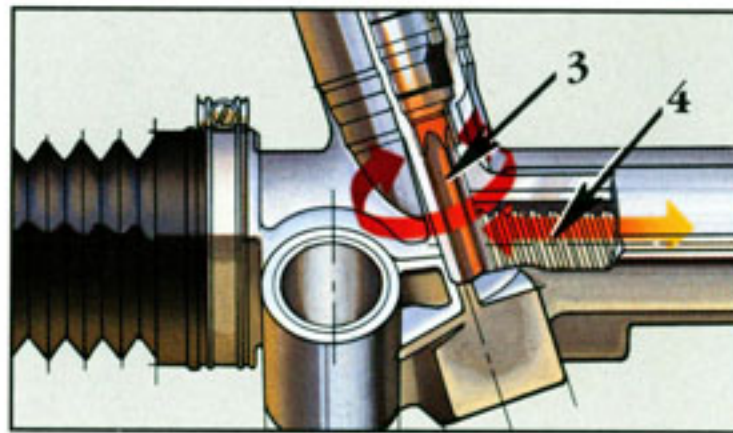

**Rack and pinion steering**

The precision of rack and pinion steering is combined with the convenience of power-assist in LTD's steering system: At the end of the steering column is a "pinion gear" (3) which engages a "rack" (4) of gear teeth linked to the steering arms. The responsiveness and precision of rack and pinion steering are directly related to its simple, low-friction design.

**Air flow as a stabilizing force**

LTD's aerodynamic shape does more than help the engine deliver excellent highway fuel economy.\* The steering and suspension systems benefit as well. Through careful fine-tuning of selected design areas, air flow is directed to reduce front and rear lift for directional stability, cornering agility and reduced wind noise. LTD requires only 6.6 horsepower to push it through the air at 50 mph.

\*See Gas mileage, page 9.

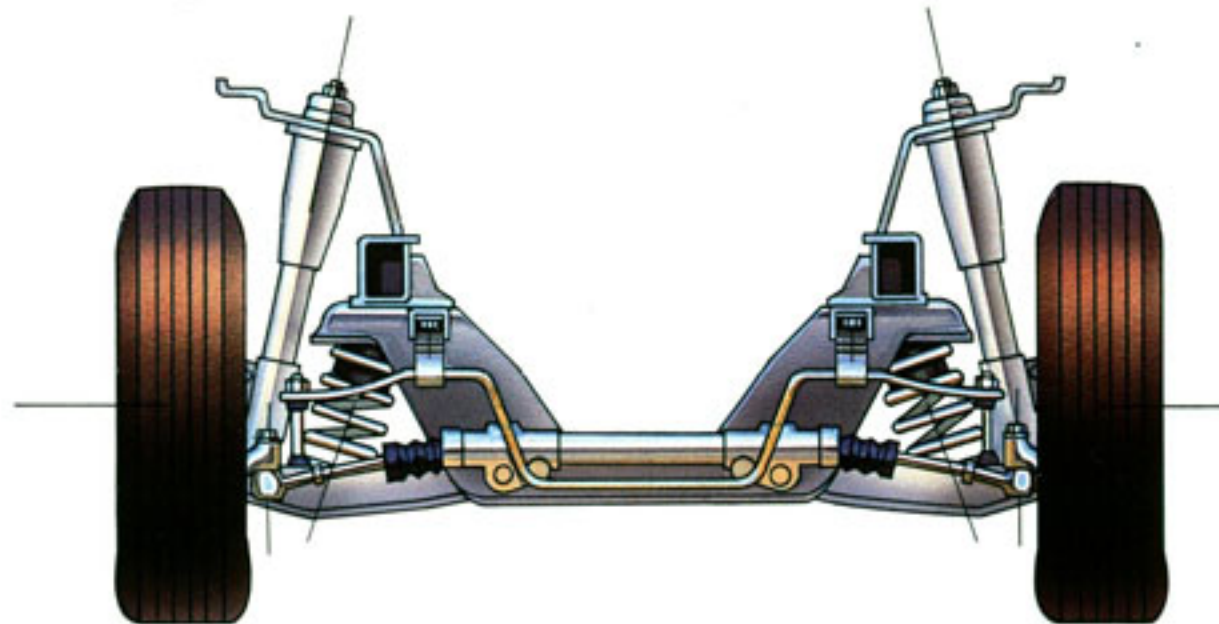

*LTD front suspension system*

# Power and Efficiency

## EEC-IV: one of the world's most advanced automotive computers

LTD's engines benefit from a computer called EEC-IV, a fourth-generation, state-of-the-art, microprocessor-based engine control system capable of process-

ing thousands of operations per second. EEC-IV adjusts the air/fuel mixture and ignition timing for quick cold starts. On the road, it constantly senses what the car is being asked to do, then balances the air/fuel mixture and timing for optimum power, response and efficiency.





### 3.8L V-6 performance

This V-6 powerplant features refinements in combustion chamber intake valve design and high-swirl chambers to help improve fuel economy. The engine also produces excellent torque at part-throttle for good performance off the line. Contributing to smooth operation is a specially designed camshaft which provides an equal 120-degree firing interval among all cylinders.

The 3.8 liter V-6 is standard in LTD Wagons and optional in LTD and LTD Brougham Sedans.

### Standard 4-cylinder efficiency

LTD's standard sedan engine is the overhead cam 2.3 liter 4-cylinder, a responsive, economical powerplant. It's coupled with the SelectShift automatic transmission.

### 5.0 liter High Output EFI V-8 power for LTD LX

Powered by the 5.0 liter High Output V-8 with electronic fuel injection, the Ford LTD LX has all the capability of a high-performance car. See page 19 for more information about 5.0 liter power.

### LTD powerteams

Engine	Transmission	Final Drive Ratio		
		49 States	High Altitude	Calif.
2.3L 4-Cyl.	SelectShift auto.	3.27	3.45	3.27
3.8L V-6	SelectShift auto.	2.73	2.73	2.73
5.0L V-8	Automatic Overdrive	3.27	3.27	3.27

### Gas mileage

1985 EPA mileage estimates were not available at the time this catalog was approved for printing. As soon as EPA figures are released, your Ford Dealer will

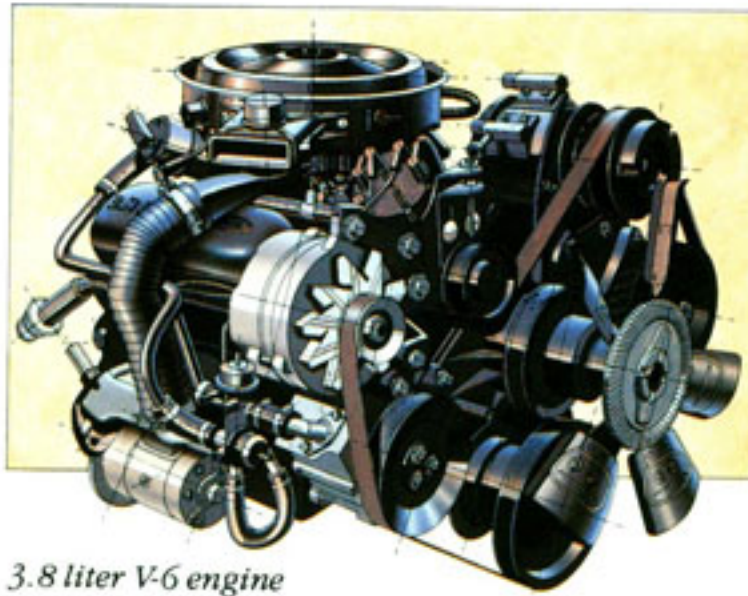

3.8 liter V-6 engine

be among the first to receive this information and will be happy to pass it along to you.

### Automatic Overdrive transmission

The Automatic Overdrive transmission comes standard with the 5.0 liter HO engine in LTD LX. This transmission



automatically shifts into an overdrive fourth gear when the vehicle exceeds 45 mph and the driver eases up on the accelerator pedal. In overdrive, engine speed is reduced by one-third, resulting in improved highway fuel economy and less engine wear.



### LTD aerodynamics contributes to fuel economy

A sloping grille and rear window, sleek decklid, wraparound taillamps, one-piece wraparound bumper sight shields — these are just a few of the elements of LTD's aerodynamic design.

Advanced aerodynamics improves LTD's fuel economy. The lower the coefficient of drag ( $C_D$ ) a vehicle has, the more aerodynamically efficient it is. LTD Sedan's .37  $C_D$  means that less engine power is required to overcome air resistance as the car moves over the road. The engine uses less fuel because it doesn't have to work as hard.

### Traction-Lok axle

Under conditions where one rear driving wheel could spin on ice, snow, sand or mud, the Traction-Lok axle automatically shifts some of the driving force (or torque) to the other wheel to take advantage of its better traction. It's standard in the LX series and available as an option with the other models.

*LTD Brougham 4-Door Sedan shown with optional pivoting front vent windows, right-hand remote-control mirror, rear window defroster, bumper rub strips and styled road wheels.*

# Ford LTD Environment

## LTD ergonomics

The science of ergonomics involves the close relationship of the driver to the car. In LTD, applied ergonomics creates an environment with sensible, convenient placement of seats, controls, instruments and lights. For example, turn signals, windshield wiper/washer controls, headlamp dimmer and flash-to-pass feature are mounted on the steering column at the driver's fingertips.

The split bench front seats have knit

cloth seating surfaces and the seat backs individually recline. They're carefully designed to let driving muscles relax for less fatigue and to hold you behind the wheel through turns. Also available, at no extra cost, is a flight bench front seat (non-reclining) for 6-passenger seating. The center seat position is also a convenient place for small packages. A high-low flow-through ventilation system with a 4-speed heater/ defroster helps maintain a comfortable climate. And, with extensive sound insulation, it's quiet inside as well.



## LTD Wagon

The LTD Wagon combines all the virtues of the LTD Sedan with the convenience of 75.4 cu. ft. of cargo space. And that's a cargo volume index that's unsurpassed by any American-built wagon in its class. Valuable items can be kept securely out of sight in a separate lockable storage compartment. The cargo area is carpeted and lighted, and a warning light on the instrument panel lets the driver know when the liftgate isn't firmly closed.

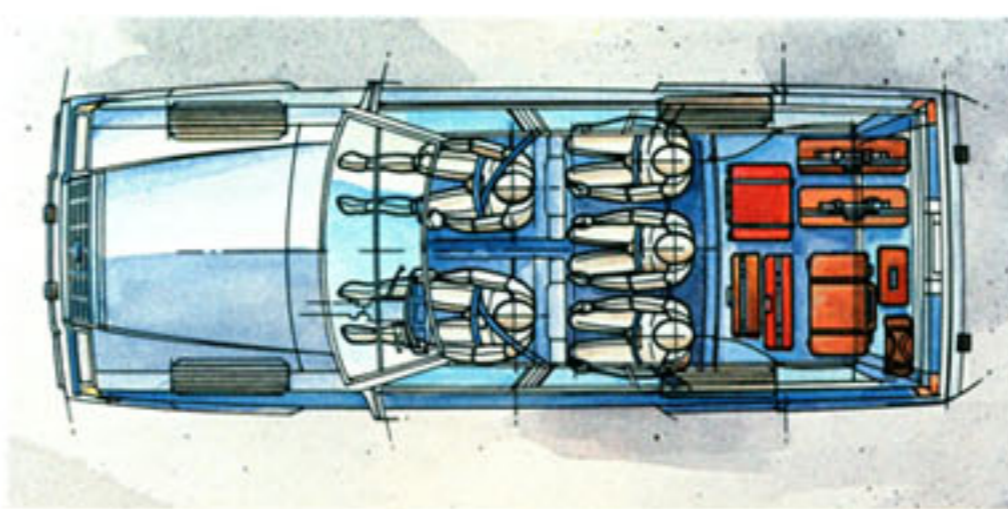

(A): The two-way liftgate option is a practical, convenient wagon feature.

(B): The 3-passenger flight bench front seat, available at no extra cost.

Left: LTD Brougham interior, instrument panel (some equipment shown may be optional); family roominess and spacious cargo area of the LTD Wagon.

# Ford LTD

The aerodynamic LTD 4-Door Sedan offers family-sized comfort and a smooth, quiet ride. Five-passenger seating (6-passenger with optional flight bench

seat) is complemented by a large, deep-well trunk with plenty of luggage space. Gas-filled struts and shock absorbers, power rack and pinion steering and power front disc/rear drum brakes contribute to capable performance on the road.



In LTD Wagon, sedan comfort is combined with a spacious cargo area for optimum utility. Plenty of economical power, too, with the standard 3.8 liter engine and SelectShift automatic transmission.\*

With the Squire Option, woodtone side and liftgate trim is surrounded by contrasting rails for the classic wagon look.

\*See Gas mileage, page 9.

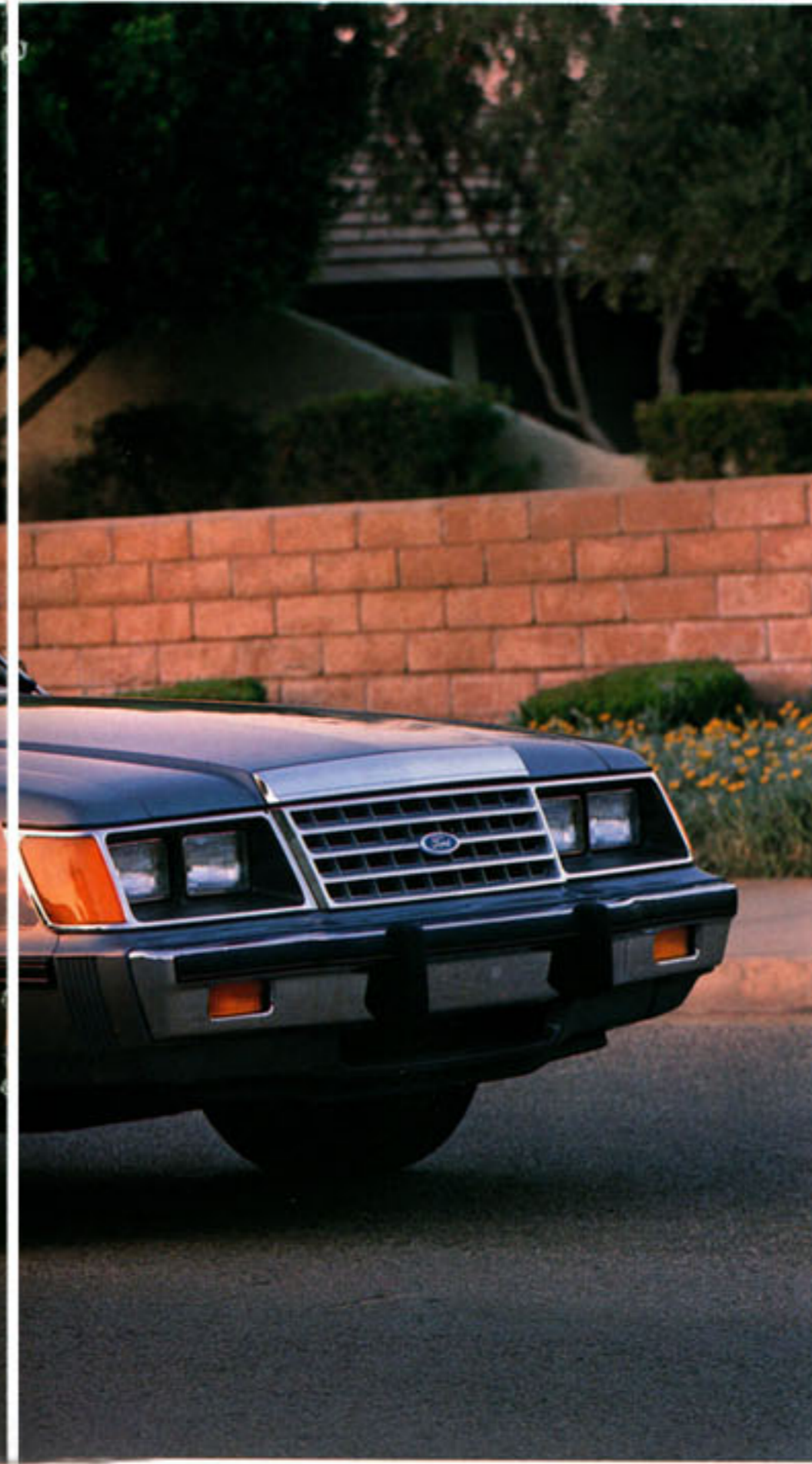

Left: LTD 4-Door Sedan shown with optional illuminated entry system, bumper rub strips, and right-hand remote-control mirror.

# Ford LTD Brougham

The hallmark of the LTD Brougham is the Interior Luxury Group. Seats feature knitted velour cloth seating surfaces and have seat back map pockets (not included

when vinyl trim or flight bench seat is ordered). Door panels have cloth inserts, pull straps, storage bins and carpeting on the lower panel. The luggage compartment is completely carpeted. Thick 16-ounce carpet covers the passenger compartment floor.



Interior lighting includes a dual-beam map light and courtesy lights under the instrument panel. There's also a convenient light under the hood.\* An automatic parking brake release is standard. Electronic items include a digital clock and seat belt reminder chime. There's an illuminated visor mirror for the front passenger as well.

\* These three items are also standard on LX; available as the optional Light Group on LTD Sedan and Wagon.



*Above left: LTD Brougham shown with optional formal roof treatment, pivoting vent windows, styled road wheels, WSW tires, illuminated entry system, right-hand remote-control mirror, rear bumper guards, and bumper rub strips.*

*Left: LTD Brougham shown with optional luxury wheel covers, right-hand remote-control mirror, pivoting vent windows, rear window defroster, rear bumper guards, and bumper rub strips.*

# Ford LTD LX

The impressive performance features of the LTD LX are detailed on the following pages. LX also *looks* the part of a performer, with special charcoal bumper

guards, rub strips, moldings, mirrors and sporty red-orange accents. Dual electric remote-control mirrors are standard. The grille is color-keyed to the body and, in the rear, there's a chrome-plated twin-tip exhaust pipe extension.



*Above left and left: LTD LX shown with optional pivoting vent windows and cast aluminum wheels.*

# Ford LTD LX

Inside the LTD LX is a special place to be. Individually reclining front bucket seats feature charcoal premium-cloth upholstery with oxford grey accents. Both driver and passenger enjoy the comfort of an inflatable lumbar support and, for the

driver, there's a 6-way power seat adjustment. Thick 16-oz. carpet covers the passenger compartment floor, and the luggage compartment is also carpeted. The door trim panels feature cloth inserts and handy storage bins. There's a center console between the seats and a tachometer in the instrument cluster. Additional





convenience items include an electronic digital clock with stopwatch feature, passenger's illuminated visor mirror, dual-beam map light, seat belt reminder chime, engine compartment light and courtesy lights under the instrument panel to illuminate the floor.

### LX under the hood

The standard 5.0 liter High Output V-8 engine features high-technology components such as premium exhaust valves and valve springs, double roller timing chain and special sealing head gaskets.

In addition to the EEC-IV engine control system described on page 9, the engine is equipped with electronic fuel

injection, which has several advantages over conventional carburetors. The major advantage is a more efficient use of fuel.\* This is achieved through precise electronic control of fuel distribution from the fuel injectors. EFI offers improved overall operation, smooth running under way — and easier starting in both hot and cold temperatures.

### Automatic Overdrive transmission

This efficient transmission automatically shifts into an overdrive fourth gear when the vehicle exceeds 45 mph and the driver eases up on the accelerator pedal. In overdrive, engine speed is reduced by one-third, resulting in improved highway fuel economy and less engine wear.

### Traction-Lok axle

A practical LX feature. Under conditions where one rear driving wheel could slip on ice, snow, sand or mud, the Traction-Lok axle automatically shifts some of the driving force (or torque) to the other wheel to take advantage of its better traction.

### The LX handling system

Special modifications to the Ford LTD suspension produce the unique handling capability of the LX. The gas-filled shock absorbers and struts, as well as the front and rear springs, are tuned for tight handling. And for cornering control, there's an increased diameter front stabilizer bar and an added stabilizer bar in the rear.

### LX performance tires

Goodyear Eagle GT P205/70 HR14 tires are mounted on styled road wheels for LTD LX. These tires have an aggressive tread pattern, performance compound rubber and a low-profile design for excellent traction and cornering on dry or wet pavement.



Note: For information on LTD LX steering, brakes, shock absorbers and aerodynamic design, refer to pages 7 and 9.

\*See Gas mileage on page 9.

LX Handling System (Front)

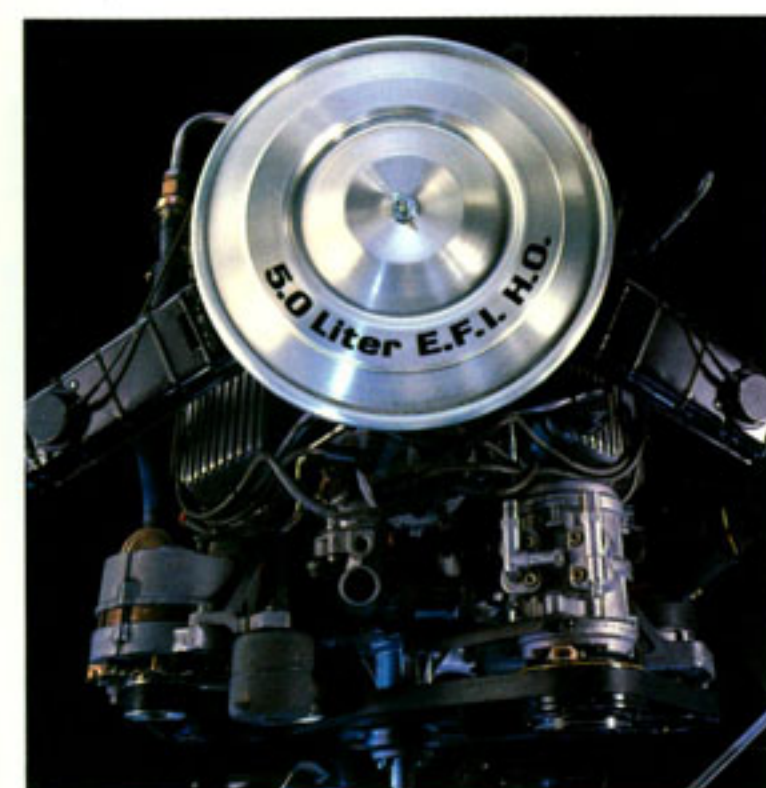
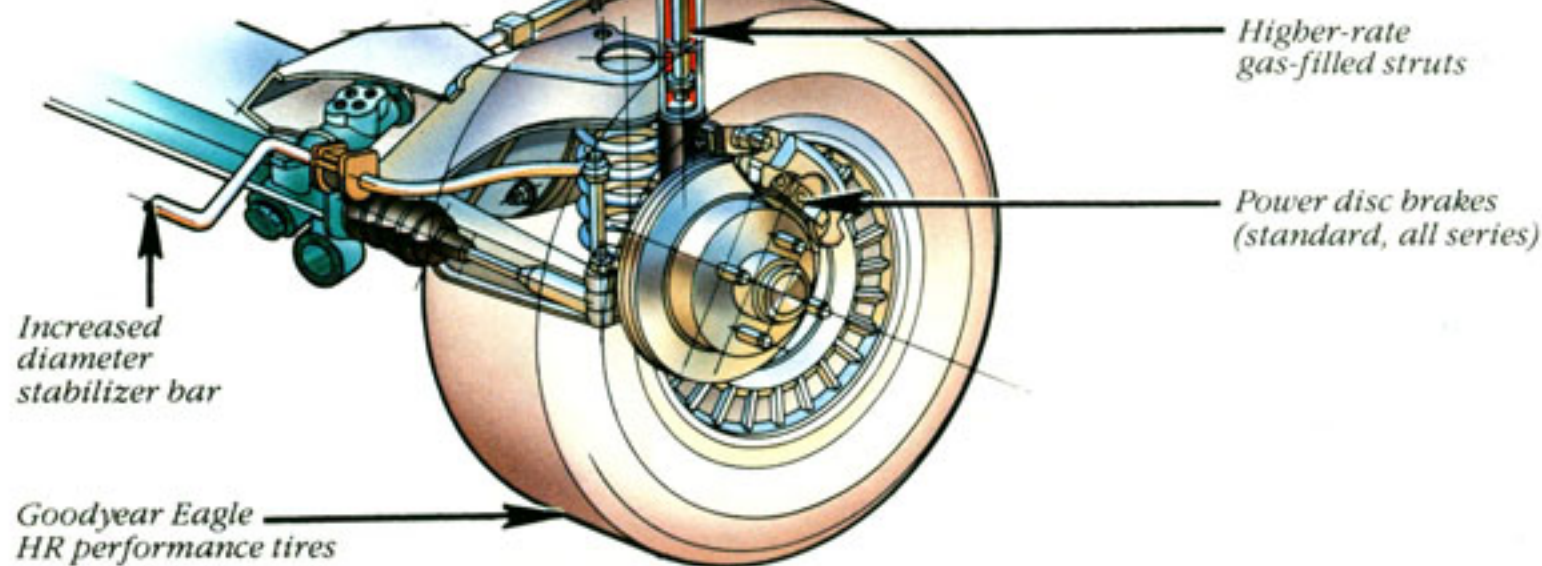

Left: LTD LX interior and instrument panel (some equipment shown may be optional).

# Ford LTD Features and Options

## LTD Rapid-Spec Packages — the best way to buy LTD options.

When you select your new LTD, be sure to ask your Ford Dealer about Rapid-Spec Packages. They benefit you in these two important ways: (1) they simplify the ordering procedure, and (2) they can save you money. Many packages include Value Option Discounts. These can represent savings over the manufacturer's suggested retail price totals of the same options if purchased separately. Your dealer has complete details.

### Illustrated options

(A) Electronic AM/FM stereo search radio with cassette tape player;  
(B) Pivoting front vent windows;  
(C) Speed control; (D) Tripminder® computer. This on-board information center reports average trip speed, the distance covered per gallon of fuel used on the trip, instantaneous fuel economy and total fuel used in either the English or metric system. Other readouts indicate the day and date, time and elapsed trip time and distance; (E) "Tot Guard" (dealer accessory); (F) Luxury wheel covers; (G) Locking wire-style wheel covers; (H) Styled road wheels.



### A word about Ford options

Some of the equipment shown or described throughout the catalog is available at extra cost.



## FORD LTD FEATURES

	LTD Sedan	LTD Brougham	LTD LX	LTD Wagon
<b>ENGINEERING</b>				
2.3 liter IV OHC 4-cyl. engine with EEC-IV Electronic Engine Controls and SelectShift automatic transmission	S	S	NA	NA
3.8 liter EFI V-6 engine with EEC-IV and SelectShift	0	0	NA	S
5.0 liter HO V-8 engine with EFI, EEC-IV and Automatic Overdrive	NA	NA	S	NA
Power front disc/rear drum brakes	S	S	S	S
Power rack and pinion steering	S	S	S	S
Modified MacPherson strut front suspension with front stabilizer bar and gas-filled struts	S	S	S	S
Four-bar link coil spring rear suspension with gas-filled shock absorbers	S	S	S	S
Handling suspension	NA	NA	S	NA
Maintenance-free battery (heavy-duty in LX)	S	S	S	S
Electronic voltage regulator	S	S	S	S
All-season P195/75R 14" steel-belted BSW radials	S	S	NA	S
P205/70HR 14" Goodyear Eagle GT BSW tires	NA	NA	S	NA
Mini spare tire (economy spare on Wagon)	S	S	S	S
"Liftgate Open" warning light	NA	NA	NA	S
<b>EXTERIOR</b>				
Quad rectangular halogen headlamps	S	S	S	S
Front bumper guards	S	S	S	S
Bumper rub strips, rear bumper guards	0	0	S	0
Vinyl-clad bodyside moldings, black with argent stripe	S	S	NA	S
Unique charcoal moldings, red-orange accents	NA	NA	S	NA
Dual accent paint stripes, bodyside and hood (LX bodyside only)	S	S	S	S
Brushed stainless center pillar applique	S	S	NA	S
Bright moldings: windshield, rear window, window frames, drip rail, belts	S	S	NA	S
Chrome-plated twin-tip exhaust pipe extension	NA	NA	S	NA
Left-hand remote-control mirror (dual power with LX)	S	S	S	S
Dual electric remote-control mirrors	0	0	S	0
Deluxe wheel covers	S	S	NA	S
Styled road wheels	0	0	S	0
<b>INTERIOR</b>				
Split bench front seats with recliners	S	S	NA	S
Individual reclining seats with center console	NA	NA	S	NA
6-way power driver's seat	0	0	S	0
Inflatable front seat lumbar supports	NA	NA	S	NA
Standard-level cloth seating surfaces	S	NA	NA	S
Luxury cloth seating surfaces (vary by model)	NA	S	S	0*
Cloth-covered headlining and sun visors	S	S	S	S
Right-hand visor mirror (non-lighted)	S	NA	NA	S
Right-hand illuminated visor mirror	0	S	S	0
Padded vinyl door trim panels with integrated front door storage bins and carpeted lower sections	S	NA	NA	S
Luxury door trim panels with cloth inserts, pull straps, storage bins and carpeted lower sections	NA	S	S	0*
Color-keyed 10-ounce cut-pile carpeting	S	NA	NA	S
16-ounce luxury carpeting	NA	S	S	0*
Color-keyed deluxe belts with comfort regulators	S	S	S	S
Seat belt reminder chime	NA	S	S	0*
Steering column-mounted controls for turn signals, wipers/washer, headlamp dimmers, flash-to-pass	S	S	S	S
Trip odometer	S	S	S	S
Tachometer	NA	NA	S	NA
AM radio with dual front speakers (may be deleted for credit)	S	S	S	S
Carpeted package tray	S	S	S	NA
Locking, illuminated glove box	S	S	S	S
Lighted front ashtray, cigarette lighter	S	S	S	S
Electronic digital clock, Light Group**	0	S	S	0
Rear door courtesy lamp switches	S	S	S	S
Automatic parking brake release	NA	S	NA	0*
Fold-down rear seat with carpeting on seat back	NA	NA	NA	S
Carpeted cargo area	NA	NA	NA	S
Lockable storage compartment in left quarter panel	NA	NA	NA	S
Luggage compartment carpet with carpeted taillamp liner boards	S	NA	NA	NA
Luxury luggage compartment trim, including carpeted spare tire cover and carpeted side and taillamp liner boards	NA	S	S	NA
Luggage compartment/cargo area light	S	S	S	S

S = Standard O = Optional  
 \*Available with Interior Luxury Group only.  
 \*\*See LTD Options for contents.

## FORD LTD OPTIONS

	LTD Sedan	LTD Brougham	LTD LX	LTD Wagon
<b>ENTERTAINMENT SYSTEMS</b>				
AM/FM stereo radio	0	0	0	0
AM/FM stereo radio with cassette player	0	0	0	0
Electronic AM/FM stereo search radio with cassette	0	0	0	0
Premium sound system (stereo radios only)	0	0	0	0
<b>APPEARANCE</b>				
Squire Option (see page 13)	NA	NA	NA	0
Two-Tone paint with tape stripes (1)	0	0	NA	0
Full vinyl roof	0	0	NA	NA
Formal roof treatment (see page 15)	0	0	NA	NA
<b>ASSISTS/ELECTRONIC DRIVING AIDS</b>				
Autolamp system	0	0	0	0
Electronic digital clock	0	S	S	0
Diagnostic warning lights	0	0	NA	0
Tripfinder® computer (see "D" page 20)	0	0	0	0
<b>COMFORT AND CONVENIENCE (Interior)</b>				
Air conditioning, automatic or manual controls	0	0	0	0
Flight bench seat (2)	0	0	NA	0
Tinted glass, complete	0	0	0	0
Interior Luxury Group (see page 14)	NA	S	NA	0
Light Group (3)	0	S	S	0
Dual illuminated visor mirrors	0	0	0	0
Speed control	0	0	0	0
Leather-wrapped steering wheel	0	0	0	0
Tilt steering wheel	0	0	0	0
<b>COMFORT AND CONVENIENCE (Exterior)</b>				
Cornering lamps	0	0	0	0
Rear window defroster	0	0	0	0
Illuminated entry system	0	0	0	0
Two-way liftgate	NA	NA	NA	0
Luggage rack	NA	NA	NA	0
Dual electric remote-control mirrors	0	0	S	0
RH remote-control convex mirror	0	0	NA	0
Pivoting front vent windows	0	0	0	0
Interval windshield wipers	0	0	0	0
Rear window wiper/washer	NA	NA	NA	0
<b>INTERIOR TRIM</b>				
All-vinyl seats	0	0	NA	0
<b>PROTECTION</b>				
Lower bodyside protection	0	0	0	0
Black vinyl-clad rocker panel moldings (1)	0	0	NA	0
Front license plate bracket (no-cost option)	0	0	0	0
Rear bumper guards	0	0	S	0
Bumper rub strips	0	0	S	0
Color-keyed front carpet floor mats	0	0	0	0
<b>POWER ASSISTS</b>				
Power Lock Group (4)	0	0	0	0
6-way power driver's seat	0	0	S	0
Dual 6-way power seats	0	0	NA	0
Power side windows	0	0	0	0
<b>TIRES</b>				
P195/75R 14 white sidewall	0	0	NA	0
P195/75R 14 white sidewall puncture-sealant	0	0	NA	0
P205/70R 14 tires, WSW	0	0	NA	0
<b>WHEELS/WHEEL COVERS</b>				
Luxury wheel covers	0	0	NA	0
Locking wire-style wheel covers	0	0	NA	0
Styled road wheels	0	0	S	0
Cast aluminum wheels	NA	NA	0	NA
<b>PERFORMANCE</b>				
3.8 liter V-6 engine	0	0	NA	0
Traction-Lok axle	0	0	S	0
Heavy-duty maintenance-free battery	0	0	S	0
Extended range fuel tank (20-gallon usable capacity)	0	0	0	NA
Engine block immersion heater	0	0	0	0
California Emissions System	0	0	0	0
High Altitude Emissions System	0	0	0	(5)

(1) Not available with Squire Option.  
 (2) No-cost option. Non-reclining.  
 (3) Includes engine compartment light, dual-beam map light and two courtesy lights under the instrument panel.  
 (4) Includes power door locks on all models, power decklid release on sedans, and remote-locking fuel filler door which includes a manual emergency feature.  
 (5) Wagon is available in high altitude areas, but requires no special equipment.

## COLORS AND TRIMS



### Interior Trim Colors

	Charcoal*	Canyon Red	Regatta Blue	Clove Brown	Sand Beige	Exterior Colors
•	•					Medium Charcoal Metallic
•	•	•				Black
•	•	•	•			Silver Metallic
•	•			•		Medium Canyon Red Metallic
•	•			•		Midnight Canyon Red Metallic
•	•	•		•		Midnight Blue Metallic
•		•		•		Light Regatta Blue Metallic
			•	•		Dark Slate Metallic
			•	•		Dark Clove Brown Metallic
•			•	•		Sand Beige
			•	•		Medium Sand Beige
•	•	•	•	•		Oxford White

**NOTE:** Color and trim availability for sedans with optional formal roof treatment differs slightly. See your dealer for details.

\*Not available on wagons.  
 Some of these paint and trim colors are shown in this catalog. On the printed page, of course, colors are at best only representative of the originals. Your Ford Dealer can show you actual samples of the paint colors and trim materials presented above as well as Two-Tone paint with tape stripe combinations.

# Safety Features

## A commitment to safety

Safety, like quality, begins as an attitude, a way of thinking that's fundamental in shaping a vehicle's structure and components from the drawing board to assembly.

## Occupant safety

Ford commits enormous resources every year to the development and testing of all car lines and their occupant protection features.

Body structures are carefully designed from the start with passenger safety as a primary concern. After they are validated for theoretical soundness, structures are assembled into prototype vehicles and subjected to exhaustive crash testing.

## Operating safety

This term applies to a vehicle's ability, with the aid of the driver, to avoid an accident.

Ford cars are engineered to do their part — provide suspension and steering systems designed for control, as well as a brake system designed to provide fast stopping action and fade resistance.

Of course, it's up to the driver to make the best use of the vehicle's accident-avoidance equipment. This involves driving defensively, reacting in time and such seemingly small things as properly regulating the ventilation system (to help the driver stay alert).

## 5-mile-an-hour bumpers

Bumpers on Ford LTD are designed to protect lamps, cooling system, exhaust and other body components in the event of a minor impact. While some manufacturers have replaced the 5-mile-an-hour bumper system with a 2½-mile-an-hour system, Ford offers you the protection of 5-mile-an-hour bumpers front and rear.

## Get it together — buckle up.

Ford Motor Company strongly encourages all passengers to use their safety belts.

In all Ford cars, outboard front seat lap and shoulder belts have automatic retractors and comfort regulators. Outboard rear seat positions also have lap belts with retractors.

Ford urges the use of child and infant restraints, even in states where they are not required by law. Ford's easy-to-install Tot-Guard (for children 20 to 50 pounds) and Infant Carrier (for children up to 20 pounds) are available at all Ford Dealers. If a child



restraint requires a top-tether, Ford cars provide for attachment of an anchor at each rear outboard seating position.

## Ford LTD Lifeguard Design Safety Features

### Vehicle operation

- Safety rim wheels and load-rated tires
- Split service hydraulic brake system with warning light
- Corrosion-resistant brake lines
- Flash-to-pass headlamps
- Turn indicator lever with lane-changing signal feature
- Hazard warning flasher
- Backup lights
- Side marker lights
- Parking lights coupled with headlamps
- Two-speed windshield wipers
- Windshield washers
- Outside rearview mirror, driver's side
- Glare-reduced instrument panel, windshield wiper arms and windshield pillars
- Uniform transmission shift quadrant with safety starting switch
- Continuously variable control illumination intensity (instrument cluster lighting)
- Safety hood latch system
- Function-rated windshield defroster system

### Occupant protection

- Safety-designed front end structure
- Safety-designed roof structure
- Steel guard rails in side doors
- Double yoke safety door latches and safety hinges
- Integral lap and shoulder belts with automatic retractors for front outboard occupants
- Positive seat belt fastening reminder warning light and buzzer or chime for the driver's seat
- Lap belts for center front (with optional 3-passenger front seat) and all rear seating positions with retractors for rear outboard occupants
- Energy-absorbing steering column and steering wheel
- Energy-absorbing armrests and door handles
- Energy-absorbing instrument panel with padding for right and center (with optional three-passenger front seat) front passengers
- Energy-absorbing sun visors
- Energy-absorbing front seat back tops
- Self-locking front seat back latches
- Head restraints for front outboard occupants
- Safety glove box latch
- Inside yieldaway rearview mirror
- Impact-absorbing laminated safety glass windshield
- Flame resistant interior materials
- Safety-designed coat hooks
- Safety-designed radio control knobs and push buttons

### Anti-theft

- Locking steering column with key warning buzzer (or chime) reminder (with "Park" interlock for key release)
- Visible vehicle identification number
- Single key with anti-theft design for door entry and ignition

### Damage resistance

- Impact resistant front and rear bumper systems

# Owner Information

## Measurements

	Sedan	Wagon
Wheelbase	105.6"	105.6"
Length	196.5"	196.5"
Height	53.8"	54.4"
Width	71.0"	71.0"
Front tread	56.6"	56.6"
Rear tread	57.0"	57.0"
Cargo Volume Index (cu. ft.)	15.1	75.4*
Fuel capacity (gal.)	16.0**	16.0#
Curb weight (lb.)	3,000+	3,107+
Passengers	5++	5++

\*41.6 cu. ft. with rear seat up. \*\*Optional 20-gallon extended range fuel tank available. 15.4-gal. capacity standard with electronic fuel injection. #15.3-gal. capacity with electronic fuel injection. +With 3.8 liter V-6 engine. LX Sedan with 5.0 liter V-8 is 3,303 lb. ++Six passengers with optional flight bench front seat (not available in LX).



As part of Ford Motor Company's commitment to your total satisfaction, participating Ford Dealers offer the Free Lifetime Service Guarantee. They stand behind their work, in writing, for as long as you own your car. This guarantee covers virtually every repair you pay for after your new vehicle warranty expires. Now when you pay for a covered repair once, you never have to pay for the same repair again. Ever. The dealer who did the work will fix it free. Free parts. Free labor.

While it doesn't cover routine maintenance parts, belts, hoses, sheet metal or upholstery, this limited warranty does cover thousands of parts in normal use.

No other car company's dealers, foreign or domestic, offer this kind of security. Nobody.

See your participating Ford Dealer for details.



Ford Motor Company's optional Extended Service Plan covers major components on new Ford cars and light trucks for longer than the vehicle's basic warranty. The cost is so moderate for the protection you get that it could pay for itself the first time you need it. Your Ford Dealer will be happy to detail the plan for you.

Available on all cars and most light trucks, it is honored by more than 6,100 Ford and Lincoln-Mercury dealers nationwide and in Canada.



**QUALITY REPLACEMENT PARTS FROM FORD**

Genuine Ford and Motorcraft original equipment replacement parts are precision engineered and manufactured to Ford specifications to deliver top-level performance in all Ford-built cars and trucks. The Ford and Motorcraft brand names are your best assurance of quality and long-term satisfaction because these replacement parts meet the same high standards as those installed in production, and at Ford, "Quality is Job 1."

### Scheduled maintenance

Ford wants to reduce the frequency and cost of scheduled maintenance on its cars to an absolute minimum. Here are some examples of scheduled maintenance intervals for the 1985 Ford LTD. For complete maintenance recommendations, refer to the LTD Owner Guide.

Engine oil change	.....	each 7,500 miles
Spark plug change	.....	each 30,000 miles
Air filter replacement	.....	each 30,000 miles
Engine coolant replacement	.....	each 52,000 miles or 3 years (30,000 miles or 3 years with 3.8L V-6)

### The commitment to quality by Ford and its dealers can save you money on repairs, too.

In addition to the Lifetime Service Guarantee, the Extended Service Plan and Ford and Motorcraft original equipment parts already described, Ford and Ford Dealers are working in other ways to save you money on repairs and help ensure your satisfaction.

### Nationwide dealer network ready to assist you

Should your Ford car or truck need repair while you're traveling or away from home, the nearest servicing dealer can be located simply by calling one of the toll-free numbers listed under "Ford-paid repair programs."

### Specialized tools and equipment

The latest in diagnostic and service equipment designed especially for use in the repair of Ford Motor Company products is available. This equipment helps the technician make the repair properly so you won't have to come back a second time.

### Continued service technician training

Dealership technicians are continuously updated on the latest techniques and procedures to help them keep your Ford car or truck running at its best.

### Ford-paid repair programs after the warranty period

Sometimes Ford offers adjustment programs to pay all or part of the cost of certain repairs. These programs are intended to assist owners and are in addition to the warranty or to required recalls. Ask Ford or your dealer about such programs relating to your Ford or Lincoln-Mercury vehicle.

To get copies of any adjustment program for your vehicle or the vehicle of interest to you: Call Ford toll-free at 1-800-241-3673. Alaska/Hawaii call 1-800-241-3711 and in Georgia call 1-800-282-0959.

Or write Ford at:

Ford Customer Information System  
Post Office Box 95427  
Atlanta, Georgia 30347

We'll need your name and address; year, make and model vehicle, as well as engine size; and whether you have a manual or automatic transmission.

### Technical service bulletins

All vehicles need repairs during their lifetime. Sometimes Ford issues technical service bulletins (TSBs) and easy-to-read explanations describing unusual engine or transmission conditions which may lead to costly repairs, the recommended repairs, and new repair procedures. Often a repair now can prevent a more serious repair later. Ask Ford or your dealer for any such TSBs and explanations relating to your Ford or Lincoln-Mercury vehicle.

To get copies of these technical service bulletins and explanations for your vehicle or the vehicle of interest to you: Call Ford toll-free at 1-800-241-3673. Alaska/Hawaii call 1-800-241-3711 and in Georgia call 1-800-282-0959.

Or write Ford at:

Ford Customer Information System  
Post Office Box 95427  
Atlanta, Georgia 30347

We'll need your name and address; year, make and model vehicle, as well as engine size; and whether you have a manual or automatic transmission.

### Options availability

Options shown or described in this catalog are available at extra cost and may be offered only in combination with other options or subject to additional ordering requirements or limitations. Your Ford Dealer has the latest information.

### Product changes

Ford Division reserves the right to change product specifications at any time without incurring obligations.

### "Ask your Ford Dealer"

Following publication of this catalog, certain changes in standard equipment, options, prices and the like, or product delays, may have occurred which would not be included in these pages. Your Ford Dealer is your best source for up-to-date information.

**Have you driven  
a Ford...lately?**



**FORD LTD**

