

SEE PAGE 8

SERIES F-100

MAX. G.V.W.—5,000 LBS.

For the exciting
story of
Ford's New
**SHORT
STROKE
ENGINES**



The **Money-Makers!**

FORD TRUCKS for '55 with ***TRIPLE ECONOMY***

Now! **MAKE EVERY RUN AN ECONOMY RUN!**

Make money...save money with FORD TRUCK TRIPLE ECONOMY!

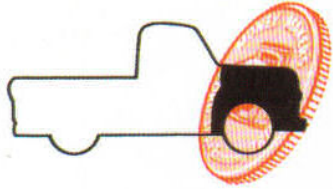

MONEY-MAKING POWER

that saves gas!

Only Ford gives you the gas-saving efficiency of modern, short-stroke engine design in both V-8 and Six. Pistons in the 118-h.p. *Cost Clipper* Six and the 132-h.p. *Power King* V-8 travel a shorter distance, and at slower speed . . . reducing friction, liberating more usable hauling power. With new durability features, Ford Truck engines are engineered to last longer, earn longer!

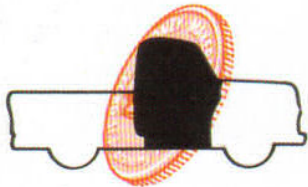

MONEY-MAKING CONVENIENCE

that saves work!

Ford *Driverized* Cabs, both Standard and Custom, have the greatest array of driving conveniences ever offered in a truck cab . . . which, combined with new comfort features, cut fatigue and conserve the driver's time and energy. Never before has a truck cab given the driver so great an incentive to do his best work!

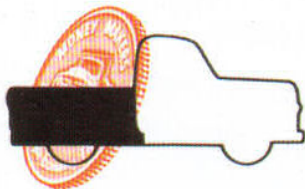

MONEY-MAKING CAPACITIES

that save trips!

Ford Truck chassis give you top load-carrying ability to fit your job. There's extra strength in every component part without excess weight. Over-all chassis weights are low . . . resulting in big payload capacities. Large payload capacities mean fewer trips . . . lower cost per trip . . . greater economy!

and...



Here's in

Take a look at everything a new Ford Pickup offers . . . to handle your job easily, quickly, and at rock bottom cost!

In power—Ford offers the only choice of modern short-stroke engines, V-8 or Six, in any Pickup! Ford's *low-friction* engines with higher compression—the 118-h.p. *Cost Clipper* Six and the 132-h.p. *Power King* V-8—deliver their high usable power with gas-saving efficiency. Short-stroke design means less wear on moving parts, greatly prolonged piston ring life, *longer-lasting engines*.

In comfort—there's no cab for driving ease and convenience like Ford's *Driverized* Cab! Easier controls, such as *Fordomatic Drive**, *Power Brakes**, save work for the driver, make for greater safety.

In capacity—Ford Pickups have a big, 45 cu. ft. loadspace and top payload capacity, one of the largest in the half-ton field. With a 5-transmission choice and wide selection of other equipment options, you can match a new Ford Pickup exactly to your job.

**Extra Cost.*

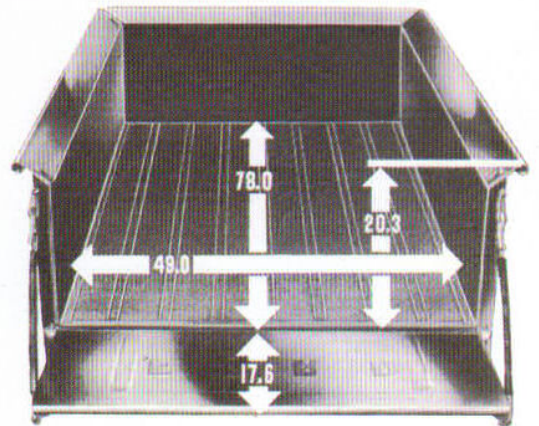

A top payloader in its class, the new Ford F-100 has a big, 45 cubic foot pickup box. Riveted and bolted construction gives extra strength and rigidity. Smooth, heavy-gage steel side panels give unobstructed loadspace full length of body. High, 20-inch side panels with slanting, roll-top flare design, facilitate cargo handling and provide safer, sturdier load protection. Strong, rigid side panels can easily be replaced if necessary. The seasoned wood floorboards are interlocked with durable steel skid strips extending the full length of the floor, to give the utmost protection in severe service.

"Reproduced under license agreement
with Ford Motor Company."
License # 5001 3-1-94

versatility unmatched the 1/2-ton field!

New
F-100
6½-ft.
PICKUP

Payload (equipment, etc.)
up to 1,718 lbs.
Wheelbase: 110 in.

Power Braking!
Fordomatic Drive!
Side-mounted tire carrier!
I-REST tinted safety glass!
Available at modest extra cost.

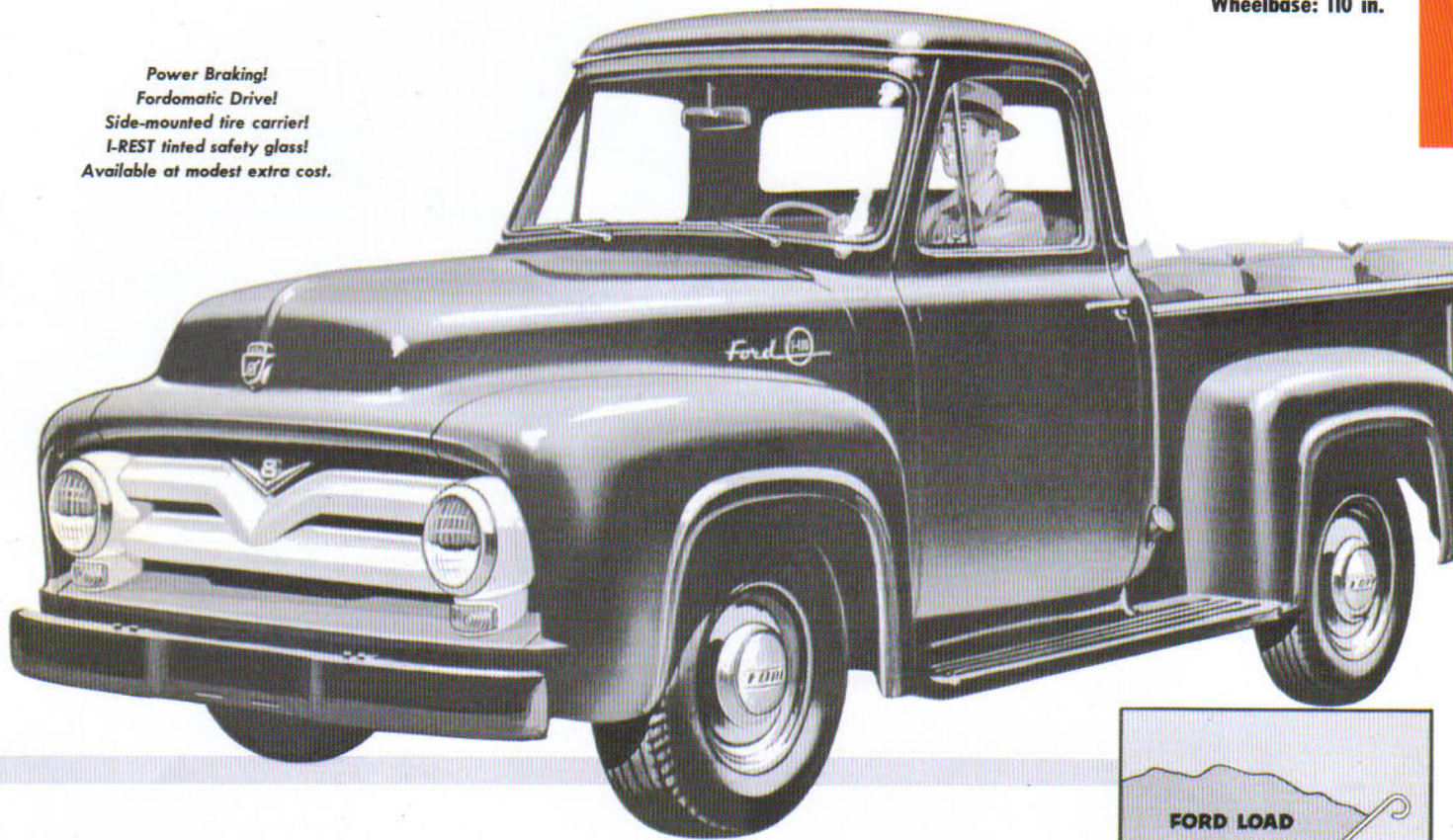

**FOUR
STAKE POCKETS**

in corner posts permit mounting of uprights for special tops.

**HEAVY-GAGE
STEEL SIDE PANELS**

have smooth surface, no wheel-house or other obstructions to snag loads. Front and side panels are the same height.

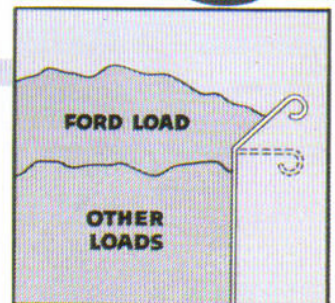

DURABLE TAILGATE

has rolled-top edge for added strength. Forms rigid level platform, when locked horizontally. Rubber cushioned strips on sides eliminate rattles when closed.

Flanged sideboards have slanting design with rolled edge for greater strength, permit more load protection than other-make trucks with flat-top sideboards.

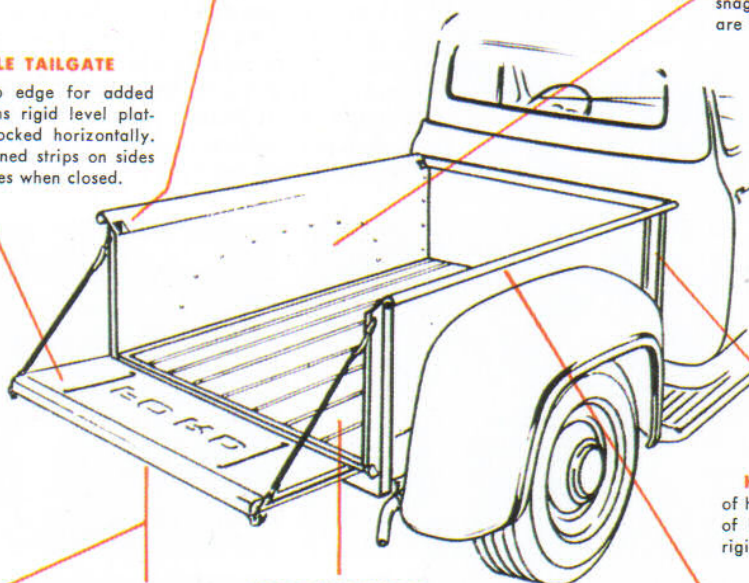

**LOW FLOOR-TO-GROUND
HEIGHT**

just over 2 feet, facilitates easier loading and unloading.

**SEASONED WOOD
FLOORBOARDS**

protected by steel skid strips for long service. Level with lowered tailgate, skid strips facilitate sliding heavy items easily along floor.

HUSKY CORNER POSTS

of heavy steel, welded to outside of body for extra strength and rigidity.

ROLLED EDGES

of flare boards reinforce side panels, aid loading and unloading.

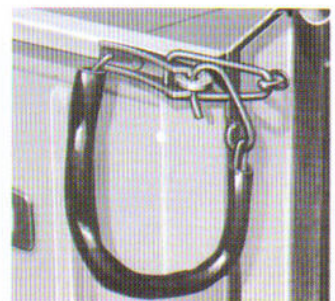

Dependability-proved toggle-type latches keep tailgate tightly clamped to body sides for effective seal. Forged steel chains support tailgate when opened and under heavy load.

**New
F-100
8-ft.
PANEL**

Half-ton Panel cuts delivery

**Payload (equipment, etc.)
up to 1,553 lbs.
Wheelbase: 110 in.**

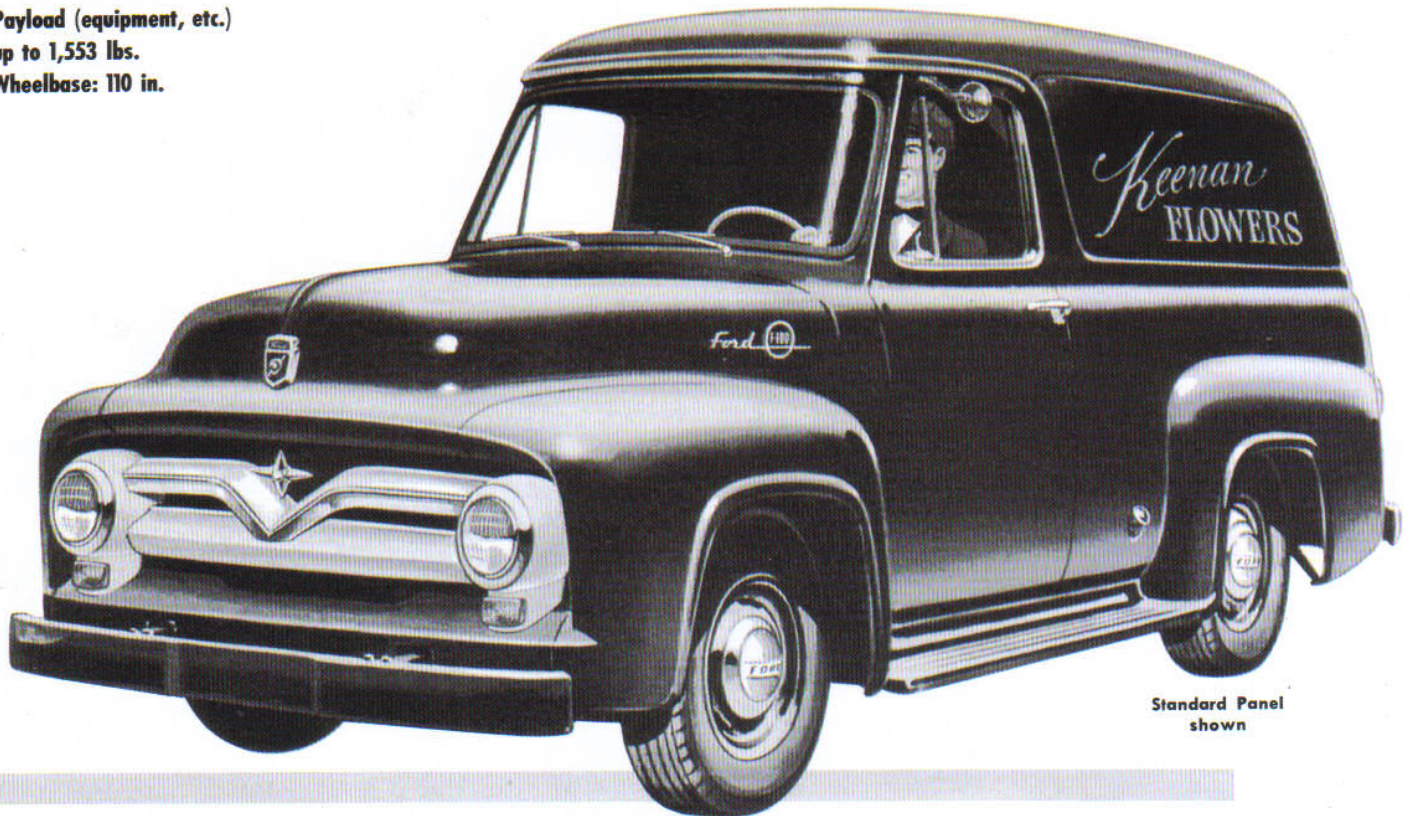

Standard Panel shown

**Power Braking!
Fordomatic Drive!
I-REST tinted safety glass!**
Available at modest extra cost.

Your stop-go delivery work can be faster and more economical . . . with the power, convenience and loadspace features you'll find in Ford's F-100 Panels, both Standard and Custom.

Choose from two, modern, overhead-valve, short-stroke, gas-saving engines . . . the 118-h.p. *Cost Clipper* Six and the 132-h.p. *Power King* V-8.

At the wheel, the driver has the full-view advantage of a big, one-piece windshield, large side windows . . . the work-saving advantages of easy-handling controls, the comfort of free-breathing woven plastic seat upholstery and plenty of room. Loads stow easily through big, wide-opening rear doors. Ford Panels take up to 1,553 lbs. of payload! Choose from 5 transmissions, including Overdrive and *Fordomatic*. Vacuum-boosted power braking available, too!

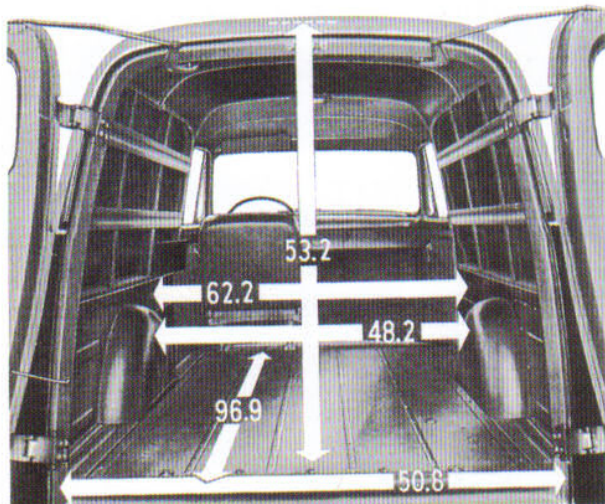

Big, 155.8 cu. ft. cargo space is designed for convenient handling of big, bulky items. Reinforced, welded steel body measures 53.2 in. high, 62.3 in. wide, 139.5 in. long (along driver's seat) for loads 11½ ft. long! Sides have steel paneling from floor to top of wheelhouse, for extra load protection.

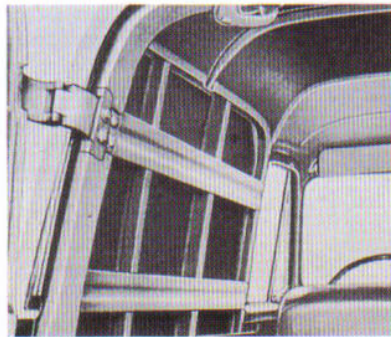

Strong, steel horizontal slats, two on each side, team up with vertical steel ribs to give stronger body reinforcement, added load protection. Slats are smooth-surfaced, to prevent snagging when loading or unloading.

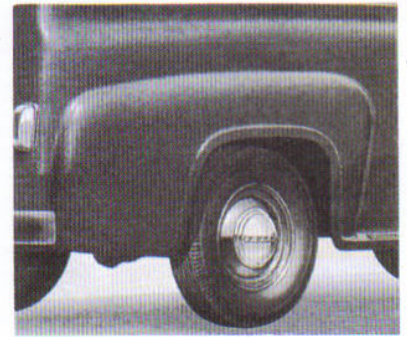

Integral rear fenders and side panels are welded together in one piece for extra strength and long life. No seams to catch water, and eventually rust out. Two tail lights standard. Heavy-gauge steel channel rear bumper (std.).

time and costs to the bone!

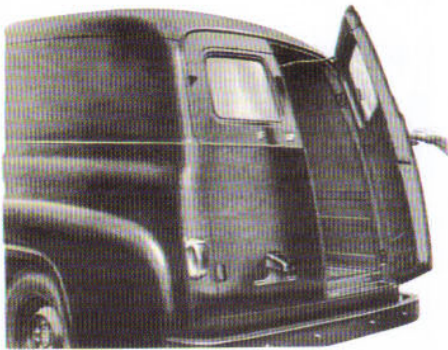

Heavy steel doors open fully, or hold firmly at 90° open, for easier loading of cargo. Doors are of heavy-gage steel construction with sturdy double door latches to hold doors in permanent alignment.

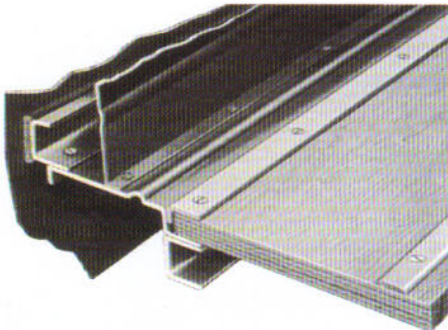

Dust-tight, fume-tight load protection is provided by solid plywood floor, impregnated for longer life, protected by steel skid strips. Body sealed tight at joints of wheelhouse strips and side panels.



Spacious advertising area has 6 ft. x 1 3/4 ft. of unobstructed side panel space for displaying firm name or advertising messages. The distinctive Ford Panel Truck is in itself an attractive advertisement for your business.

CUSTOM PANEL, the last word in panels, has more features you want and need than you'll find in any other make. And all at only slightly extra cost!

In Ford's Custom Panel, you get all the fine features of the Standard model . . . plus 15 "customized" extras well worth their small added cost. Extras include exterior trim features for a still richer, smarter appearance . . . functional features that make the job easier for the driver and give added load protection. The Custom Panel has:

INTERIOR

1. Color-keyed two-tone driver's seat upholstery.
2. Foam-rubber padding over standard non-sag seat springs in driver's seat.
3. Durable harmonizing door panel trim.
4. Headlining backed by 1 in. glass-wool insulation, full length of roof panel.
5. Sound deadener on driver's compartment floor (standard on doors).
6. Heavy masonite lining on panel sides.

7. Grip-type arm rest on left front door (driver's side).

8. Large dome light with manual switch.

9. Two adjustable sun visors.

10. Illuminated cigar lighter.

EXTERIOR

11. Custom identification plate.

12. Bright metal lead edge on upper grille bar.

13. Bright metal Air Wing frames.

14. Bright metal drip molding cap.

15. Matched key locks on all doors.



New

F-100

6½-ft.

PLATFORM-STAKE

Payload (equipment, etc.)

up to 1,633 lbs.

Wheelbase: 110 in.

Money-making master of light, bulky loads!

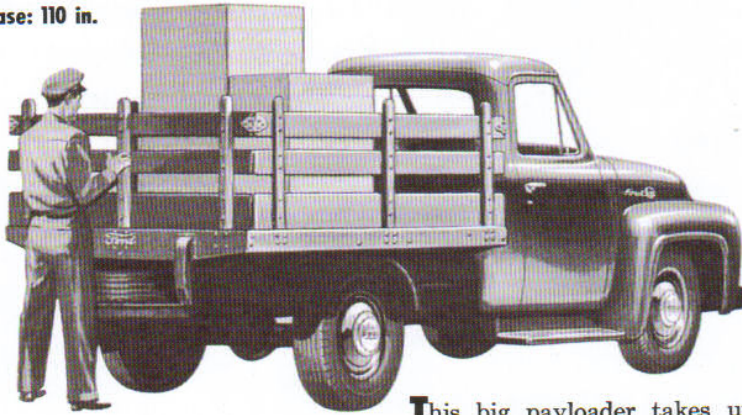

Ford offers this 6½-ft. stake body factory-installed on the F-100 chassis-cab for low first cost!

This big payloader takes up to 1,633 lbs. of cargo (including equipment, etc.). Cargo can be handled quickly, with minimum effort, from side or rear.

With two higher-powered, short-stroke engines to choose from . . . V-8 or Six . . . and any one of 5 transmissions, including *Fordomatic* and Overdrive, Power Braking, and many other equipment options at extra cost . . . you can "tailor" your Ford Platform-Stake exactly as you want it.

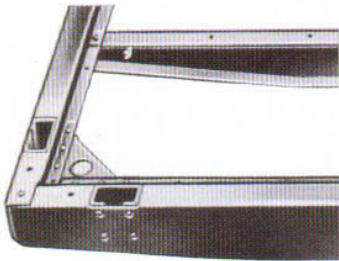

Sturdy, bridge-type frame

has heavy-gage steel side rails riveted to steel cross girders for extra-strong platform support. Heavy steel angle brackets are riveted to girders, bolted to sills for greater durability. All corners are reinforced with large steel gusset plates.

Strong, spacious platform

is 6½ ft. long, 5½ ft. wide! Stake and rack boards are straight-grained, seasoned wood. Stake racks are held firmly at the top by strong, interlocking steel plates. Stake pockets are flush with floor for unobstructed open platform use. Heavy steel rub rail and steel caps on body ends protect platform.

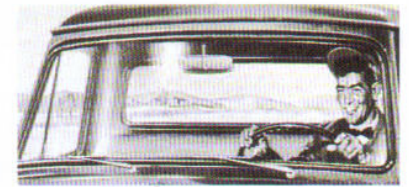
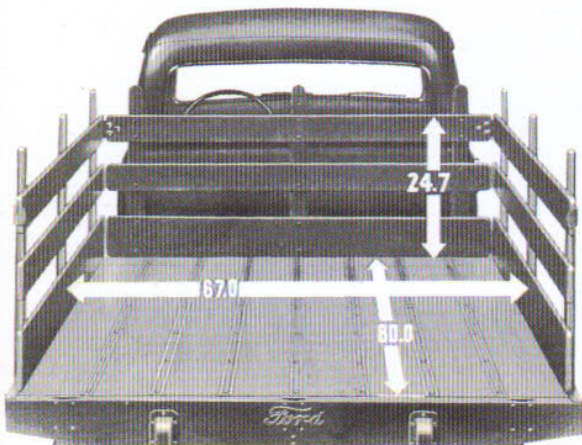

Big, curved windshield with swept-back pillars gives driver visibility unlimited. Side windows are arm-rest deep. Rear window, over 4 ft. wide, is standard on all *Driverized Cabs*. I-REST tinted safety glass available at extra cost.

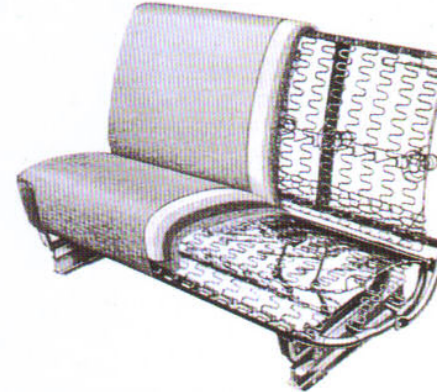

Big, 3-man seat has full-breathing woven plastic upholstery that looks better, cleans easier, lasts longer. Standard Cab seat (illustrated) has non-sag springs, exclusive *shock snubbers*. Seat and seat back adjust independently.

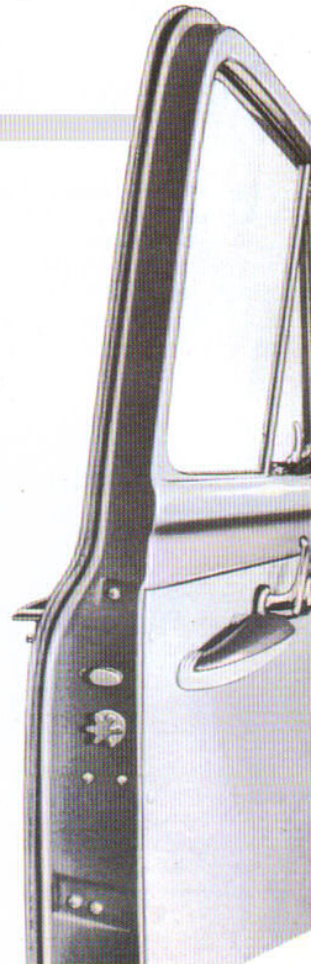

Famed Ford DRIVERIZED Cabs

bring comfort you wouldn't think possible
in a truck . . . plus features that save time
. . . make the driver's job easier!

Every comfort and convenience a driver could want are provided in Ford's 3-man *Driverized* Cab! A big, sweeping, one-piece curved windshield, deep side windows, and a rear window that's almost cab-wide, give practically full range, all-around vision for safer, easier driving. The seat takes three *big* men comfortably. Upholstery is of *woven* plastic that "breathes," keeps cooler in hot weather, lasts longer. Doors swing wide for easy entrance and exit. Controls are conveniently located. There's room aplenty in every direction. These and other features save the driver's time . . . make his work easier. Never before has a truck cab given the driver so great an incentive to do his best work!

Standard cab includes double-steel safety-type doors with wide-swing, adjustable gooseneck hinges • Modern push-button door handles with rotor type latches, with safety catch • Overlapping dual windshield wipers • Large Air Wing vents and full-scoop cowl ventilator • Left-hand sun visor, rear view mirror, ash receptacle and dispatch box • Key lock on right door.

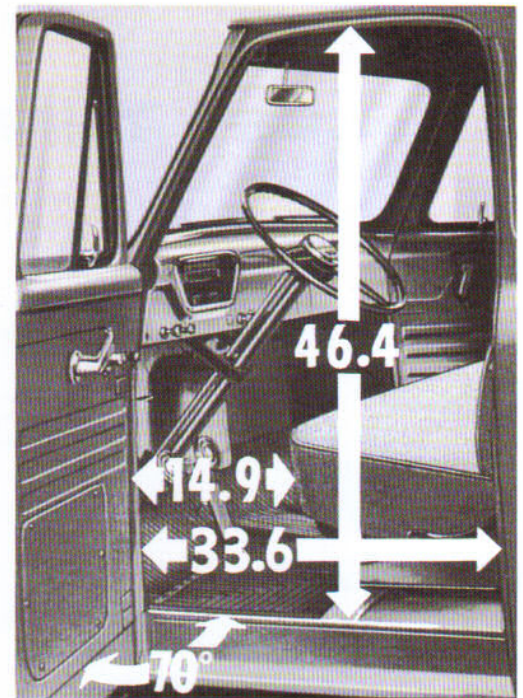

Wide door opening, almost a full yard wide, lets the biggest driver slip in and out easily. Door checks hold doors firmly when fully open at a 70° angle. Leg and foot room to spare between seat corner and door pillar. Weather sealing around doors and body joints to keep out dust, fumes, moisture. (Interior of Standard *Driverized* Cab shown.)



New Custom *Driverized*

Cab seat has full foam-rubber cushioning, over five soft inches deep in seat, three inches in seat back. Woven plastic upholstery in either red or green herringbone pattern, harmonizing with body color chosen, has smooth grey vinyl facing and pleated bolster.



CUSTOM DRIVERIZED CAB (SHOWN) HAS 14

"CUSTOMIZED" EXTRAS, WELL WORTH SMALL ADDED COST

INTERIOR

1. Color-keyed two-tone upholstery with bolster on seat back.
2. 5-in. full foam-rubber seat cushion with 3-in. full foam-rubber seat back.
3. Customized door and complete trim.
4. Perforated thermacoustic headlining backed by 1-in. glass-wool insulation.
5. Sound deadener on floor and rear cab panels (std. on doors).
6. Grip-type arm rest on left door (driver's side).

EXTERIOR

7. Large dome light with manual switch.
8. Two adjustable sun visors.
9. Illuminated cigar lighter.
10. Custom Cab identification plate.
11. Bright metal lead edge on upper grille bar.
12. Bright metal frames around Air Wing vents.
13. Bright finished drip molding cap.
14. Matched key locks on both doors.

Choice of 2 higher powered, long

COST CLIPPER SIX

Now! 118 h.p.

Ford engines—Six and modern LOW-FRICTION Greater gas savings!

Take your choice of V-8 or Six—both of these overhead-valve Ford Truck engines give you modern, money-saving short-stroke design!

In Ford's short-stroke engines, pistons travel a shorter distance, at slower speeds. Combined with high-compression, high-turbulence combustion, this cuts power-wasting internal friction . . . enables the engine to deliver more usable power from every gallon of regular gasoline.

Since there's less friction, there's less wear on vital moving parts. Piston ring life, for example,

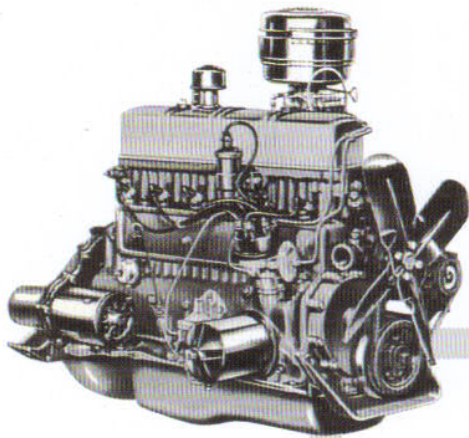

Displacement—223 cu. in.
Brake Horsepower—118 at 3800 r.p.m.
Torque—195 lbs.-ft. at 1200-2400 r.p.m.
Bore—3.62 in.
Stroke—3.60 in.
Compression Ratio—7.5 to 1

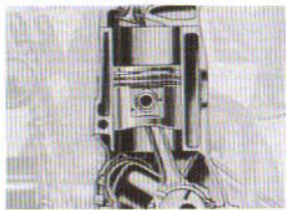

MODERN SHORT-STROKE

design cuts piston travel and piston speeds . . . saves gas . . . reduces friction wear on vital moving parts for much longer, lower-cost engine life.

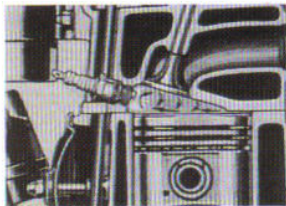

MORE COMPLETE COMBUSTION

is made possible by higher-compression wedge-shaped combustion chambers . . . which burn fuel efficiently, produce most power from least gas.



DEEP-SKIRT CRANKCASE

with wide-base flywheel housing for greater structural rigidity, smoother performance, longer engine life. Retains precise bearing alignment, provides solid support for crankshaft.

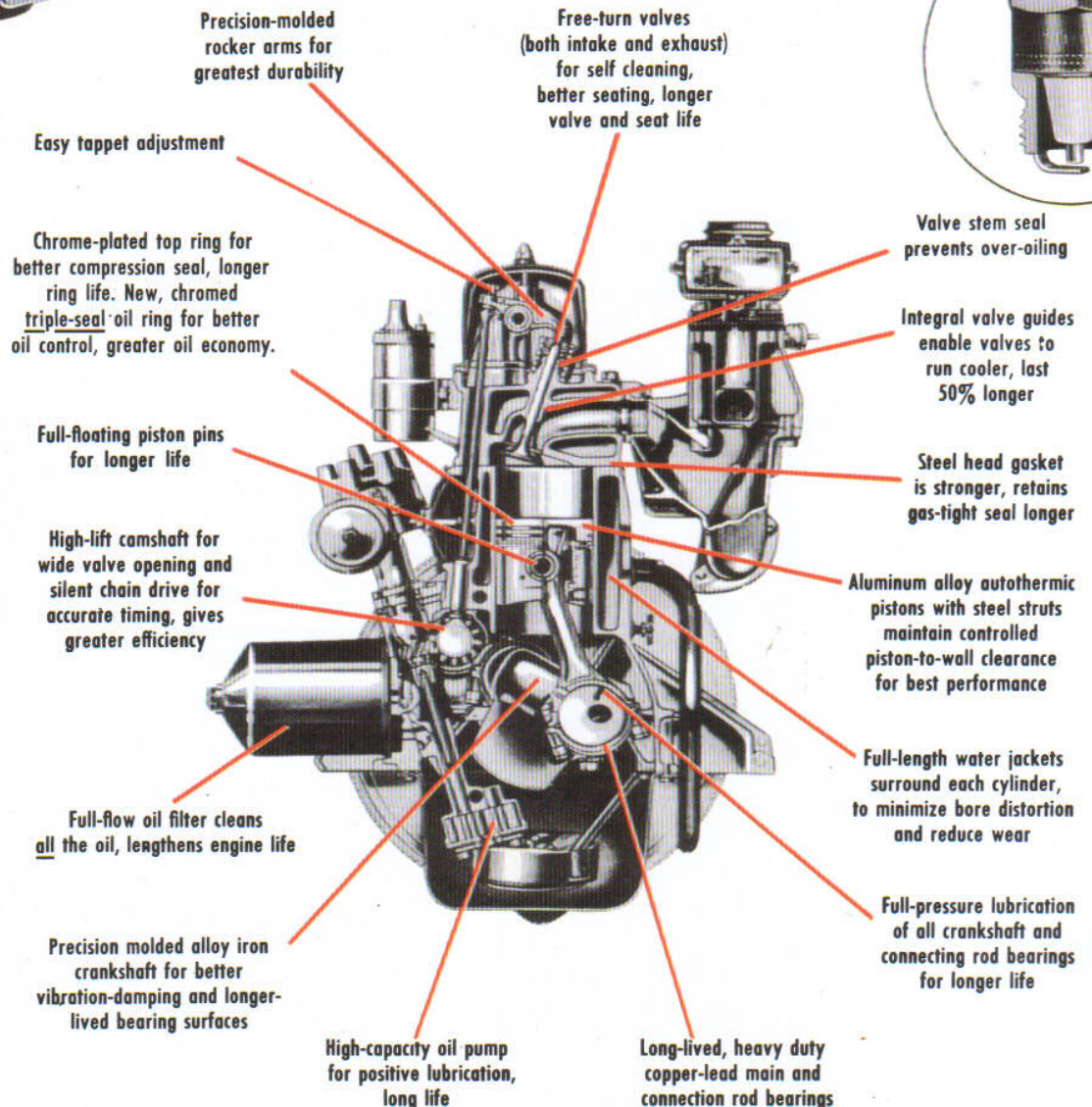

er lasting, SHORT STROKE engines!

V-8 have the most design in trucks today! Longer engine life!

POWER KING V-8

Now! 132 h.p.

is greatly prolonged. Engine blocks have a deep-skirt crankcase for higher structural rigidity and smoother performance. The entire engine lasts longer—costs less to run *and* less to maintain!

The basic design of these engines is so new that most other truck makers are just beginning to change over to it. Yet Ford's modern engines are *proved* engines—*economy proved* by over 5 billion miles on the job! And for '55, they offer important new durability features for still longer, lower-cost life!

Displacement—239 cu. in.
Brake Horsepower—132 at 4200 r.p.m.
Torque—215 lbs.-ft. at 1800-2200 r.p.m.
Bore—3.50 in.
Stroke—3.10 in.
Compression Ratio—7.5 to 1

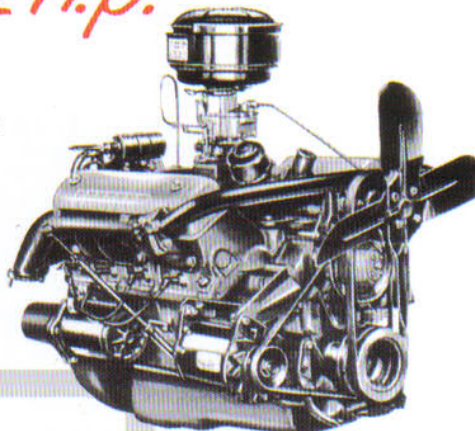

New, longer-lived, 18-mm. "Turbo-Action" spark plugs—a Ford first! Tapered seat, without gasket, positions plug for accurate firing. Plugs resist fouling with light loads, prolong peak power at full loads. On all Ford engines.

Precision-molded rocker arms for greatest durability

Easy tappet adjustment

Valve stem seal prevents over-oiling

Integral valve guides enable valves to run cooler, last 50% longer

Steel head gaskets are stronger, retain gas-tight seal longer

Chrome-plated top ring for better seal, longer life. New, chromed triple-seal oil ring for greater oil economy.

High-lift camshaft for wide valve opening and silent chain drive for accurate timing, gives greater efficiency

Full-flow oil filter cleans all the oil, lengthens engine life

High-capacity oil pump for positive lubrication, long life

Precision-molded alloy iron crankshaft for better vibration-damping and longer-lived bearing surfaces

Free-turn valves (both intake and exhaust) for self-cleaning, better seating, longer valve and seat life

Higher-compression, wedge-shaped combustion chambers for most efficient combustion and greater power output

Aluminum alloy autothermic pistons with steel struts maintain controlled piston-to-wall clearance for best performance

Full-length water jackets reduce wear. Higher capacity water pump increases cooling at idling and low speeds

Long-lived, heavy duty copper-lead main and connecting rod bearings

Full-pressure lubrication of all crankshaft and connecting rod bearings for longer life

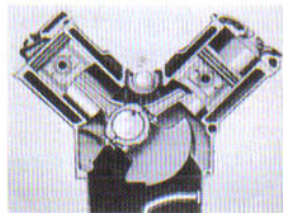

SHORT-STROKE DESIGN means greater power with less engine effort . . . more truck miles on the same piston travel . . . longer life for piston ring and other moving parts.

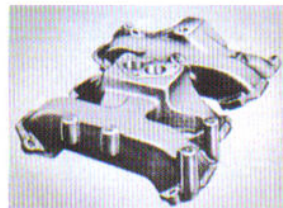

SHORT-REACH MANIFOLDS deliver fuel quickly on intake (shown). Larger exhaust manifolds remove burned gases faster. New exhaust heat control valve is more durable promotes faster warm-up.



DEEP-BLOCK DESIGN with reinforced, deep-skirt crankcase, provides solid foundation for support of crankshaft and greater rigidity to provide maintenance of bearing alignment. Prolongs engine life

Here's the sturdiest chassis of any half-tonner . . . and it's engineered to last!

1. Choice of modern, short-stroke 118-h.p. *Cost Clipper Six* (shown) or 132-h.p. *Power King V-8*.

2. Ford **Power Pilot** fully automatic carburetor-distributor, for most power from least gas.

3. **Air cleaner**, 1-qt. oil bath type, to prolong engine life.

4. **Engine mounting** rubber-cushioned for long life, smooth operation; easier engine servicing.

5. Large cooling capacity flat tube and fin **radiator** with long-life U-type support.

6. **Channel bumper** attached to extended frame for greater protection and rigidity.

7. Long, easy-action **front springs**—double-wrapped rear eyes for safety, shackled at front for stable steering.

8. Set-back, wide-tread **front axle** for shorter turning, more stability.

9. **Tie rod ends** are spring loaded, ball-socket type, with dust shields, for automatic wear take-up, longer life.

10. Double-acting **shock absorbers**, front and rear, for comfortable, level-ride control.

11. **Battery** safely located away from engine heat.

12. Roll Action **steering** for quicker response, easier handling.

Chassis models available:
Chassis with cab, with windshield, with cowl.

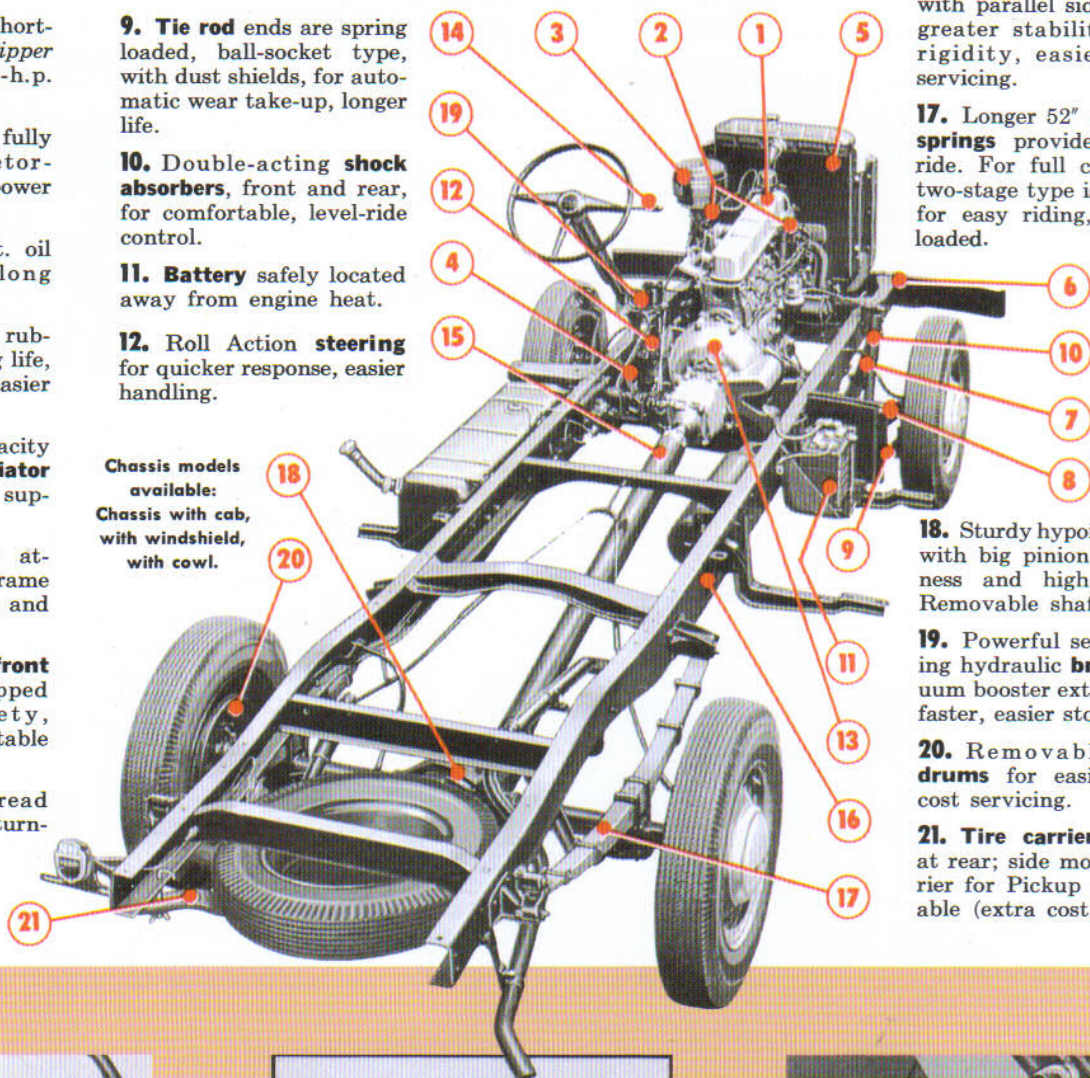

13. 10-in. Gyro-Grip **clutch** multiplies grip with increased speed; low pedal pressure, high plate pressure for easier operation, longer life.

14. Steering column **gear-shift**; Drive Selector with *Fordomatic*; greater driving ease.

15. Straight-line drive, with large diameter tubular **propeller shaft** for smooth power flow, longer U-joint life.

16. Deep-channel **frame** with parallel side rails for greater stability, higher rigidity, easier engine servicing.

17. Longer 52" 6-leaf **rear springs** provide a softer ride. For full capacity, a two-stage type is available for easy riding, empty or loaded.

18. Sturdy hypoid **rear axle** with big pinion for quietness and high strength. Removable shafts.

19. Powerful self-energizing hydraulic **brakes**; vacuum booster extra cost, for faster, easier stopping.

20. Removable **brake drums** for easier, lower-cost servicing.

21. **Tire carrier** mounted at rear; side mounted carrier for Pickup also available (extra cost).

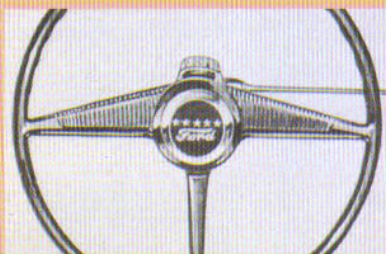

MORE VERSATILE FORDOMATIC DRIVE has new low gear "step-down" for faster acceleration, more power at the start. Now smoother, quieter, sturdier—fully automatic *Fordomatic* provides exactly the right torque requirements to match changing driving conditions. Negotiates over 30° grades with ease, even from a standing start. Available at low extra cost.

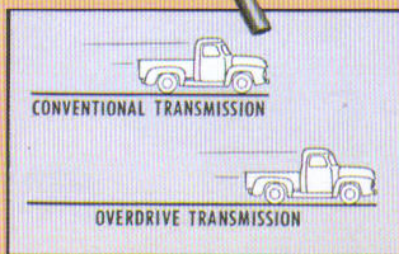

GAS-SAVING OVERDRIVE enables the truck to travel 43% farther at the same engine speed. Gives gas savings up to 15%. Overdrive transmission (extra cost) gives outstanding economy, smooth power-flow performance. 3-speed Synchro-Silent transmission is standard. Designed for smooth, easy, quiet shifting. Also available at extra cost are H. D. 3-speed and 4-speed types.



POWER BRAKING makes stopping up to 25% easier. Optional at extra cost, Power Braking boosts regular hydraulic actuation for smooth, fast stops with least effort and minimum pressure on the brake pedal. In fact, Power Braking requires less pedal pressure to bring truck to a full stop than would be required to break an ordinary light bulb! A Ford first in the half-ton field.

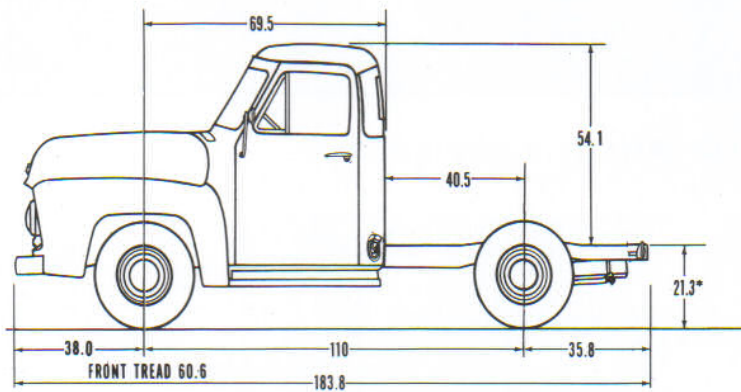

*WITH 6.00-16 6-P.R. TIRES (LOADED)

SERIES F-100 CHASSIS-CAB TAKES ANY CUSTOM-BUILT BODY FROM 5½ TO 6½ FT.

Ford F-100 Chassis-Cab, and Chassis-Cowl models are available on the 110-inch wheelbase for special purpose bodies to fit your specific loadspace requirements. Body and payload capacity (with equipment and driver) go up to 2,068 lbs. for the chassis-cab (see *Capacity Chart* below) and up to 2,568 lbs. for the chassis-cowl.

CAPACITY CHART—SERIES F-100 CHASSIS WITH CAB

TIRES—five. SIZE—front, rear and spare.	6.00-16 4-p.r.	6.00-16 6-p.r.	6.50-16 6-p.r.
GROSS VEHICLE WEIGHT RATING (Severe Service Rating)	4000 lbs.	4400 lbs.	5000 lbs.†
*CURB WEIGHT (with fuel and water) (est.)			
Front	1980 lbs.	1984 lbs.	1992 lbs.
Rear	890 lbs.	896 lbs.	940 lbs.
Total	2870 lbs.	2880 lbs.	2932 lbs.
*PAYLOAD, BODY, EQUIPMENT, ETC. (approx.)	1130 lbs.	1520 lbs.	2068 lbs.

*With Six engine. For V-8 engine, add 100 lbs. to "front" and "total" weights and deduct like amount from "payload."
†With heavy-duty rear springs.

SERIES F-100 BODY SPECIFICATIONS—CONDENSED

<p>6½-FT. PICKUP BODY</p> <p>BODY—riveted and bolted steel construction; smooth side panels with no wheelhouse obstruction.</p> <p>CORNER POSTS—box type of husky steel; welded to body.</p> <p>FLOOR—sturdy, seasoned wood protected by steel skid strips.</p>	<p>FRONT PANEL—full height, reinforced.</p> <p>LOADSPACE—unobstructed, no wheelhouse; 78.0" long; 49" wide; 20.3" to top of flare; 45 cu. ft. capacity.</p> <p>LOADING HEIGHT—24.2", floor to ground, loaded, with standard tires.</p>	<p>STAKE POCKETS—four, in corner posts for mounting uprights.</p> <p>TAILGATE—heavy, stamped steel, overlapping clamp-tight panel design, reinforced edge. Toggle-type latch clamps tailgate firmly to body sides for better seal. Anti-rattle drop chain.</p>
<p>8-FT. PANEL BODY</p> <p>BODY—reinforced welded steel; top and side panels shaped and welded to rear fenders.</p> <p>DRIVER'S COMPARTMENT—spacious; curved one-piece windshield; weather-sealed windows, doors. Sound deadener on all doors. Individual type driver's seat. 4" adjustment. Custom Panel has many features for added riding ease, style and driver efficiency. Auxiliary seat and I-REST tinted glass available at extra cost.</p> <p>FLOOR—solid plywood, well supported.</p>	<p>ported. Steel skid strips. Dust-moisture-sealed at side panels.</p> <p>INTERIOR—steel panel-protected sides, floor to top of wheelhouses—Panel has metal slats above; Custom Panel has heavy masonite lining above wheelhouses on panel sides, and perforated headlining backed by thick glass wool insulating pad extending full length of roof panel.</p> <p>LOADSPACE—96.9" max. length at floor (138.5" alongside driver); 62.2" wide; 53.2" high. Total capacity (including space beside driver) 155.8 cu. ft.</p>	<p>LOADING HEIGHT—23.9", floor to ground, loaded.</p> <p>LOCKS—matched, right hand rear panel and right side (Panel), matched on all doors (Custom Panel).</p> <p>REAR DOORS—hinged to welded one-piece steel door frame; fitted with soft rubber seals. 2-position door checks 90° or full open.</p> <p>REAR DOOR OPENING—50.8" wide, 45.4" high.</p>
<p>6½-FT. PLATFORM & STAKE BODY</p> <p>LOADSPACE—platform: 85.6" long x 71.3" wide; stake: 80" long, 67" wide, 29.5" high stakes.</p> <p>LOADING HEIGHT—32.8" with standard tires, loaded.</p> <p>FLOOR—sturdy seasoned wood, protected by steel skid strips.</p>	<p>PLATFORM—bridge-type construction; heavy gage steel framing riveted to cross girders; steel angle brackets riveted to girders. Corners reinforced with steel gusset plates.</p> <p>STAKE RACKS—removable; sturdy, straight-grained wood; one-piece side and end sections.</p>	<p>RACK INTERLOCKING PLATES—strong-holding, easily locked. Bolted to rack boards.</p> <p>RUB RAILS—steel, around platform; steel caps on ends of body sills for protection.</p> <p>STAKE POCKETS—flush with floor steel lined; welded inside of frame rail, riveted outside.</p>

F-100 SPECIFICATIONS

MAXIMUM GROSS VEHICLE WEIGHT 5,000 POUNDS

AXLE, FRONT

Capacity—lbs.	2600
Type	Modified I-Beam
Size (Height x Width x Web)—in.	2.29 x 1.67 x 0.32

AXLE, REAR

Capacity—lbs.	3300
Type	Hypoid—Semi-Floating
Axle Ratio—With 3- or 4-speed Transmission	3.92 to 1 or 4.27 to 1
With Overdrive Transmission	4.09 to 1 or 4.27 to 1
With Fordomatic	3.92 to 1

BRAKES, SERVICE

Type	Hydraulic, Two-Shoe, Single Anchor, Self-Energizing
Front Brake (Drum Diam. x Lining Width—Thickness)—in.	11 x 2—3/16
Rear Brake (Drum Diam. x Lining Width—Thickness)—in.	11 x 1 1/4—3/16
Total Area: Drum—Lining—sq. in.	259—179

BRAKE, HAND

Cable with Equalizer applying Rear Wheel Brakes

BUMPER

Type.....Curved, Truck-Type Channel Mounting
Bolted Direct to Front Frame Side Rails

CLUTCH

Type.....Gyro-Grip, Semi-Centrifugal Single Plate
Diameter, in.—Frictional Area, sq. in.....10—85.5
Clutch Disc.....Cushioned Hub with Vibration Damper
Release Bearing.....Impregnated Bronze Bush
Attachment—Levers to Pressure Plate.....Needle Roller Bearings

COOLING SYSTEM

Capacity—qts.	18 1/2
V-8	22
Radiator	Flat Tube and Fin—Pressure Cap
Thermostat(s)	In Engine Water Outlet(s)
Fan, Diameter—in.: Six	18—4-Blade
V-8	18—4-Blade

DRIVE LINE

Type.....Hotchkiss, Straight-Line Drive
Propeller Shaft—Number.....One, Tubular, Forged Steel Ends
Dia., in.....2.5 with O.D. and Fordomatic, 3.5 with std. Trans.
Universal Joints—Number, Type.....Two, Needle Roller Bearing

ELECTRICAL SYSTEM

Battery.....6-Volt, 17-Plate, 90-Amp. Hr. Capacity
Generator.....35 Amp. 250 Watts
Ignition.....Full Vacuum Controlled System Fully Automatic Distributor, Metal-Clad; Open Wiring in Rubber Grommets with Moisture-Proof Boots Over Spark Plugs
Head Lights.....Sealed Beam, Foot-Switch Beam Control
Starter.....High Torque, Automatic Engagement, Solenoid Switch, Push-Button Control
Parking Lights; Left-hand Combination Stop and Tail Light (Dual Tail Lights Standard on Panel); Instrument Lights; Ignition Switch with Key Lock; Circuit Breakers; Voltage Regulator.

ENGINES

	COST CLIPPER SIX	POWER KING V-8
Bore and Stroke, in.	3.62 x 3.60	3.50 x 3.10
Displacement—cu. in.	223	239
Max. Brake Horsepower @ RPM	118 @ 3800	132 @ 4200
Max. Torque—Lbs.-Ft. @ RPM	195 @ 1200-2400	215 @ 1800-2200
Compression Ratio	7.5 to 1	7.5 to 1

FRAME

Side Rails—Type.....Parallel, Channel Section—with 4 Cross Members
Max. Section (Depth x Flange x Thick.) in.....5.92 x 2.25 x 0.15
Cross Members.....4—Flanged "U" Type and Channel Section
Section Modulus.....2.65

FUEL SYSTEM

Carburetor.....Downdraft
Air Cleaner.....Heavy Duty Oil Bath, One Qt. Capacity
Fuel Pump and Filter.....Diaphragm Type, Driven from Camshaft
Fuel Tank—Chassis without Cab.....17-Gal. Inside Left Frame Rail
Chassis with Cab.....17-Gal. Outside Left Frame Rail Below Cab
Fuel Filler.....Tube Extension to Outside Cab or Body

LUBRICATION

Engine.....Full Pressure Feed
to all Main, Crankpin and Camshaft Bearings
Crankcase Capacity (with opt. oil filter).....6 qts. (dry); 5 qts. (refill)
Chassis.....Fittings for Pressure Lubrication

SHOCK ABSORBERS

Front and Rear.....Direct, Double Acting, Telescopic

SPRINGS —Semi-Elliptic, Leaf Type, Ford Alloy Steel	<i>front</i>	<i>rear</i>
Length x Width—in.	42 x 1 1/4	52 x 2
Number of Leaves and Def. Rate—lbs. per in.	8—238	6—166
Capacity at Spring Pad (Normal Def.)—Per Spring, lbs.	950	1025

NOTE: With 6.50-16 6-p.r. tires, optional heavy duty 9-leaf two-stage rear springs are required—def. rate 172 lbs. and 258 lbs. per in.; capacity at spring pad (normal deflection) 1350 lbs. per spring.

STEERING

Type.....Worm and Dual Row Needle Bearing Roller Ratio.....18.2 to 1
Wheel.....18 in. Dia., 3-Spoke
Turning Circle Diameter, Right or Left—ft.....37.1
Tie Rod.....Ball Stud and Socket, Spring Loaded for Automatic Take-up of Wear, Equipped with Rubber Dust Shields

TRANSMISSION

Standard	3-Speed, All-Helical Synchro-Silent, Steering Column Shift
Optional (extra cost)	Heavy Duty 3-Speed Synchro-Silent, Steering Column Shift
Optional (extra cost)	3-Speed Synchro-Silent with Overdrive, Steering Column Shift
Optional (extra cost)	Fordomatic, Selector Lever on Steering Column
Optional (extra cost)	4-Speed Synchro-Silent, Center Shift
Gear Positions	<i>First</i> <i>Second</i> <i>Third</i> <i>Fourth</i> <i>Reverse</i>
Ratio (to 1): Std. 3-Speed	2.78 1.62 1.00 — 3.375
Opt. H.D. 3-Speed	3.71 1.87 1.00 — 4.59
Opt. Overdrive	2.78 1.62 1.00 .070 3.375
Opt. 4-Speed	6.40 3.09 1.69 1.00 7.82
Opt. Fordomatic*	2.44 1.48 1.00 — 2.00
*Converter stall torque ratio2.1 to 1

WHEELS AND TIRES

Wheels.....Five—16-inch Steel Disc with 0.62-inch Offset;
5 Hole, 5.5-inch Dia. Bolt Circle
Rims—Size and Type.....16 x 4 1/2 K, Drop Center
Tires—Standard Size—Front, Rear and Spare.....Five—6.00-16 6-ply rating

STANDARD EQUIPMENT in addition to items specified above:

Center Cowl Ventilator	Dual Windshield Wipers*	Fenders, Rear—on Pickup & Panels (Splash Guards on Stake and Platform)
Curved Instrument Panel*	Air Wing Ventilating Windows in Doors*	Running Boards—Long on Pickup and Chassis-Cab
Speedometer	Door Lock—Right Door on Cab, Right Door and Rear Door on Panel	Short on Panels, Stake and Platform
Water Temperature Gage	Sun Visor—Left side in Cab and Panel	Rear Bumper (Panels Only)
Oil Pressure Gage	Mirror, Rear View—Inside on Pickup	Diagonal Type Spare Tire Carrier under Frame (under Floor on Platform and Stake)
Fuel Gage	Choke Button	Mechanical Jack and tool
Charge Indicator	Light Switch	Bright Hub Caps
Ash Receptacle	Single Electric Horn	
Dispatch Box	One-piece Curved Windshield*	

NOTE: Running boards are not standard on chassis with cowl.

*Except Chassis Cowl.

STANDARD COLORS:

Choice of Raven Black, Banner Blue, Waterfall Blue, Meadow Green, Goldenrod Yellow, Vermilion, Regatta Blue or Mountain Green (on hood, fenders, cowl, bodies of panel, pickup, and stake models interior metal, and running boards on panel models). Wheels on all models are Snowshoe White. Snowshoe White is also available on Custom Cab roof and rear upper panel as a two-tone combination with standard body colors. The following are painted black: Frame, running boards (except panel models), tail lamp, springs, axles, outside mirror, door divider bar, vent window frame, fuel tank cap (except panel models), and bumpers. Cowl models are painted prime unless standard color is specified.

AVAILABLE EQUIPMENT AND ACCESSORIES at extra cost:

Battery—120-Amp. hr.	Mirror, Outside Rear View, Right or Left, 6" Adjustment	Tail Light—Right Hand (Std. on Panel)
Brakes—Vacuum Booster	Mirror, Arm Braces	Tinted Glass
Bumper, Rear, for Pickup Cab, Custom	Oil Filter	Tires: 5—6.00-16 4-p.r.*
Carrier, Spare Tire—Side Mounted (Pickup only)	Panel, Custom	5—6.50-16 6-p.r.*
Clutch, 11-inch, for H.D. 3-speed trans.	Radiator, Heavy Duty	Tow Hooks
Directional Turn Signals	Radiator Grille Guards—Heavy Duty	Transmissions—H.D. 3-Speed 4-Speed (including 11-inch clutch) Overdrive Fordomatic
Engine Compartment Lamp	Radio	Visor
Fire Extinguisher (1 1/2 qt.)	Reflector Flares (3 in kit) with Flares	Windshield Washer
Governors	Road Lamps	Windshield Wipers—Positive Action, Dual Electric
Hand Brake Signal	Seat, Auxiliary (Panel)	*Heavy duty rear springs required.
Heater and Defroster—Magic Aire System or Recirculating	Seat Cover	
Locking Gas Tank Cap	Spotlight with Bracket	
	Springs, Rear, Heavy duty Two-stage Type	
	Stop Lamp	

These specifications were in effect at the time this folder was approved for printing. The Ford Division of the Ford Motor Co., whose policy is one of continuous improvement, reserves the right, however, to discontinue models or change at any time, specifications, design or prices without notice and without incurring any obligation. Availability of equipment, accessories and trim is dependent on material supply conditions.