

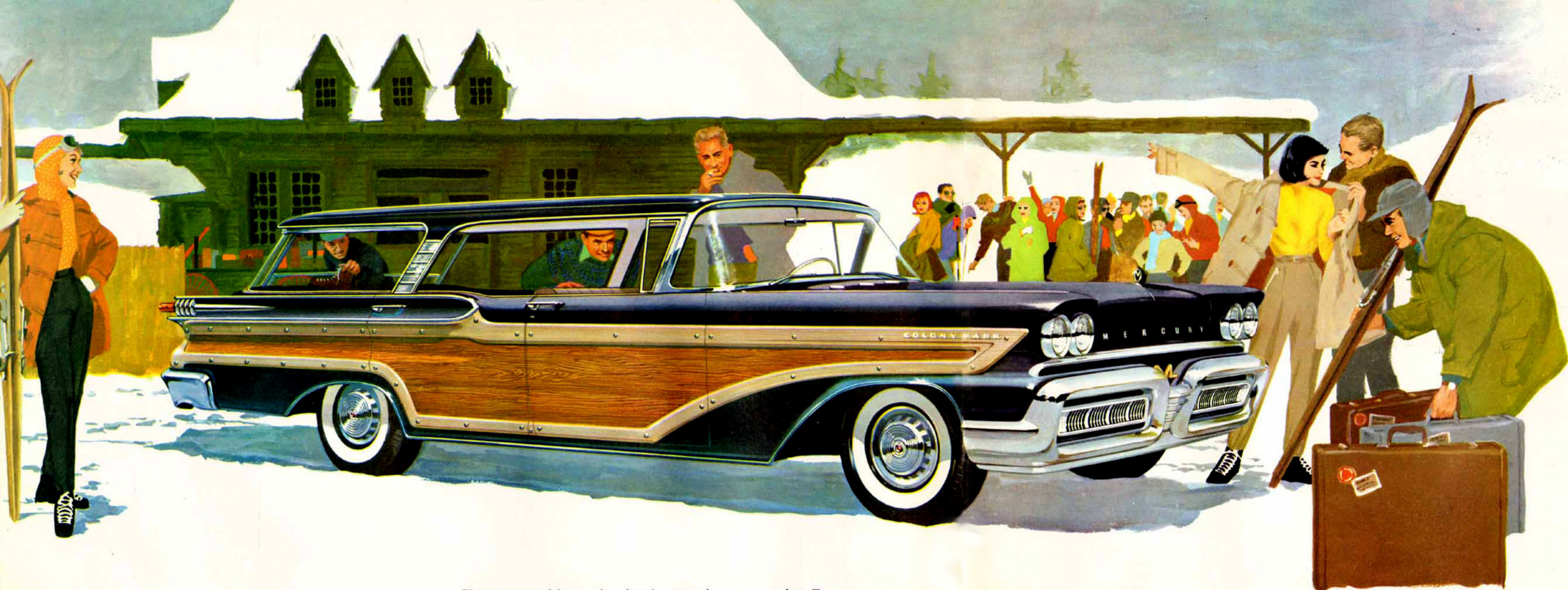

1958 MERCURY HARDTOP STATION WAGONS

With Spirit to Match Their Beauty and Size · 3 Great Series · 6 New Models



Big M Station Wagons with Hardtop Styling

Superlative performance • True passenger-car comfort • Limousine Ride . . . solid, smooth and road-hugging • Many new features found on no other station wagons

Mercury's 1958 station wagons with Hardtop Styling again lead the field—with spirit to match their beauty and size. They offer superlative performance plus comfort in abundant measure: Marauder engines with Cool-Power Design, and the industry's only Limousine Ride—a new kind of ride built into all Big M's.

Every Mercury station wagon has Hardtop Styling. The three awkward pillars common to many other station wagons are replaced in Mercury wagons by a single, graceful, extra-strong roof support. This gives passengers the full-view expanse of a *true* hardtop. In addition, Mercury's retractable back window eliminates the old-fashioned liftgate, permitting a flat, all-clear loading area on the open tailgate.

To make your 1958 station wagon even more enjoyable, Mercury offers many other features—including Advanced Keyboard Control Merc-O-Matic Transmission, new, larger, Super-Safe Self-Adjusting Brakes, Quadri-Beam Headlamps; and such options as Climate Dial Air Conditioner and Heater, Rear Radio Speaker, and Speed Limit Safety Monitor.

Look and compare . . . you'll find The Big M offers you the best station wagon value in a wide selection of models in three price ranges.

The Colony Park

The most masterful expression of station wagon luxury you can buy. To drive it is to command the highway . . . to relax in it is to experience comfort without compromise . . . to own it is real enjoyment—and justifiable pride. Luxury features include the distinctive, lasting beauty of wood-grained, steel paneling and fully carpeted floor and tailgate.

Illustrated is the Colony Park 4-door, 6-passenger—Solid-Toned Tuxedo Black. (Also available in 4-door, 9-passenger model.)

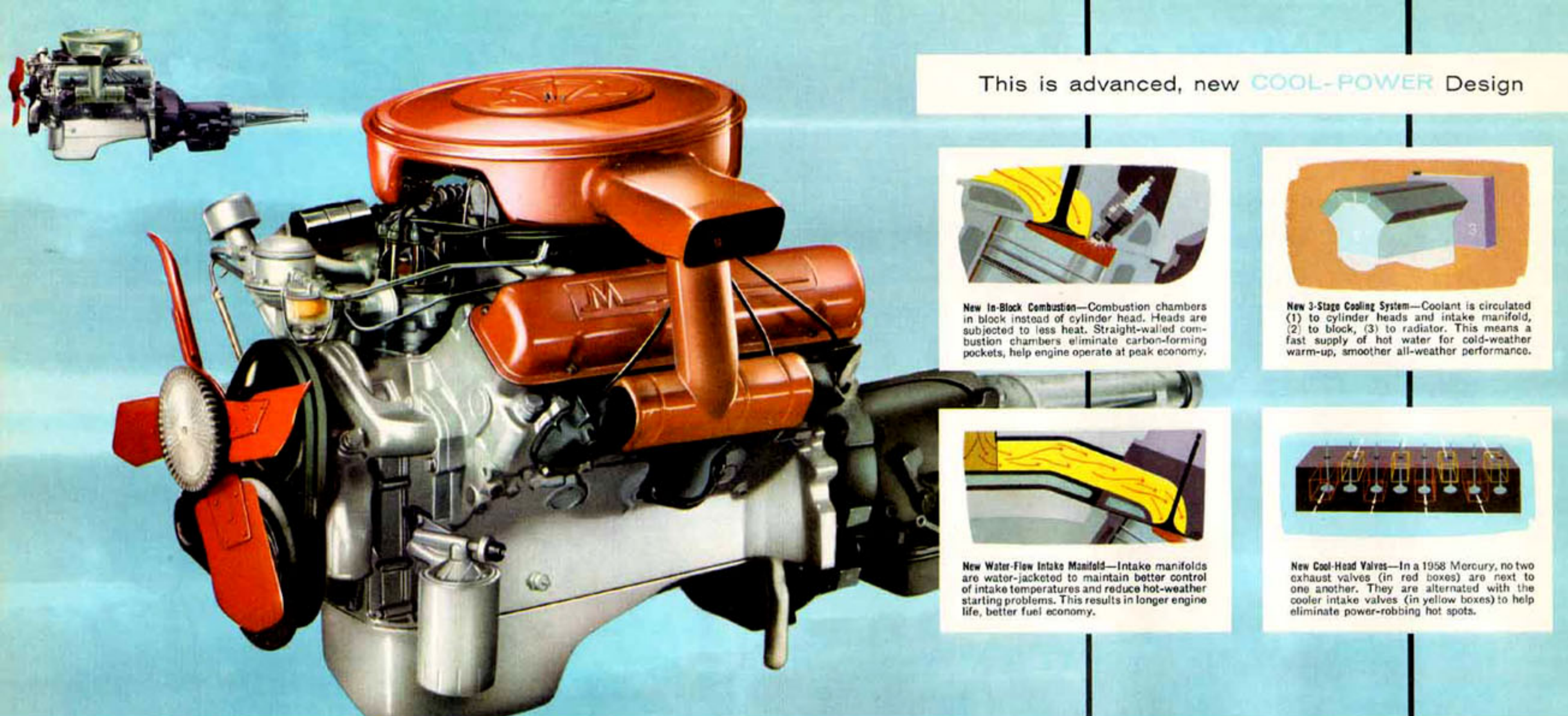

This is advanced, new **COOL-POWER** Design



New In-Block Combustion—Combustion chambers in block instead of cylinder head. Heads are subjected to less heat. Straight-walled combustion chambers eliminate carbon-forming pockets, help engine operate at peak economy.



New 3-Stage Cooling System—Coolant is circulated (1) to cylinder heads and intake manifold, (2) to block, (3) to radiator. This means a fast supply of hot water for cold-weather warm-up, smoother all-weather performance.



New Water-Flow Intake Manifold—Intake manifolds are water-jacketed to maintain better control of intake temperatures and reduce hot-weather starting problems. This results in longer engine life, better fuel economy.

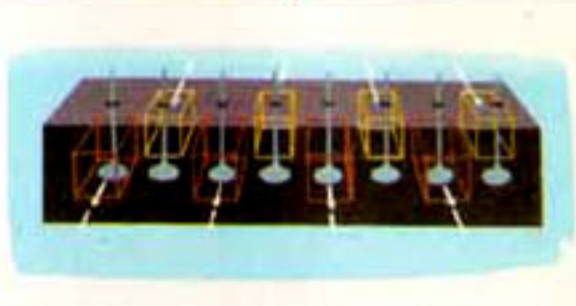

New Cool-Head Valves—In a 1958 Mercury, no two exhaust valves (in red boxes) are next to one another. They are alternated with the cooler intake valves (in yellow boxes) to help eliminate power-robbing hot spots.

312 HP MARAUDER 330 HP MARAUDER

For '58, a new family of Mercury Marauder V-8 engines with **COOL-POWER** Design

Up to 400 horsepower in the newest, most efficient engines ever created.

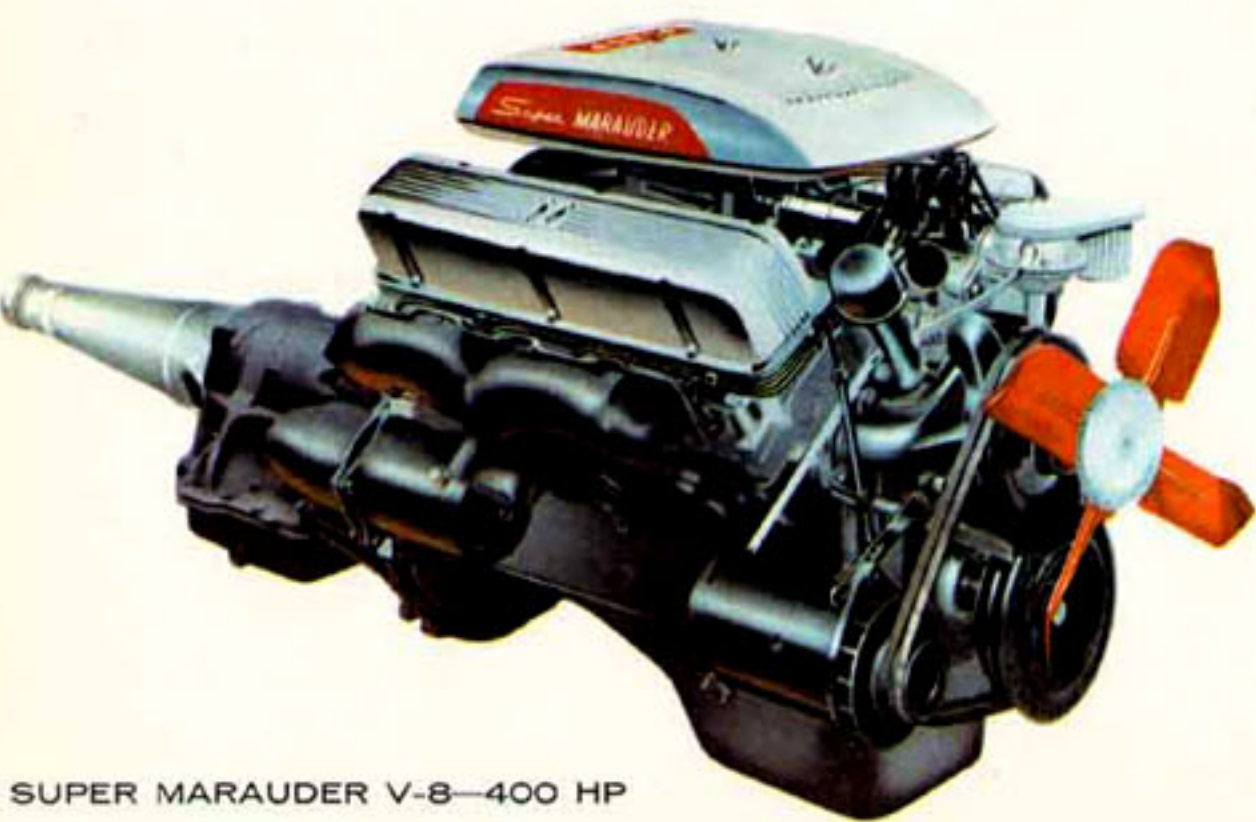

SUPER MARAUDER V-8—400 HP

Mercury's revolutionary Marauder V-8 engines with Cool-Power Design score a victory over heat and friction—deliver a new kind of power and performance never before achieved in any station wagon. Totally new, from the shape of the combustion chamber down to the last bolt and gasket, this new team of Big M Marauder engines outdates any other engine on the road. Each station wagon series has an engine tailored to its specific needs: 312 hp in the Commuter series, 330 hp in the Voyagers and Colony Park, and for those who demand the ultimate in performance, the 400 hp

Super Marauder, optional on all 1958 Mercury models. Some of the basic concepts which contribute to the new high in efficiency are new short-stroke, low-friction design, higher ratio of power to engine weight, 10.5 to 1 compression, 4-barrel Thermo-Matic carburetor, wedge-shaped, in-block combustion chambers. These spectacular engineering advances enable new Marauder V-8 engines to step up cooling efficiency, score an important triumph over power-robbing hot spots and friction, give you more complete combustion, faster all-weather starting, more power from less fuel.

Mercury's brilliant combination of road-smoothing features gives you new Limousine Ride...



IT'S LIKE LOUNGING IN YOUR LIVING ROOM

The most superb riding qualities ever put between you and the road give Big M station wagons a smoother, more level, cushion-soft ride than any car on the road—except another 1958 Mercury! It's solid, steady-as-it-goes Limousine Ride. Here is the greatest combination of bump-smothering, vibration-absorbing engineering advances ever to work together: full-cushion shock absorbers . . . swept-back ball-joint front suspension . . . new, softer springing action . . . scientific weight distribution . . . a new, low center of gravity. All these features, working together, give you *true* passenger-car comfort in every Big M station wagon. One ride in a 1958 Mercury station wagon will convince you that there's never been anything like this smooth, new Limousine Ride . . . you'll never want a station wagon without it.

A Big Plus in Performance



EASIER HANDLING

The lower suspension arms of the ball-joint front suspension are swept back slightly so that front wheels are "pulled" over bumps instead of being "pushed" into them. You get a softer, smoother ride, plus better control under all driving conditions.

Advanced Merc-O-Matic Drive Keyboard Control



Entirely new Keyboard Control answers the touch of your fingertip, and advanced Merc-O-Matic Drive delivers instant response in every driving range—on hill or highway, or in city traffic. The Keyboard starts the engine, controls neutral, reverse, drive, locks the car in gear for parking, and releases the parking brake. It even has a "Hill Control" button for engine braking on steep inclines. The greater torque capacity of the new, stronger Merc-O-Matic Transmission tailors the power of the Marauder engines to your command. And a high-economy rear axle gives you greater gas mileage. Standard on Colony Park and Voyager models, optional in the Commuter series.



BRAKES ADJUST AUTOMATICALLY

Another important Mercury safety and convenience feature, larger, Super-Safe Self-Adjusting Brakes help prevent swerving, provide surer stops. Brakes automatically compensate for lining wear. These big, new brakes have 233 square inches of effective braking area—front brake shoes are widest in Mercury history.

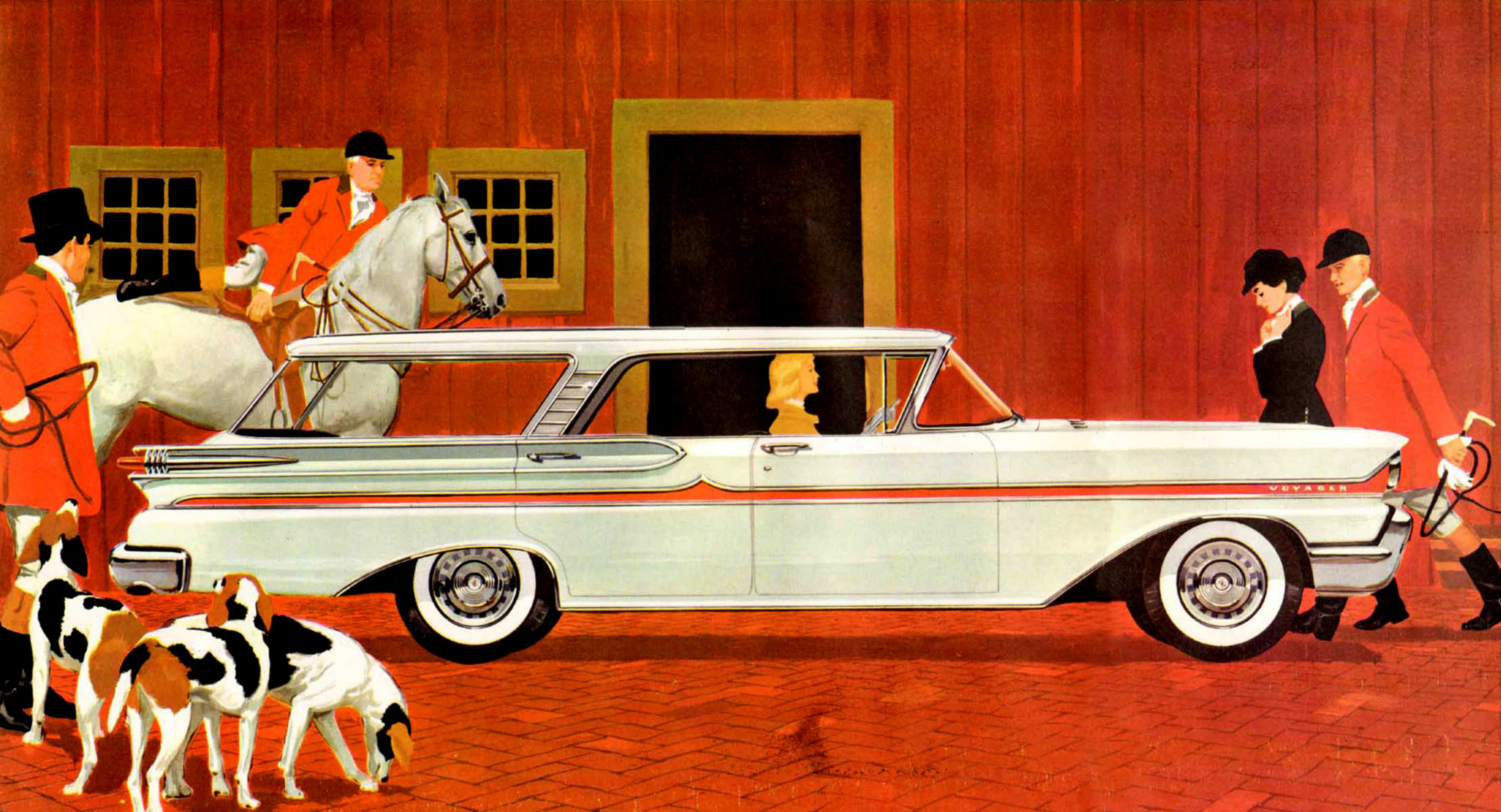

The Voyager Series

Equally wonderful for handy hauling, casual calling, and formal affairs, the Mercury Voyager affords all-purpose convenience. Glamorous and smart, it's a car designed to excite the more discriminating members of the station wagon set. Spectacular combination of Cool-Power Ma-rauder 330 hp V-8 with Limousine Ride takes back-country trail, traffic, and turnpike in stride. Handsome it is, appointed tastefully throughout, and every spacious inch is *usable* big. Other features you'll find on 1958 Big M station wagons are front-hinged hood, safety lock for second seat, toe-set parking brake, and slide-type, safety door locks.

VOYAGER 4-DOOR, 6-PASSENGER
Solid-Toned Marble White with Red Side Molding
(Also available in 4-door, 9-passenger model.)

VOYAGER 2-DOOR, 6-PASSENGER
Two-Toned Jamaican Blue Metallic and Marble White.



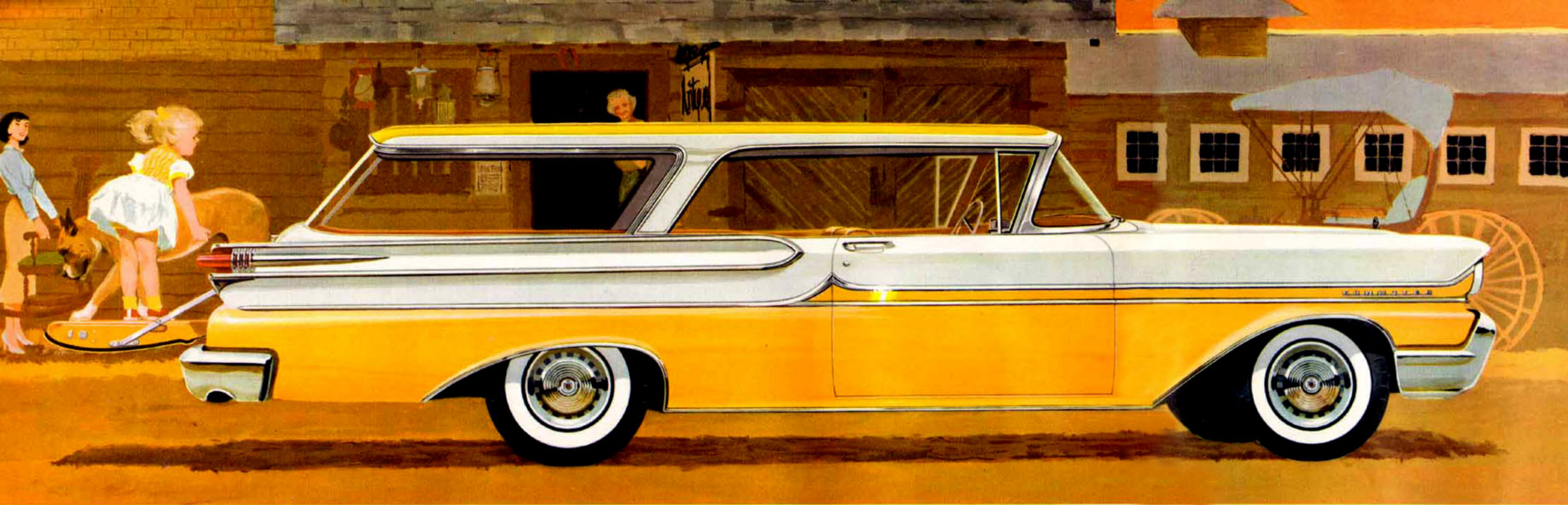

COMMUTER 2-DOOR, 6-PASSENGER
Flo-Toned Marble White and Mayfair Yellow.

Three big-value models all with Marauder-smooth performance . . . exclusive Limousine Ride . . . true hardtop design . . . features not available at any price in other make station wagons. Beautiful family car . . . versatile utility wagon, the stylish Big M Commuter affords plenty of room for the young family to grow in. And every Commuter has massive bumper-grille combination, Quadri-Beam headlamps, distinctive taillights that say "Mercury" at a glance. Never before has so much size, power, comfort, and so many years-ahead features been offered in a station wagon at such modest cost.

The Commuter Series



COMMUTER 4-DOOR, 9-PASSENGER
Solid-Toned Holly Green Metallic with White Side Molding.



COMMUTER 4-DOOR, 6-PASSENGER
Two-Toned Autumn Beige and Golden Dust Metallic.

A whole new world of station wagon elegance
... a new fashion in fabrics — a new note in color



INTERIORS THAT ARE BOTH LUXURIOUS AND DURABLE
— TO MEET THE DEMANDS OF STATION WAGON LIVING

Mercury has designed and created every interior element expressly for station wagon living: fabrics of easy-to-clean, leather-like vinyls and nylon-faced body cloth . . . artfully blended textures of enduring beauty . . . a rainbow of exciting colors—for vibrant contrast or subtle distinction. And you can choose from more than a score of stunning exterior paint colors. From the fully integrated instrument panel, high-luster chrome hardware, and lounge-like contour seats to scuff-resistant floor coverings, you are surrounded by a degree of luxury available only in Mercury station wagons.

A new concept of
practical spaciousness, too!

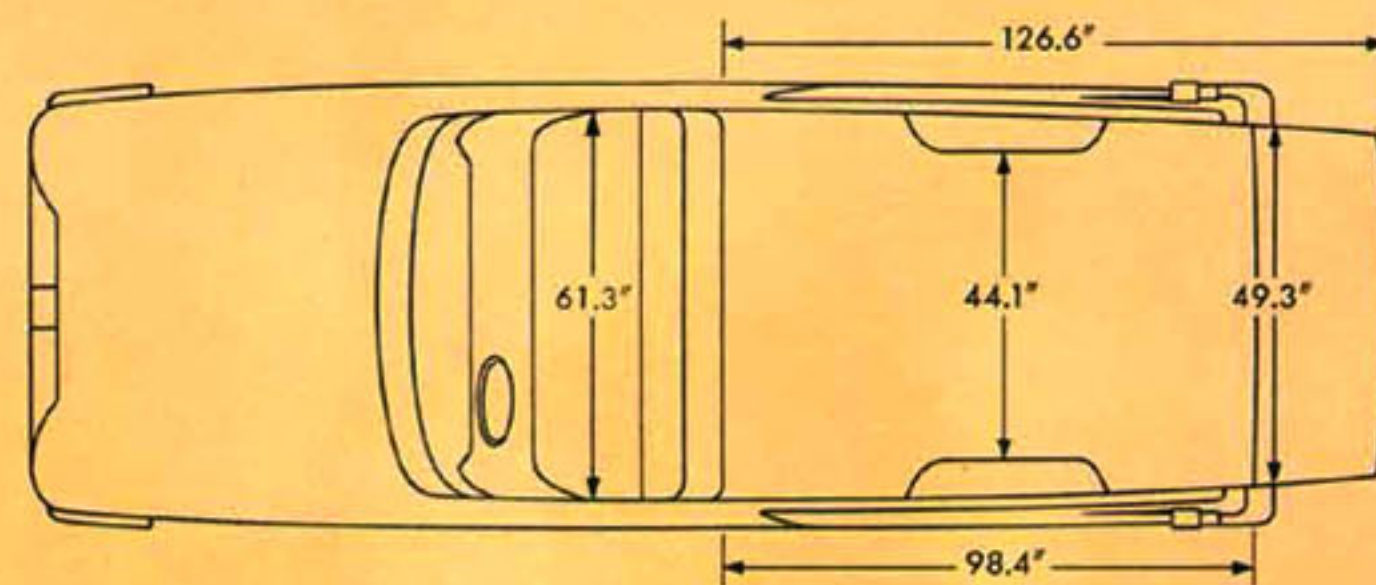

BIGGER IN ALL THE DIMENSIONS THAT COUNT

Over-all Length—214.2"	Rear of Front Seat to Rear of Floor Tailgate Opened—126.6" Tailgate Closed —98.4"	Floor to Roof Behind Front Seat—34.2"
Over-all Height—58.3"	Rear of 2nd Seat to Rear of Floor Tailgate Opened—88.6" Tailgate Closed —60.4"	Total Floor Area Behind Front Seat Tailgate Opened—49.0 sq. ft. Tailgate Closed —38.2 sq. ft.
Over-all Width—79.1"	Rear of 3rd Seat to Rear of Floor Tailgate Opened— 54.5" Tailgate Closed — 26.3"	Total Cargo Capacity Behind Front Seat—87.4 cu. ft. Behind 2nd Seat —48.0 cu. ft. Behind 3rd Seat — 4.8 cu. ft.
Tailgate Extension—28.2"		
Rear Opening Height—27.4" (vertical clearance)		
Rear Opening Width—49.3"		
Tailgate to Ground—25.6"		

Every 1958 Mercury station wagon has more than 87 cubic feet of all-clear load space, big enough to carry a rowboat *inside*. It's bigger in all the other dimensions that count, too! For example, when the tailgate is down, Mercury provides the largest, most versatile, *usable* area of any station wagon on the road. The back window retracts into the tailgate to completely eliminate the cumbersome liftgate, giving you a flat, open, loading platform. To transform your wagon into a sedan, fold up second seat in 6-passenger models, and add removable rear seat in 9-passenger models.

Station wagon accessories
for extra convenience and value



**POWER-OPERATED
RETRACTABLE BACK WINDOW**

Replacing the out-moded liftgate, this retractable window lowers into the tailgate to provide refreshing, rattle-free ventilation and all-clear loading when the gate is open. Available separately as a power option; manual-operated version standard on every Mercury wagon.

LUGGAGE CARRIER

This low-cost accessory enables you to carry all your luggage, sports gear, or camping equipment, in addition to a wagon-load of passengers. Sturdy, handsome construction of chrome-plated, die-cast metal and stainless steel. Available for either permanent or demountable installation.



REAR RADIO SPEAKER

Another new Mercury "first" for station wagons, this speaker "carries" the sound to every passenger with crisp clarity and richness. Volume can be regulated independently of the front speaker for acoustical balance and stereophonic realism. Installed behind a grille in the right rear corner of the wagon.

To add even more to your driving pleasure

Station Wagon Specifications



Climate Dial Air Conditioner and Heater—Simplicity itself—all-weather comfort at the touch of a single control knob. Air conditioning, heating or defrosting, and any degree of each, is yours in any season. The ultimate in fast, dependable, simple operation, the entire unit is front-mounted for maximum efficiency and comfort with no loss of usable room. Optional.



Power-Booster Fan—Rotates for engine cooling when car is traveling slowly. At highway speeds, when fan is not needed for cooling, fan clutch automatically limits rotation—saving power other cars usually waste. Boosts performance, cuts fuel consumption. Indicator on instrument panel tells when Power Booster is operating. Optional on all models.



Speed Limit Safety Monitor—A new approach to automotive safety. Set your desired speed, up to the legal limit, on the handsome dash-mounted dial—then relax and concentrate on your driving. Once you exceed your pre-set speed, a gentle bell sounds reminding you to slow down. The Speed Limit Safety Monitor is optional on all Mercury models.



Power Seat That "Remembers"—Now you can dial your most comfortable seat position! Set your favorite position on the instrument panel dial and forget it—but the seat won't! When the ignition key is turned off, the seat automatically moves backward for easier exit or entry—returns to your "set" position when the key is turned on. Optional on all Mercury models.

ENGINES

COMMUTER MODELS: 312-hp, 383 cubic inch displacement. Torque rating, 405 lb.-ft. Compression ratio 10.5 to 1. Cylinder bore, 4.3 in. Piston stroke, 3.3 in.

VOYAGER AND COLONY PARK: 330-hp, 383 cubic inch displacement. Torque rating, 425 lb.-ft. Compression ratio 10.5 to 1. Cylinder bore, 4.3 in. Piston stroke, 3.3 in.

SUPER MARAUDER: 400-hp, 430 cubic inch displacement. Compression ratio 10.5 to 1. Three 2-barrel carburetors. Cylinder bore, 4.3 in. Piston stroke, 3.7 in. Available as special order option with Multi-Drive Merc-O-Matic.

BASIC CONSTRUCTION: One-piece V-8 cylinder block. In-block combustion chambers. Water-cooled intake manifold. Cool-Power Design eliminates hot spots. Aircraft-type, low-friction pistons with step top and 4.3-inch diameter.

FUEL SYSTEM: Low-silhouette 4-barrel Thermo-Matic carburetor. Dual temperature-controlled carburetor air intakes. Dry-type carburetor air filter.

ENGINE LUBRICATION: Full-pressure lubrication with simplified pattern. Internally mounted rotor-type oil pump. Capacity, 5 quarts. Forced-air crankcase ventilation.

ELECTRICAL: 12-volt system. High-capacity dual-drive generator with low cut-in speed. Battery size—66 plates for vehicles with conventional or overdrive transmission; 78 plates with Merc-O-Matic transmission. High torque "Folo-Thru" starter. Combination centrifugal-vacuum spark advance control. Front-mounted distributor.

OVERHEAD VALVES: Free-turning, rotating type valves. Intake valve-head diameter 2.08 in. for 383 cu. in. engines; 2.14 in. for 430 cu. in. versions. Exhaust valve-head diameter 1.77 in.

COOLING SYSTEM: 3-stage cooling with 21½ quart capacity (with optional heater). 3 thermostats adjust cooling capacity to needs.

EXHAUST SYSTEM: Center-outlet exhaust manifold with extra-large passages.

POWER TRAIN

MERC-O-MATIC TRANSMISSION: Combination of fluid torque converter and 3-speed planetary gear train. Mechanical Keyboard Control drive selector. (Optional for Commuter models.) Oil capacity 10¼ quarts.

CONVENTIONAL TRANSMISSION: Selective gear type with three speeds forward, one reverse. All gears helical. Constant-mesh second gear. Overdrive with 4th forward speed (.72 to 1 ratio) optional for Commuter models.

REAR AXLE: Hypoid gears with straddle-mounted pinion gear. Rear axle ratio is 2.69 to 1 with 312-hp and 330-hp engines, and 2.91 to 1 with 360-hp or 400-hp engines. All air conditioned Mercury vehicles have 2.91 to 1 rear axles. With conventional transmission or overdrive, the rear axle ratio is 3.56 to 1.

CHASSIS

FRAME: Ladder-type with outward curved side rails, and 5 cross-members. Side rails internally and externally reinforced.

FRONT SUSPENSION: Independent ball-joint front suspension with swept-back design. Permanently lubricated threaded bushing for upper suspension arms. 10-coil front springs. Full-cushion hydraulic shock absorbers. Rubber-mounted, linkless front torsional stabilizer bar.

REAR SUSPENSION: Splay-mounted leaf-type rear springs, 55-inches long. Compression-type rear shackles. Full-cushion shock absorbers.

STEERING: Ball and rack type gear. Steering shaft straddle-mounted. Over-all steering ratio 31.0 to 1 manual, 24.0 to 1 with optional power.

BRAKES: Internal expanding hydraulic-type. 11-inch brake drum. Brake shoe width—3 in. front, 2½ in. rear. Total braking area 233.4 sq. in. Independent mechanical parking brake. Step-on parking brake pedal. Self-adjusting brake linings.

BODY

DIMENSIONS: Wheelbase, 122 in. Over-all length 214.2 in. Over-all height 58.3 in. Over-all width 79.1 in.

STRUCTURE: Welded steel body. Convertible-type doors. Front-hinged hood. Combination bumper-grille. Double-panel door, hood, and deck lid construction. Safety door locks. Two-stop front doors. Dual headlamps. High-level outside air intakes on cowl. Retracting back window.

MAJOR OPTIONS*: Merc-O-Matic with Keyboard Control†, Power-Booster Fan, power steering, power brakes, automatic power seat, 4-way power seat, heater-defroster, heater-defroster-air conditioner, power-operated windows, power lubrication, tinted windows, nylon tires, whitewall tires, padded instrument panel†, padded sun visors, and seat belts, Air Cushion Ride, dual exhaust, Super Marauder V-8 engine. *Optional at extra cost.

†Standard in Voyager and Colony Park models. Mercury Division of Ford Motor Company, Dearborn, Michigan, reserves the right to discontinue or change, at any time, model specifications or design without incurring obligation.

STATION WAGON CATALOG M58-101

PRINTED IN U.S.A.

1958 MERCURY

SPORTS-CAR SPIRIT WITH LIMOUSINE RIDE