

hrysler '61 Chr

ysler '61 Chrysl

Chrysler '61 O

rysler '61 Chry

Featuring the new Newport—a full-size Chrysler in a new, lower price range



It looks like a million, but the Newport is the lowest priced member of the Chrysler family. Shown here, the two-door hardtop in Mardi Gras Red.

This is Chrysler '61. It comes in three series and thirteen models, including a completely new Newport series in a new, lower price range. There are no jr. editions. Every Chrysler is a full-size, grown-up car with real six-people room. Every Chrysler is a richly furnished, comfortable car. Every Chrysler is a powerful, yet economical car with a V-8 designed by engineers who have produced class winners in three of the last four Mobilgas Economy Runs. Every Chrysler features an alternator that charges your battery even at idle. And every Chrysler, including the new, lower priced Newport, is built the same solid way. Body and frame are joined in a strong, one-piece Unibody. The Unibody is immersed seven times in different chemicals and rinses to fight rust inside and out. Ninety-five pounds of sound deadener sop up annoying noise. And Chrysler's torsion-bar suspension grips the road with such assurance that even seasoned auto experts sit up and take notice. But why take our word for it? Test-drive Chrysler yourself. Your dealer has the keys.



The Chrysler Newport

Like your cars roomy? Rangy? Rugged? Like *big* cars (but hate big price tags)? Then this new kind of Chrysler is your kind of car. Compact? You bet it *isn't!* The new Chrysler Newport is a full-size car stretching 122 comfortable inches hub to hub. It's a full-powered car packing a lively 361 cubic-inch Firebolt V-8 engine that's tuned to run on regular gasoline. It's a complete new series of cars built to traditional Chrysler standards of quality. And the best news of all is its new, lower price.



It looks like a million
family. Shown here in

se series and thirteen
ditions. Every Chry
ortable car. Every C
class winners in th
your battery even
ay. Body and fram
chemicals and rinses
rysler's torsion-bar s
But why take our w

**NEWPORT
STANDARD
EQUIPMENT**

- *AstraDome Control Center* ▪ *High-Tower Driver's Seat* ▪ *Automatic Front Door Light* ▪ *Map Light* ▪ *Safety-Cushion Dash* ▪ *Directional Signals* ▪ *Cigarette Lighter* ▪ *Ash Tray Light* ▪ *Replaceable-element Air Cleaner* ▪ *Oil Filter* ▪ *Dual Headlamps*

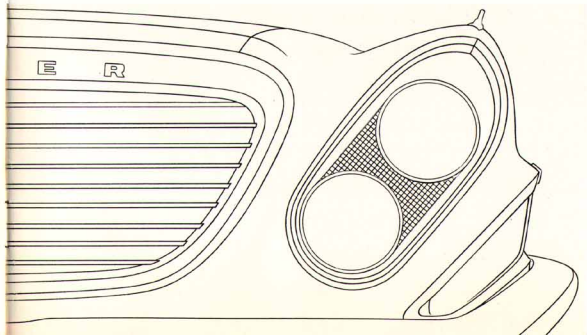

The Ch

Like your car is
price tags? The
Compact? You
car stretching 12
car packing a liv
to run on regul
traditional Chry
all is its new lo



New ribbed rear deck forms the happy ending of the Newport four-door hardtop, shown here in solid Sheffield Silver.



Room with a view, this Newport four-door sedan is a full-size car at a new, lower price. The Turquoise here is one of 12 colors and 28 two-tone combinations in the Chrysler rainbow.

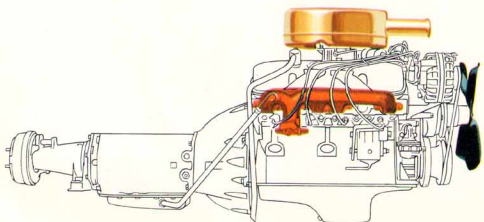

You get more miles per dollar with this new Firebolt engine, designed to deliver peak performance on *regular* gasoline. In many areas you can save as much as a dollar a tankful!

For even greater economy, a new floor-mounted manual transmission is offered as standard equipment. And the engine is cushioned on a coil spring for smoother, quieter operation.

No stripped-down, scaled-down jr. edition, the new Newport is sized, styled and built to the same standard of excellence as every Chrysler. Its solid, one-piece Unibody makes it stronger, tighter and roomier than conventional cars. It has the same AstraDome control center and shoulder-high driver's seat you'll find in every Chrysler. The only thing that's been lowered is the price!



Who'd think to see it, or sit in it or drive it, that the new Newport is the easiest-to-own Chrysler of them all. Feast your eyes on canted headlights, clean contours, tasteful trim—styled to stay in style. Slip inside and take your ease on five-foot-wide seats finished in long-wearing, double-woven fabrics. Take the wheel and see how torsion-bar suspension grips the road, smooths the bumps . . . how the new Firebolt V-8 engine loaf's at turnpike limits on *regular* gasoline! You save money when you buy the Newport. You save more money every mile you drive it! Can you afford less?



Clothe your Chrysler Newport in one of five different cloth and vinyl combinations. Each is color-keyed to an outside enamel. All are durable, beautiful. All-vinyl upholstery is standard on Newport convertibles and wagons, available at extra cost on Newport hardtops.

High-Tower driver's seat offers shoulder-high support, is standard equipment on every Chrysler. And as on all Chryslers, the height and angle of the front seat can be custom-positioned to your build.

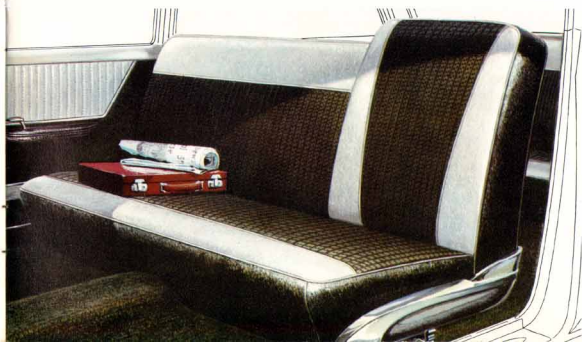

Who'd think to
is the easiest-to-
canted headlight
style. Slip inside
in long-wearing
how torsion-bus
... how the ne
regular gasoline!
save more mo

City smart, country strong, the new Newport Town & Country wagon is at home anywhere. This one's Capri Blue. How would you like yours?



The Chrysler Newport—priced within your reach



Two-way treat, this Sahara Sand Newport convertible is as spacious and snug as a hardtop with the top up. Top down, the sky's the limit on excitement.

Conventional cars have a frame . . . and a body that sits on the frame. Chrysler's Unibody combines the body and frame in a single, integrated unit.

What does all this mean to you?

Strength! In a body-frame car, the frame must compensate for lack of body strength, serves as a platform for needed rigidity and protection. Much of the metal used adds no

strength to the car. In a Unibody Chrysler the body, itself, provides the strength. Laboratory tests comparing Chrysler with a conventional body-frame car proved Chrysler 40% stronger, 100% more resistant to twisting. In fact, it's so strong that a Unibody Chrysler was driven from Chicago to Detroit on *three* wheels and still remained rattle-free.

Quietness! Body-frame cars use nuts and bolts in the body

which can squeak and rattle. Because Unibody is welded into a single piece, scientifically "tuned" to reduce vibrations, these noises can't occur. What's more, Chrysler blankets its cars with ninety-five pounds of sound-deadening material.

Roominess! Those fat frame members on conventional cars take up room. By eliminating them, Unibody allows lower floors, higher seats, more stretch-out comfort.

UNIQUE UNIBODY CONSTRUCTION MAKES CHRYSLER STRONGER, QUIETER, ROOMIER

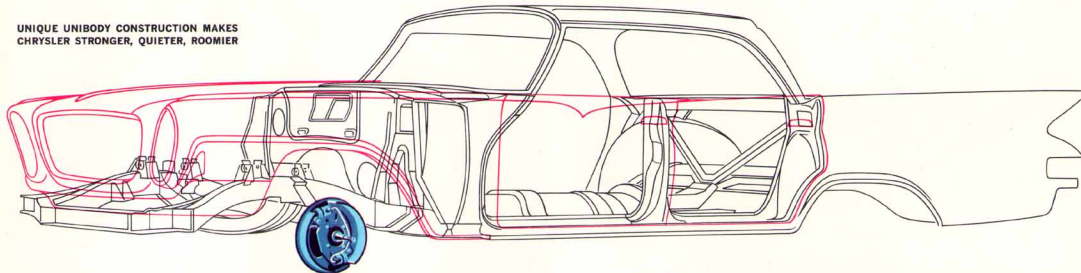

SEVEN DIPS SEAL OUT RUST

The rolled steel that goes into a Chrysler is scrubbed spotlessly clean before the car is stamped and assembled. Once Unibody is built, it's dipped seven times in rust-resistant chemicals and rinses. Every nook and cranny, outside and inside, is coated with a tough, protective shield that seals out rust for years and years.

SMOOTHER, SAFER RIDE

Chrysler's Torsion-Aire suspension uses straight, strong torsion bars in place of the usual front coil springs. Instead of bouncing up and down, they soak up bumps in a horizontal, twisting motion. You get a smoother ride and surer, safer steering. Auto experts applaud Torsion-Aire. You will, too.

BIGGER, BETTER BRAKES

The Total-Contact brakes on Chrysler are the biggest in its class with up to 351 sq. in. of area. Two cylinders in front brakes insure that all the lining grips the drum.

LONGER BATTERY LIFE

New alternator replaces generator, charges your battery even when engine is idling.

361
383 } CU.
413 } in.

MORE MILES FOR YOUR MONEY

The new 361 cu.-in. Newport V-8 runs on regular gasoline! The new 383 cu.-in. Windsor V-8 has an efficient 2-barrel carburetor. Both have short strokes for less wear. And the 413 cu.-in. V-8 in the New Yorker is the 1961 version of the one that won first in its class in last year's Mobilgas Economy Run.

HARDEST CAR FINISH KNOWN

Two coats of primer are baked on the car's outside surface and wet-sanded by hand to glossy smoothness. Then two coats of Lustre-Bond enamel are baked on top of the primer. Result: the hardest automotive finish known, a finish that stays looking showroom new without polishing or waxing.

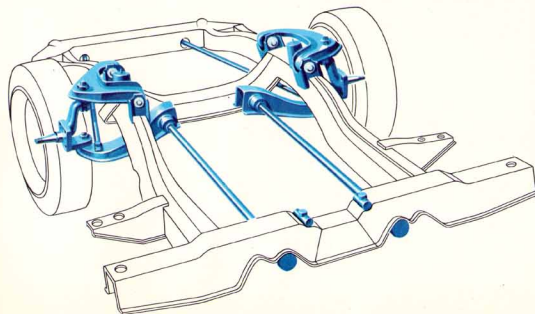

Every Chrysler is built from the bottom up to drive better and last longer. Constructed as a solid, single unit instead of a separate body and frame, Chrysler is far stronger and quieter than conventional cars. Dipped seven times in rust-resistant chemicals and rinses, it sports a tough protective shield against corrosion outside and in. Torsion bars instead of the usual front coil springs make Chrysler ride smoothly, steer safely. The brakes are bigger . . . feel surer . . . than the brakes on competitive cars. When you drive it, you'll know that Chrysler has no use for compromise, for "next-best" or "as-good-as." Do you?



Easy-going hardtop, the two-door Windsor is shown here in cool Capri Blue — one of 12 glistening colors to suit your fancy.



Green with envy is how your friends will feel when they see you in this Pinehurst Green Windsor sedan. Its Lustre-Bond enamel is the hardest automotive finish known.



Two-tone four-door, this Windsor hardtop in Tuscan Bronze is topped with Alaskan White — shows its true colors when you get in and go.

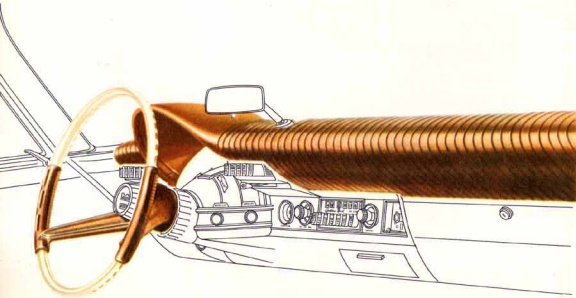

The AstraDome control center on every Chrysler places controls at your fingertips, makes instruments easy to read, adds immeasurably to driving safety.

Three-dimensional setting separates the gauges so you can see them at a glance. At night, soft Panelescent lighting bathes them in a soft, glare-free glow.

Pushbuttons at the left of the steering wheel control Chrysler's TorqueFlite auto-

matic transmission that glides from gear to gear so smoothly you don't even notice it. Handy pushbutton controls for the optional heater, air conditioner and radio are at the right.

The padded dash panel, extending the full width of the car, is standard on every Chrysler. And like the steering wheel, upholstery and trim, it's keyed to harmonize with exterior colors.

WINDSOR STANDARD EQUIPMENT

- Foam Rubber Seat Cushions
- Seat Side Shields
- Map Light
- Stainless Steel Wheel Covers
- Chrome Drip-Rail Molding
- Chrome Upper Door Covers (sedans only)
- AstraDome Control Center
- High-Tower Driver's Seat
- Safety-Cushion Dash
- Directional Signals
- Variable-Speed Windshield Wipers
- Cigarette Lighter
- Ash Tray Light
- Door-to-door Carpet
- Carpeted Luggage Compartment
- Replaceable-element Air Cleaner
- Oil Filter
- Dual Headlamps

The Chrysler Windsor

Who says a high-performance car can't be comfortable? Let the Windsor prove it can! You get every creature comfort—shoulder-high driver's seat, stretch-out room for six, designer fabrics, deep foam cushion, complete appointments. And you get them in a car that's born for driving. Three hundred and eighty-three cubic inches of engine swallow the miles without guzzling gas. Straight torsion bars in place of the usual front coil springs take the squat out of starts, the lean out of turns, the dive out of stops. You can have your comfort and drive it, too, if your car's a Windsor.



The Ch

Who says a high
Windsor prove
high driver's seat
foam cushion, ca
that's born for
inches of engine
torsion bars in p
out of starts, the
have your confi



Decorate your Windsor with vinyl bolsters, color-keyed to match the exterior, and pleated fabric cushions that complement the bolsters. The tan vinyl and brown fabric combination shown here is one of five available. You can also have red or white all-vinyl on hardtops at extra cost.

Door panels repeat the vinyl-fabric motif of the seats. Wide rear seat and low tunnel mean room for three to ride in comfort. Notice, too, how the front seat rises high behind the driver, supports him knee to shoulder.



The Ch

Who says a high Windsor prove a high driver's seat, a high foam cushion, a high that's born for inches of engine torsion bars in p out of starts, the have your confi



New Colors for the New Yorker include delicate Dubonnet, here gracing a two-door hardtop. Distinctive New Yorker grille is extruded aluminum.



Vinyl bolsters with nylon cushions are standard on New Yorker hardtops and wagons. Far left, gray and black. Center left, Dubonnet. At the near left, the all-vinyl trim: In red or white, it's standard on convertibles and extra cost on hardtops. In red or tan, it's standard on wagons. New Yorker sedans offer deep-nap wool broadcloth in solid blue (right) and gray (center). Or you can choose nylon fabrics set into broadcloth bolsters, such as the black and gray combination at the far right.

Black beauty, new razor-edge roof line and extra-large rear windows distinguish the New Yorker four-door hardtop.



Beauty marks, ten lustrous louvers identify the New Yorker. This is the four-door sedan, decked out in Parisian Blue.

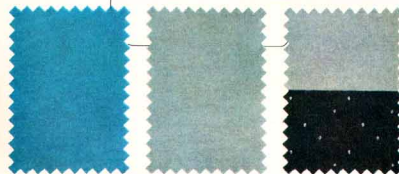
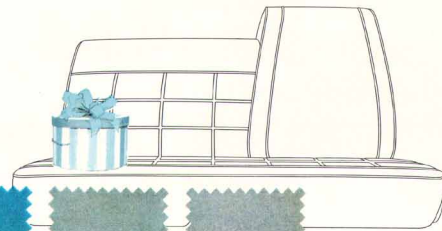

The Chrysler New Yorker

Sculpture in metal so faultless no chrome camouflage is needed. Sitting room on wheels that flatters you with the same fine fabrics, soft cushions and thick carpets you're used to at home. Thoughtful servant that pampers you with a pushbutton automatic transmission, power steering, power brakes and remote-control mirror. Working partner that combines every excellence known to automotive engineering to carry you quickly, quietly, effortlessly anywhere. Drive this New Yorker. Weigh it against any car you've known before. See for yourself why it's unquestionably Chrysler's finest.

Uninterrupted vision is the beautiful result of this New Yorker Town & Country's hard-top styling. Shown in Cinnamon, it's the most spacious, gracious wagon on the road.

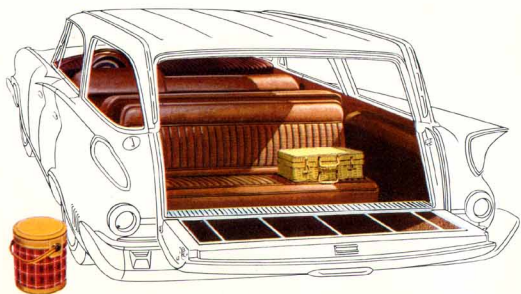

(Left) The rear-facing third seat in nine-passenger New Yorker wagons provides sedan-like leg room, folds quickly out of sight when not in use. (Choose scuffproof all-vinyl upholstery or vinyl with fabric material.) Ninety-five cubic-foot cargo capacity means you can take it with you. Deep-pile carpeting down the deck protects fine luggage. The rear window raises or lowers at the flick of a switch on the

instrument panel. And in six-passenger wagons, a locked luggage compartment hides valuables safely out of sight. (Right, under flap) Handsome vinyl upholstery, in a unique biscuit pattern, is standard equipment on the superb New Yorker convertibles. Interesting basket-weave texture permits the material to "breathe"—keeps you comfortably cool on the warmest top-down days.

The Chrysler New Yorker



Raise the roof in this Alaskan White New Yorker convertible. Top up, it's snug as a sedan.



Whether you're wearing a sports jacket or dinner jacket, you'll feel at home in one of these two New Yorkers. The Town & Country is the largest, most powerful wagon made. Yet it surrounds you with the thoroughbred beauty, comfort and convenience of a fine sedan. The convertible, too, is a dual personality, combining hard-top roominess and quietness and luxury with a top that opens or closes to match your mood. Either is one of the most satisfying cars a man can own—because it's so superbly made, because it's such sheer fun to drive.



**NEW YORKER
STANDARD
EQUIPMENT**

▪ Constant-Control Power Steering ▪ Total-Contact Power Brakes ▪ Pushbutton TorqueFlite Transmission ▪ Electric Clock ▪ Remote-Control Outside Mirror ▪ Tilt-type Inside Mirror ▪ Automatic Windshield Washer ▪ Folding Rear Center Arm Rest (sedan and four-door hardtop only) ▪ Foam Rubber Seat Cushions ▪ Seat Side Shields ▪ Back-up Lights ▪ Handbrake Warning Light ▪ Glove Box Light ▪ Luggage Compartment Light ▪ Automatic Front and Rear Door Light ▪ Map Light ▪ Sill Molding and Stone Shield ▪ Wheel Opening Molding ▪ Stainless Steel Wheel Covers ▪ Chrome Drip-Rail Molding ▪ Rear Bumper Guards ▪ Chrome Upper Door Covers (sedans only) ▪ Extra-large Shaded Rear Window (four-door hardtop only) ▪ Dual Exhausts (Town & Country only) ▪ AstraDome Control Center ▪ High-Tower Driver's Seat ▪ Safety-Cushion Dash ▪ Padded Steering Wheel ▪ Directional Signals ▪ Variable-Speed Windshield Wipers ▪ Front and Rear Cigarette Lighter (rear lighter on four-door models only) ▪ Ash Tray Light ▪ Door-to-door Carpet ▪ Carpeted Luggage Compartment ▪ Replaceable-element Air Cleaner



Whether you're at home in one is the largest, n with the thoro sedan. The con top roominess a closes to match cars a man can such sheer fun

1961 Chrysler Accessories

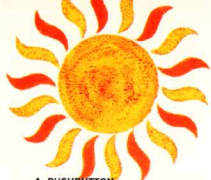

1. REMOTE-CONTROL OUTSIDE MIRROR

Move the control inside, and the mirror moves outside to suit your angle of vision. This accessory is especially convenient if more than one person drives your car. (Standard on New Yorkers.)

2. CONSTANT-CONTROL POWER STEERING

Works full-time to make driving and parking fingertip easy. Gives firm, accurate feel of the road. (Standard on New Yorkers.)

3. TILT-TYPE MIRROR

Lets you flick away dangerous headlight glare from cars coming up behind you. (Standard on New Yorkers.)

4. PUSHBUTTON AIR CONDITIONER

A touch sets the temperature. Changes air completely once a minute. Choose single or dual model with cooler in the back as well as the front of the car. (Single model not available on Town & Country wagons, dual model not available on convertibles.)

5. POWER DOOR LOCKS

Flick a switch and all four doors lock automatically for peace of mind when there are children aboard or the lady of the house drives alone.

6. ELECTRIC LOCK

Split-second accurate, completely quiet and dependable. (Standard on New Yorkers.)

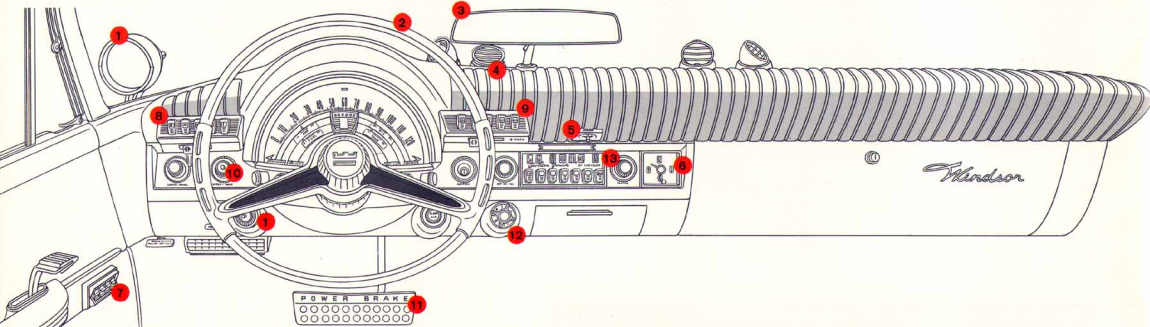

7. POWER WINDOWS

You can control all four windows electrically, from the driver's seat. Each passenger also has a control of his own.

8. PUSHBUTTON TRANSMISSION

Chrysler's TorqueFlite puts controls right at your fingertips. Works trigger-quick. Glides from gear to gear so easily you don't even know it. (Standard on New Yorkers.)

9. PUSHBUTTON HEATER

Takes you from cold to comfort in minutes. Accurate thermostat maintains the temperature you set.

10. PUSHBUTTON WINDSHIELD WASHER

Completely new, electrically operated for '61, this Chrysler option is a must for foul-weather driving. (Standard on New Yorkers.)

11. TOTAL-CONTACT POWER BRAKES

A touch of your toe and you come to a straight, smooth stop. Wide pedal lets you use your left foot. (Standard on New Yorkers.)

12. AUTOMATIC AUTO-PILOT

Lets you drive with your foot off the gas. Holds any speed you set until you touch the brake. Takes over again when car returns to set speed. Takes the dangerous tedium out of turnpike driving. Also serves as a reminder of speed limits.

13. PUSHBUTTON RADIO

A touch and you're tuned. Choose from two Chrysler transistor radios: The Golden Tone. Or the Golden Touch Tuner with foot-operated station changer. Both available with power antenna and rear-seat speaker.

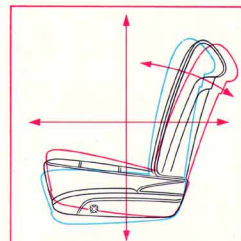
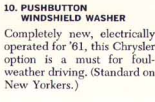
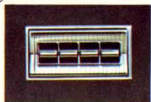

SIX-WAY POWER SEAT

Moves any direction you move the control at the base of the driver's seat. Changing position cuts fatigue on long trips. Wonderful when you take turns driving.

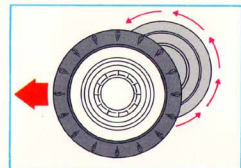

SURE-GRIP DIFFERENTIAL

Gives your Chrysler sure footing on snowy, icy, muddy or wet roads. Transfers power to the wheel getting the most traction, walks you right out of trouble. If you live or drive in the country, this Chrysler engineering feature is a must.



Specifications

ENGINE

Golden Lion V-8, 90-degree lateral. Bore and Stroke: Newport—4.12 x 3.38, 361 cubic inches; Windsor—4.25 x 3.38, 383 cubic inches; New Yorker—4.18 x 3.75, 413 cubic inches. Compression ratio: Newport—9.0 to 1; Windsor—10.0 to 1; New Yorker—10.1 to 1. Horsepower: Newport—265, Windsor—305; New Yorker—350.

TRANSMISSIONS

Pushbutton TorqueFlite, fully automatic torque converter with 3-speed gear set, standard on New Yorker, available on Newport and Windsor. Manual 3-speed transmission standard on Newport and Windsor.

SUSPENSION

Time-tested Torsion-Aire suspension, standard. Ball-joint pivots (front) with Orloff shock absorbers.

FUEL SYSTEM

Carburetors: dual downdraft on Newport and Windsor, four-barrel downdraft on New Yorker. Automatic intake manifold heat control, automatic choke, dual filtration units. Fuel capacity—23 gallons. 22 gallons for Town & Country Wagons.

ELECTRICAL SYSTEM

Battery: 12-volt, 66-plate, 60-amp-hr. on Newport and Windsor, 12-volt, 78-plate with 70-amp-hr. on New Yorker. Alternator: 35-amp, (40-amp, with air conditioner). Waterproof ignition. Electric windshield wipers and directional signals. Dual headlights, standard.

COOLING SYSTEM

Thermostatic by-pass control. Pressure vent radiator cap. Coolant capacity, 16 qts. on

Newport, Windsor, and New Yorker. Add one quart to heater-equipped models.

BRAKES

Total-Contact with Cycledbonded lining. Drum diameters: 12" on New Yorker and all Town & Country Wagons, 11" on Newport and Windsor. Power brakes standard on New Yorker; available at extra cost on Newport and Windsor models.

STEERING

Manual, worm and 3-tooth roller, standard on Newport and Windsor. Constant-Control power steering with quick 3½ turns lock-to-lock, standard on New Yorker, available on Newport and Windsor.

DRIVE

Hotchkiss drive through rear springs. Hypoid rear axle with 2.53 to 1 ratio with Torque-Flite, 3.23 to 1 with manual transmission.

WHEELS AND TIRES

Safety-Rim wheels. Standard tire sizes: Newport and Windsor—8.00 x 14, except Newport Town & Country Wagon, 8.50 x 14; New Yorker—8.50 x 14, except Town & Country Wagon, 9.00 x 14. White sidewall and Captive Air tires (wagons only) also available. Chrome stainless wheel covers standard on Windsor and New Yorker, optional on Newport.

DIMENSIONS

Wheelbase: Newport and Windsor—122", New Yorker—126". Over-all length: Newport and Windsor—215.6", New Yorker—219.8". Width: 79.4". Tread: Newport and Windsor—61.0" (front), 59.7" (rear); New Yorker—61.2" (front), 60.0" (rear).

All prices, specifications, equipment and colors subject to change without notice and without any obligation on cars already produced.

Chrysler '61 C

Chrysler '61 Chry

CHRYSLER '61...NEWPORT ■ WINDSOR ■ NEW YORKER ■ 300/G

Chrysler '61

Chrysler '61 Ch