



THE 1962 FORDS

GALAXIES • GALAXIE/500'S • GALAXIE 500/XL'S • STATION WAGONS

1962...A Brilliant Galaxie Year

If this is your year for a new car, by all means see and drive the new '62 Galaxie by Ford. Never before have Galaxies been so glamorous or so luxurious (two examples: the exhilarating Galaxie 500/XL's on these pages), or so numerous (14 models in all, including sedans, hardtops, convertibles, wagons). ☉ This year, more than ever before, Galaxie styling is the envy of the industry. Widely copied, too, are the service-saving features pioneered by Galaxie. Now Galaxie pioneers again with *Twice-a-Year Maintenance* . . . you go 6,000 miles between routine service stops. No other car in Galaxie's field offers you such a saving in time and service expense! ☉ The '62 performance story is all-Galaxie. Take your pick of five brilliant Thunderbird V-8's* that soar all the way up to 405 hp! (Your choice of five transmissions*—widest range in Galaxie's field!) And Galaxie quality is unsurpassed by *any* car. The ride is silent as a secret. ☉ In the 14 new Galaxies for '62 you'll find the model and price that's just right for you. Your Ford Dealer extends a warm invitation to stop in and take the Galaxie for a test drive. See him soon. This could well be *your* year for a Galaxie. And it's the *greatest* yet!

*Optional

Cover: Galaxie 500/XL Sunliner in Rangoon Red

Galaxie 500/XL Sunliner in Castilian Gold

Galaxie 500/XL Club Victoria in Viking Blue



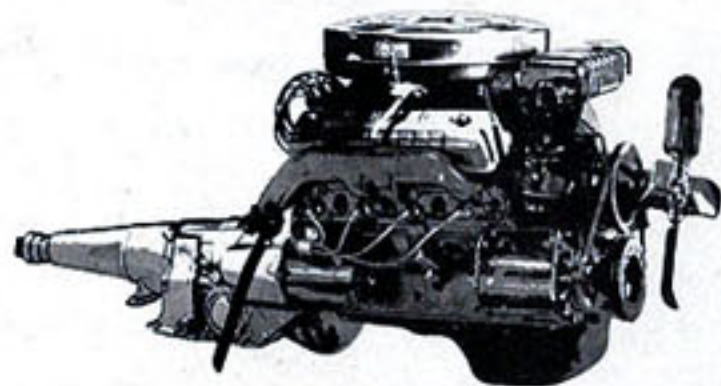

THUNDERBIRD 292 V-8



CONSOLE RANGE RADIO

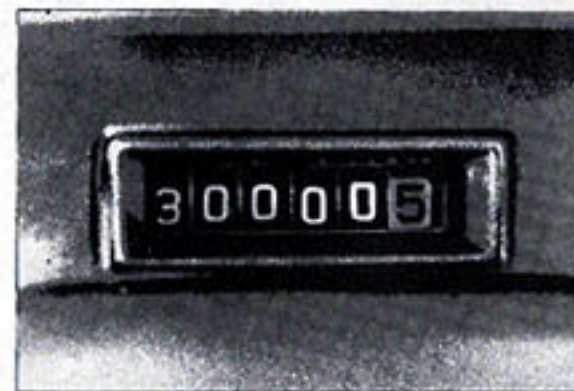

30,000 AND 6,000 — THE MAGIC FORD NUMBERS

Galaxie sedan and wagon owners enjoy a completely new kind of freedom from the time, trouble and expense of ordinary car service. It's Ford's exclusive twice-a-year (or 6,000-mile) maintenance. Like no other car in its class, the '62 Galaxie goes 30,000 miles between major lubrications . . . 6,000 miles between oil changes* and minor lubes. Moreover, in a '62 Galaxie you can go two years or 30,000 miles without draining engine coolant-antifreeze (and have anti-rust radiator protection, too!) Fuel filter goes 30,000 miles between changes . . . brakes are self-adjusting . . . muffler is fully aluminized for longer life. You'll save a lot on low Galaxie prices, but that's only where the savings begin!

*After first 1,000-mile change

GALAXIE SEDAN POPULAR OPTIONS

For Galaxie owners who want top economy, the standard Mileage Maker Six is recommended. Those who favor V-8 performance can select from the Thunderbird 292 or 352 Special (both regular gas V-8's), or the Thunderbird 390 Special. (Or for all-out GO up to 405 hp, any Galaxie sedan can be equipped with the Thunderbird 406 High-Performance or Super High-Performance V-8's. Your Ford Dealer has full details.) Transmissions available with most engines include 2-speed Fordomatic, dual-range Cruise-O-Matic, Overdrive and 4-Speed Manual (required with 406 V-8's.) (MagicAire Heater* is now included in the price of every Galaxie.) Console Range Radio is one option nearly all owners ask for. (For all '62 options and accessories, see pages 26-29.)

*Heater is installed during production unless otherwise specified. If deleted, an appropriate price reduction is made.

GALAXIE SEDAN STANDARD EQUIPMENT

Choice of Six Distinctive Vinyl and Nylon Cloth Interiors * Choice of 12 Diamond Lustre Enamel Exteriors * Color-Keyed, Wall-to-Wall Carpeting * White Vinyl Headlining * Bright-Metal Side Window Frames * Cigarette Lighter * Wide-Vision, Double-Swivel Safety Rearview Mirror * Dual Sun Visors (with retention clips) * Front and Rear Arm Rests and Ash Trays * Foam-Cushioned Front Seat with Automatic Posture Control * Color-Keyed Lifeguard Steering Wheel with Chrome Horn Ring * Dome Light Controlled by Front Door Courtesy Switches and Main Light Switch * Step-On Parking Brake with Instrument Panel Control Knob Release * Front Seat Belt Anchors * Illuminated Luggage Compartment * Mileage Maker Six Engine * Three-Speed Manual Transmission * Self-Adjusting Brakes * Single-Speed Electric Windshield Wipers * Full-Flow Oil Filter * Fully Aluminized Muffler * 30,000-Mile Fuel Filter * Center-Fill Fueling



Without question the '62 Galaxie Club and Town Sedans are luxury cars. They are as lavish in comfort, convenience and appointments as competitive cars costing hundreds of dollars more. Yet, they are actually lowest in price of all '62 Galaxie Series! * Galaxies are luxury cars in everything but price. Compare the Galaxie sedan standard equipment features listed on the opposite page.

Compare the rich vinyl and nylon cloth trim (two-tone beige interior at left is one of six choices). * Compare these cars critically with any other more expensive cars you choose. The biggest difference will be what you can save with a Galaxie.

Galaxie Club Sedan in Sandshell Beige (offered also in 4-door Town Sedan model)



GALAXIE SEDANS

Without Question a Luxury Car...in Everything But Price



CRUISE-O-MATIC

POWER STEERING

POWER BRAKES

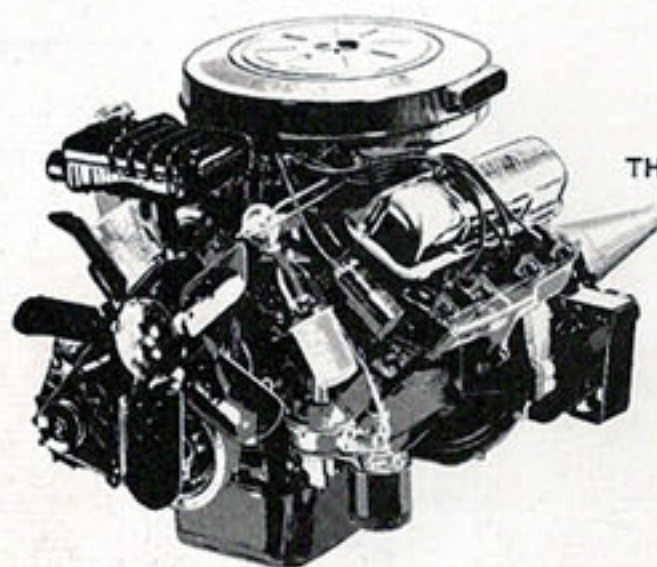

THUNDERBIRD 352 SPECIAL V-8

GALAXIE/500 SEDAN POPULAR OPTIONS

When buyers step up to the luxury of the new Galaxie/500 Series, they can "step up" their power, too. Many will find Ford's Thunderbird 352 Special V-8 to their liking for the spirited way it GOES on regular gas. Or they can choose the ultrasensitive Thunderbird 390 Special V-8. (Top engine options are the lusty "406" High-Performance V-8's . . . up to 405 hpl They're available in all '62 models except wagons. Ask your Ford Dealer about them.) Versatile dual-range Cruise-O-Matic rates high as the transmission choice. Power Steering and Power Brakes plus All-Vinyl Interior Trim in five color choices add comfort, convenience and distinction. For many other worthwhile options, see pgs. 26-29.

Galaxie says Quality...and says it in a Whisper

BODY INSULATION AND RUSTPROOFING

Galaxie sedans and wagons ride "silent as a secret." By every practical means known to automotive engineering, noise, vibration and ride harshness have been "tuned out" of '62 Galaxies. Frame members have been newly designed . . . new body insulations developed . . . to more effectively isolate the passenger compartment. And underneath, body rocker panels are zinc-coated against rust and corrosion.

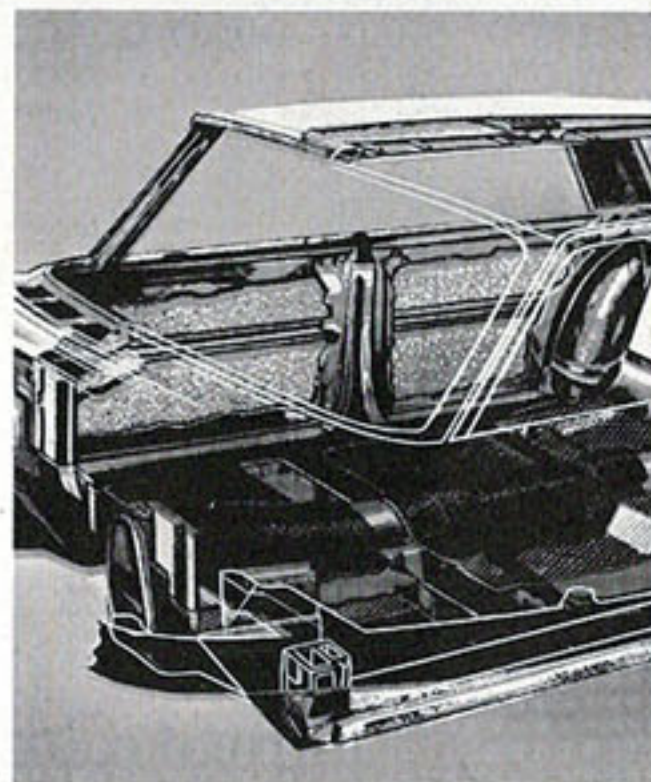

GALAXIE/500 SEDAN STANDARD EQUIPMENT

Additional luxury items over and above Galaxie equipment listed on page 4:

- * Choice of Seven Distinctive Vinyl and Nylon-Plastic Fabric Interiors
- * Choice of 13 Diamond Lustre Enamel Exteriors
- * Richly Pleated Seat Fabrics, Door and Side Trim Panels, Highlighted with Sparkling Chrome-like Mylar
- * Deluxe Arm Rests, Front and Rear
- * Self-Regulating Electric Clock
- * Backup Lights (centered in taillights)
- * Bright-Metal Drip Rail on Roof
- * Bright-Metal Ford Crest on Rear Roof Quarter
- * Bright-Metal Fender Ornaments
- * Attractive Bright-Metal Body Side Molding with Complementary-Colored Insert
- * Distinctive Grille-Styled Bright-Metal Panel at Rear
- * Bright-Metal Rear Fender, Front and Rear Wheel Openings and Rocker Panel Moldings

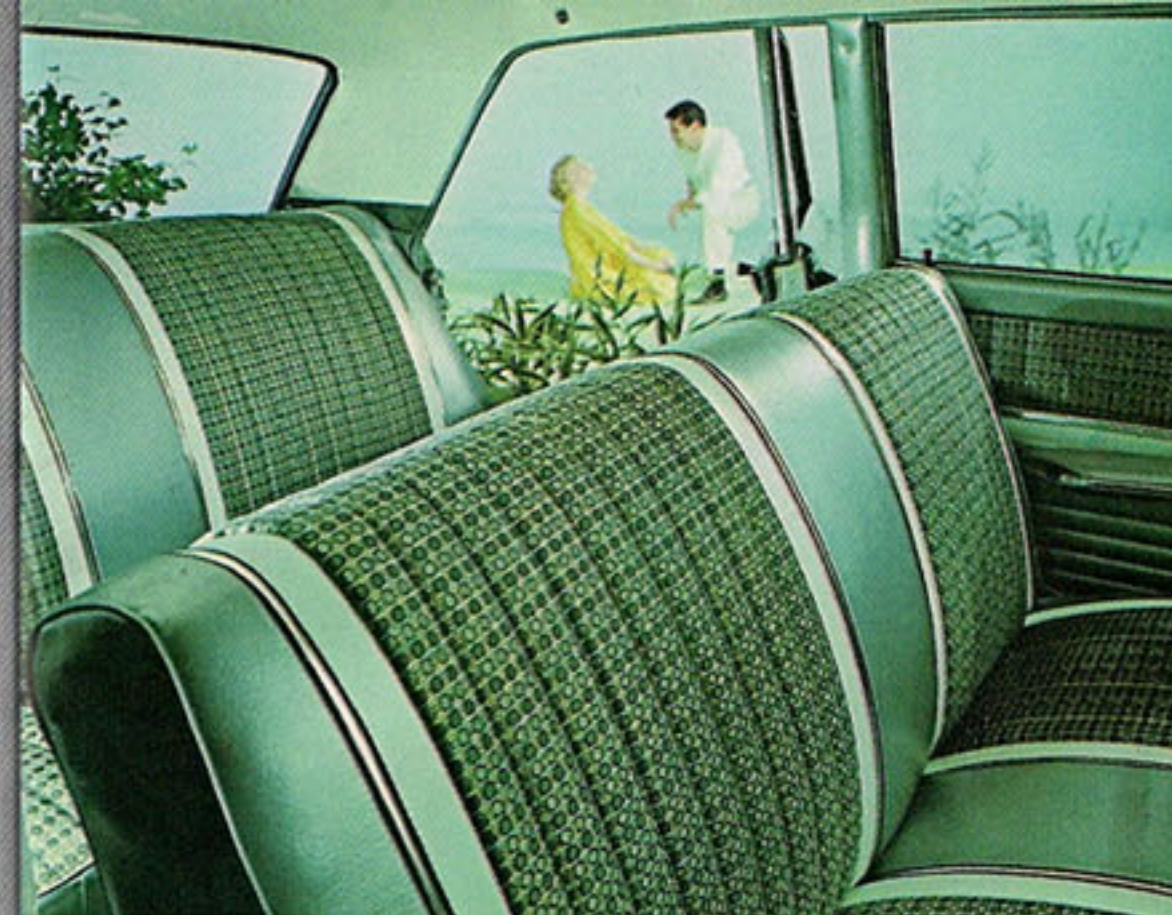

GALAXIE/500 SEDANS — Slide in under the wheel of the brilliant new Galaxie/500 by Ford. The upholstery is tailored of deep-pleated nylon-plastic fabrics and leather-grained vinyls (green shown, one of seven standard choices). The seat is cushioned in foam . . . comfort-high, posture-perfect. Even with a full complement of six big people, there's room aplenty for heads and shoulders, hips and legs. — Over the road, Galaxie/500 carries you more insulated from vibration . . . more isolated from sound than you would ever imagine of a car in its price range. This is Galaxie speaking quietly of its quality.

Galaxie/500 Town Sedan in Silver Moss (offered in 2-door Club Sedan model also)





GALAXIE/500 CLUB VICTORIA

The '62 Galaxie/500 Club Victoria dramatically mirrors an illustrious Thunderbird heritage in its looks, luxury and spirit. You've seen "pretenders," of course, by the dozen . . . those who flatter by following this glamorous Galaxie 2-door hardtop. And, you'll see more. But they can only hope to *look* like Galaxie. There's *never* an equal to a genuine original . . . and so it is with Galaxie. The reasons why are these: *Thunderbird Elegance* . . . the unique combination of styling perfection, interior richness and quality throughout. *Thunderbird Performance* . . . that spirited, lean-muscle brand of action that comes only from a Thunderbird V-8, by the master maker of V-8's, Ford.



GALAXIE/500 CLUB VICTORIA POPULAR OPTIONS

Adding spirited performance to hardtop individuality, Galaxie/500 Club Victoria buyers can choose the Thunderbird's own 390 Special V-8 (identified by its distinctive "390" fender emblem) or the regular gas Thunderbird 292 and 352 Special V-8's. (You can also have one of the mighty "406" High-Performance V-8's in your Victoria. Consult your Ford Dealer.) Dual-range Cruise-O-Matic, Overdrive, and 4-Speed Manual, available with most engines, offer a transmission choice to fit almost any kind of driving. Power Windows and Power Seat are appreciated for their added convenience. You can choose from five All-Vinyl Interior Trims for added luxury. PolarAire Conditioner, Ford's moderately priced answer to heat and humidity, is highly favored wherever summer temperatures soar. Always popular are Ford's Safety Package (lifeguard padded dash and visors) and Seat Belts. Consult pages 26-29 for other options you'll want to consider.

GALAXIE/500 CLUB VICTORIA STANDARD EQUIPMENT

Additional luxury items over and above Galaxie equipment listed on page 4:

- * Distinguished Hardtop Styling
- * Choice of Seven Distinctive Vinyl and Nylon-Plastic Fabric Interiors
- * Choice of 13 Diamond Lustre Enamel Exteriors
- * Richly Pleated Seat Fabrics, Door and Side Trim Panels, Highlighted with Sparkling Chrome-like Mylar
- * Deluxe Arm Rests, Front and Rear
- * Self-Regulating Electric Clock
- * Chrome-Backed Rearview Mirror
- * Backup Lights (centered in taillights)
- * Bright-Metal Drip Rail on Roof
- * Bright-Metal Ford Crest on Rear Roof Quarter
- * Bright-Metal Fender Ornaments
- * Attractive Bright-Metal Body Side Molding with Complementary-Colored Insert
- * Distinctive Grille-Styled Bright-Metal Panel at Rear
- * Bright-Metal Rear Fender, Front and Rear Wheel Openings and Rocker Panel Moldings

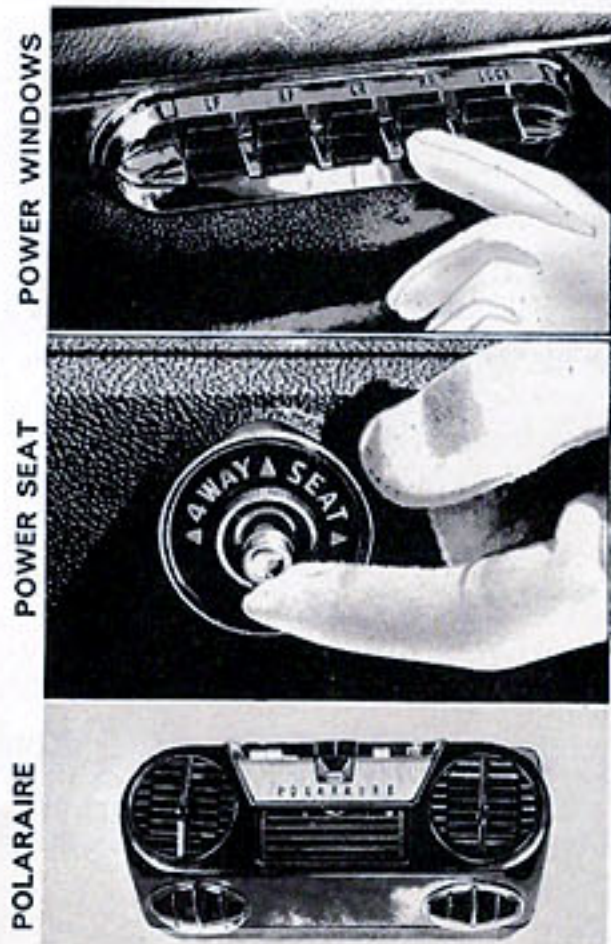

POSTURE-PERFECT SEATS

You get the feel of Ford's fine-car quality just sitting in the seats. Seat backs are angled at a Posture-Perfect 23°. There is firm yet gently cushioned support across your shoulders and back . . . under knees and thighs. Ride for miles or days in a Galaxie and you'll ride and arrive less tired, more relaxed.

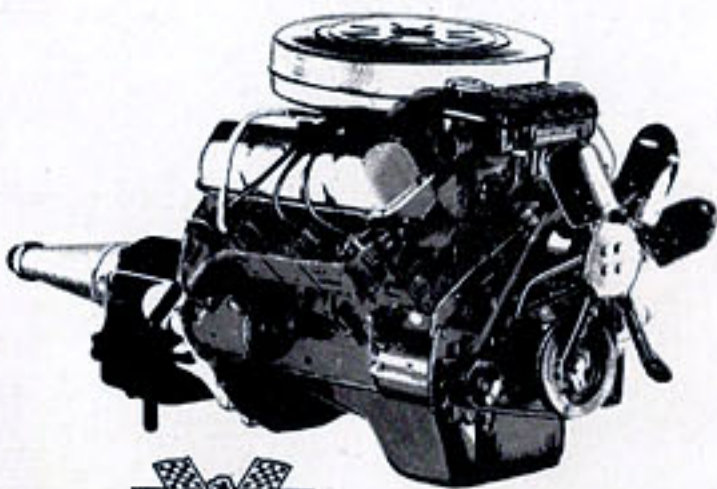

THUNDERBIRD 390 SPECIAL V-8

Enduring Elegance...with the Power to Please



THUNDERBIRD 390 SPECIAL V-8

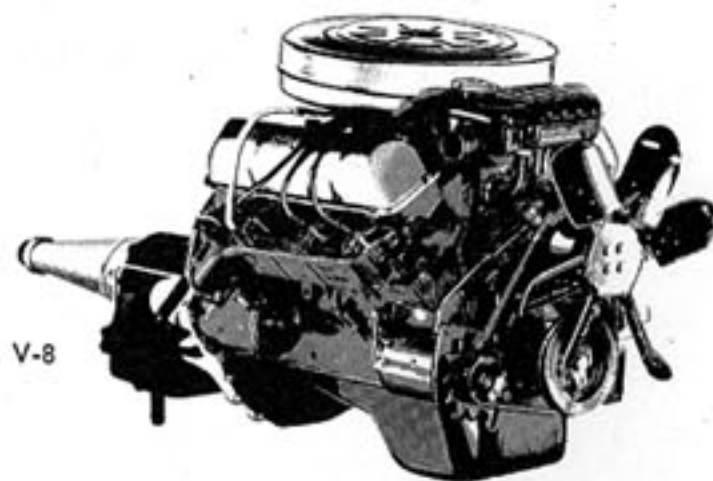

GALAXIE/500 TOWN VICTORIA STD. EQUIP.

Additional luxury items over and above Galaxie equipment listed on page 4:

- * Distinguished 4-Door Hardtop Styling
- * Choice of Seven Interiors and 13 Exterior Colors
- * Richly Pleated Seat Fabrics, Door and Side Trim Panels, Highlighted with Sparkling Chrome-like Mylar
- * Deluxe Arm Rests, Front and Rear
- * Self-Regulating Electric Clock
- * Backup Lights
- * Exterior Bright-Metal Trim Same as Listed for Club Victoria on page 8.

GALAXIE/500 TOWN VICTORIA OPTIONS

Town Victoria buyers will find the 300-hp Thunderbird 390 Special is an excellent V-8 choice for all-round driving. Top performers are the 406 High-Performance and Super High-Performance V-8's (your Ford Dealer has complete details). Or, if you want V-8 pep on regular gas, the Thunderbird 292 or 352 Special will merit first consideration. Ford Overdrive is the top gas economy transmission (available with all except "406" V-8's). Console Range Radio is just about a unanimous choice, and PolarAire Conditioner or SelectAire Conditioner is sure to be appreciated in warm weather.

OVERDRIVE



CONSOLE RANGE RADIO

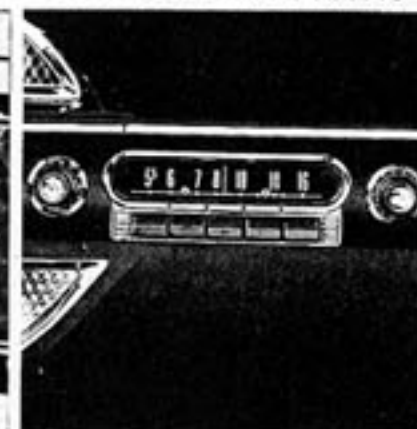

POLARAIRE

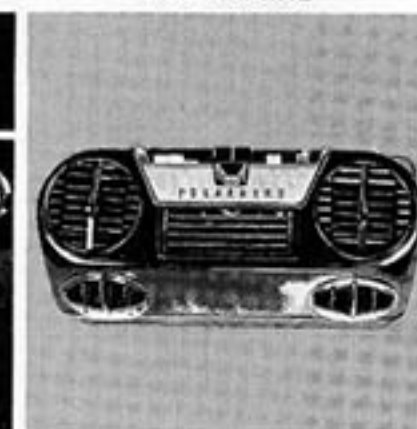

It's Quality is a Matter of Extra Care, not Extra Cost



ILLUMINATED TRUNK

Just one of literally dozens of extra-convenience features which Galaxie owners get as standard equipment is an illuminated trunk. Galaxie's big round taillights provide this illumination—clear, white light shining from either side of the trunk—in addition to their primary safety-signaling function. Adding more convenience, Galaxie gives you the widest trunk opening (5 feet wide) in its field!

GALAXIE/500 TOWN VICTORIA ☺ As striking and pleasing as the styling of this 4-door hardtop is the quality that has been built into the car. And the same is true of any '62 Galaxie or Galaxie/500 . . . sedan or wagon. ☺ Galaxie quality is a matter of extra care and attention to the details. Wherever you look in a Galaxie you see quality. But it's most apparent when you get behind the wheel. You can sense the finer way in which this car has been built by its quiet ride . . . by the smooth precision of its handling . . . the fleetness of its acceleration . . . the sureness of its braking. ☺ Of course you *can* pay more for fine-car quality, but Galaxie price tags make it *quite* unnecessary!

Galaxie/500 Town Victoria in Corinthian White



GALAXIE/500 SUNLINER POPULAR OPTIONS

Sunliner owners with a preference for performance can specify the Thunderbird 390 Special V-8 (identified by its "390" fender emblem) and dual-range Cruise-O-Matic. For performance par excellence, there are the "406" High-Performance V-8's... with up to 405 hpl New 4-Speed Manual Transmission has sports car fun built in (required with 406 V-8's). Most any Sunliner owner would favor the added convenience of Power Steering and Power Brakes, Power Seat (except with 4-Speed Manual Transmission) and Power Windows. See pages 26-29 for additional options.



CRUISE-O-MATIC

POWER STEERING

4-SPEED MANUAL

GALAXIE/500 SUNLINER STANDARD EQUIPMENT

Additional luxury items over and above Galaxie and Galaxie/500 sedan equipment listed on pages 4 & 6:

- * Choice of Six Distinctive Pleated All-Vinyl Interiors
- * Vinyl-Bonded Retractable Top in Color Choice of White or Black
- * Anti-Ballooning Top Design: Top Fabric Sturdily Secured to Each Roof Bow
- * Zip-Out, 1,098-sq. in. Vinyl-Plastic Rear Window
- * Top Boot Color-Keyed to Interior
- * Automatic Courtesy Light under Instrument Panel

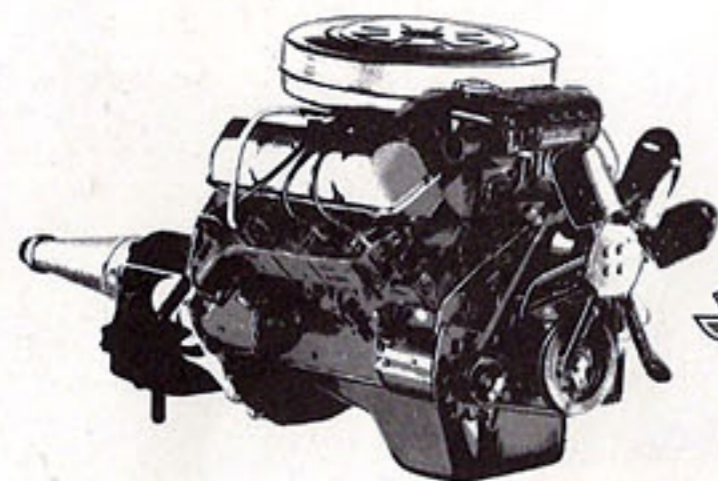

THUNDERBIRD 390 SPECIAL V-8

The Convertible that Puts Others in the Shade

4-SPEED MANUAL SHIFT... Ford offers you the widest choice of transmissions—five in all—of any American car! And of the five, this one is made to order for performance fans. Start-up ratio 2.36; forward gears fully synchronized for slick shifting up or down. Available with all except Six and 292 V-8.

SELF-ADJUSTING BRAKES

Here's additional freedom from service when you make your new car a Ford. Brakes on Galaxie sedans and wagons are adjusted automatically, for the life of the linings, when they are applied as the car is backing up. Naturally, adjustment occurs only when necessary.



GALAXIE/500 SUNLINER



Galaxie/500 Sunliner in Chestnut

This is the latest version of America's all-time favorite convertible. The rich chestnut all-vinyl interior pictured at right (one of six choices) is just a hint of how Sunliner shades rival convertibles in luxury. * And in quality? Sunliner's top is anchored at each roof bow to prevent "ballooning" under way. Top stows neat and trim under its color-keyed boot. This thorough-going quality is characteristic of the entire car. * And performance? Here's where Sunliner really leaves the others under a cloud. Powered by the Thunderbird's own "390" V-8* (or one of the "406" High-Performance V-8's*), Sunliner moves with a nimbleness and flight-like quality rivaled by only one other (and that's a "relative")—the Thunderbird itself!

*optional

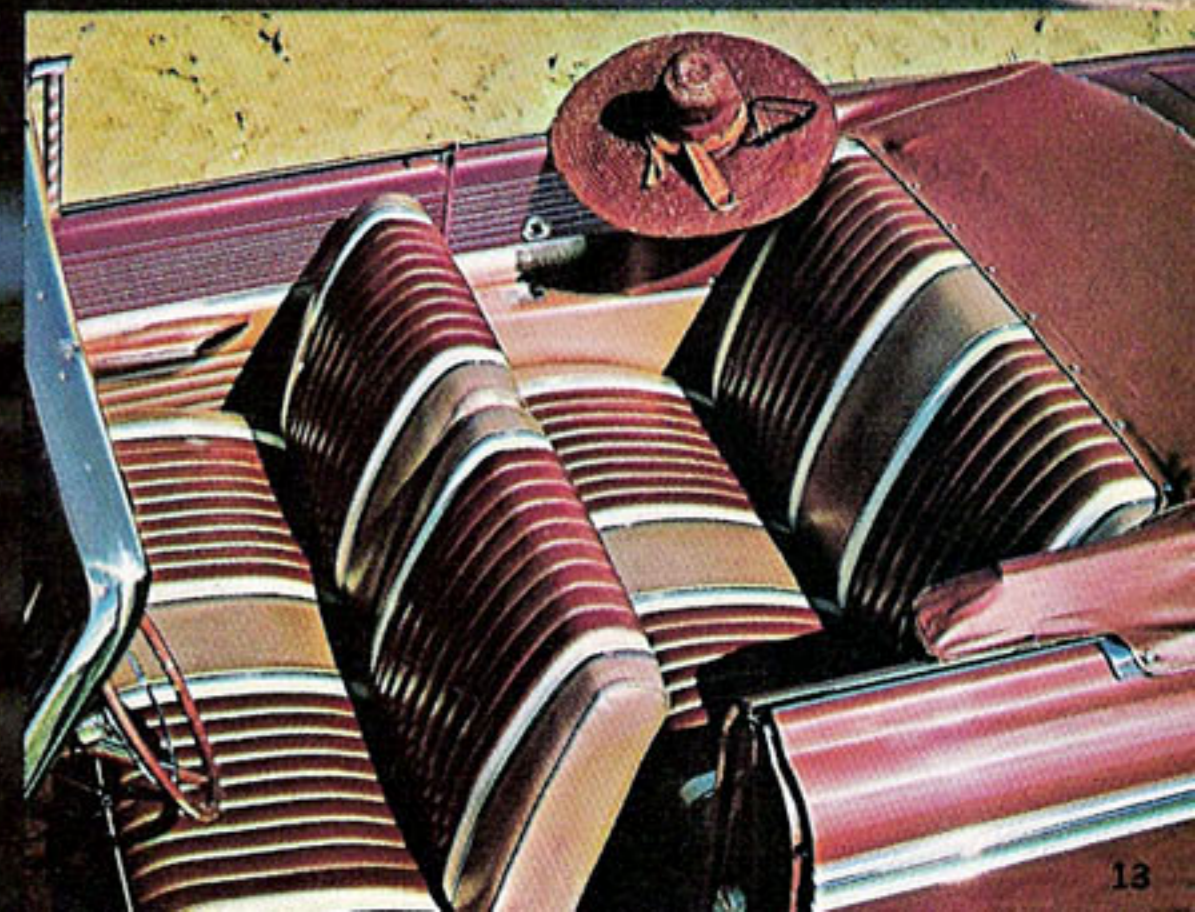

POWER STEERING

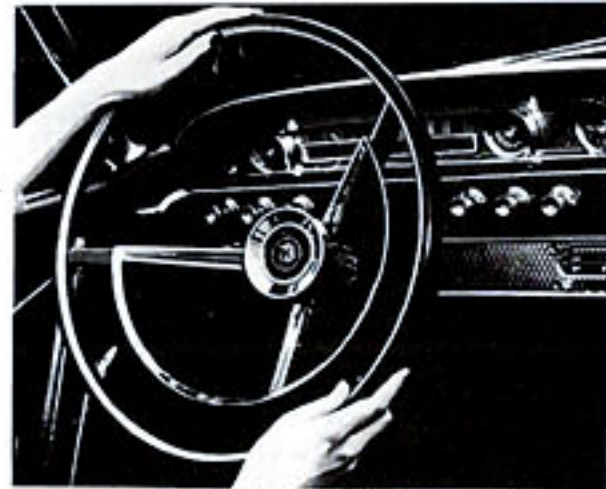

SELECTAIRE

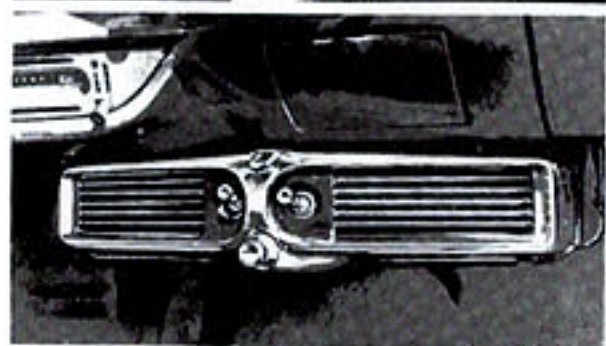

4-SPEED MANUAL



GALAXIE 500/XL OPTIONS

Power Steering,* Power Brakes* and Power Driver's Seat rate top consideration for their extra convenience, as does SelectAire Conditioner* for its extra comfort. XL owners can choose from four lively Thunderbird V-8's in addition to the standard Thunderbird 292: 406 Super High-Performance V-8 with 405 hp and 406 High-Performance V-8 with 385 hp (both identified by gold "406" fender emblems); Thunderbird 390 Special with 300 hp and the Thunderbird 352, a regular gas V-8, with 220 hp. Available with all of these four (and required with 406 V-8's) is the XL's 4-Speed Manual Transmission with console-mounted sports stick shift. Sports buffs can also specify Tachometer (registering up to 8,000 RPM) with any engine, and Power Pipes (muffler bypass type) with 406 V-8's.

*Available with all except 406 V-8's

GALAXIE 500/XL STD. EQUIP.

Includes every luxury feature listed for Galaxies and Galaxie/500's (pages 4 & 6) plus the following which are unique to 500/XL's...

- * Front Bucket Seats 100% Foam-Cushioned, Individually Adjustable
- * Full-Length Command Console Between the Seats
- * "Bucket-Styled" Rear Seat, Individually Contoured, 100% Foam-Cushioned
- * Choice of Seven Pleated All-Vinyl Interior Trims
- * Seats, Door and Side Trim Panels Accented with Chrome-like Mylar
- * Color-Keyed Carpet Runs Wall to Wall, Extends into Door Panels
- * Courtesy-Safety Light Cluster Mounted in Each Door
- * Power Team: Thunderbird 292 V-8 Engine, Dual-Range Cruise-O-Matic Drive with Console-Mounted "Sports Stick"
- * Color-Keyed Instrument Panel with Full-Chromed Controls
- * Super Deluxe Arm Rests, Front and Rear
- * Bright Metal-Accented Accelerator and Brake Pedals

Meet the brand-new, grand-new XL Club Victoria . . . Ford's liveliest hardtop to date! Luxury with a sports car lilt is the theme: front bucket seats elegantly pleated . . . foam-cushioned seat backs and cushions cradle you in comfort. (Rear seat duplicates the bucket design right down to the last pleat!) Rich trim materials are glove-soft vinyls, set off with sparkling accents of chrome-like mylar. Full carpeting . . . super Deluxe appointments . . . exclu-

sive courtesy-safety light in each door . . . "500/XL" insignia in jewel-like settings. Between the seats nestles the full-length XL command console with a personal storage compartment for milady's handbag or what-have-you. Under all the beauty this one's a true-blue Galaxie, dedicated to saving you time, trouble and money on service. For, like all Galaxies, XL's feature Ford's twice-a-year maintenance—they go 6,000 miles between routine service stops!

500/XL...passport to the Lively Life

500/XL INSTRUMENT PANEL

Galaxie 500/XL's are one-of-their-kind luxury cars, as the elegant XL instrument panel reveals.

All control knobs are richly chrome-finished. On the glove compartment door a "500/XL" medallion glistens in a jewel-like setting. Even the XL steering wheel and horn ring hub tastefully reflect the perfect blend of high style and complete function.

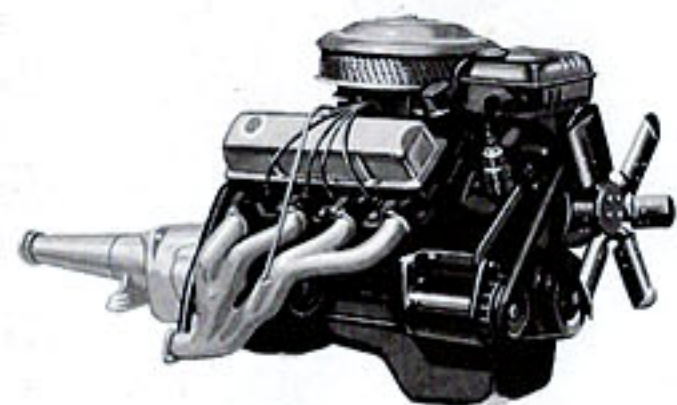
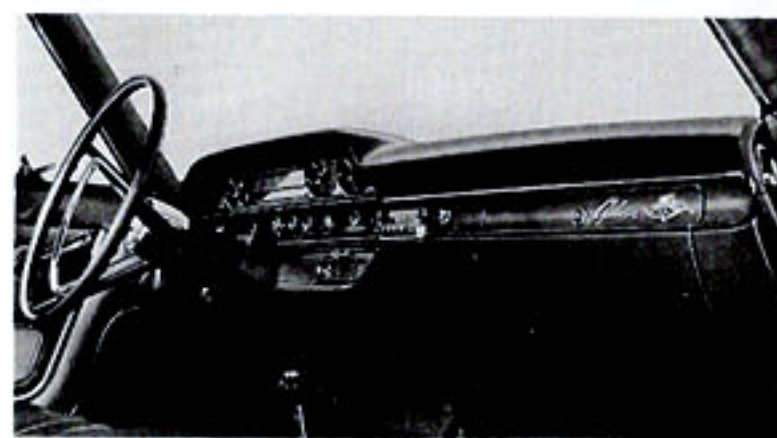

THUNDERBIRD 406 HIGH-PERFORMANCE V-8

Galaxie 500/XL club victoria in Ming Green



welcome to the Lap of Luxury

Behold the bucket-seat beauty of the 500/XL Sunliner! (If you favor the XL Club Victoria, simply add a steel top.) Cast your eye over the richly tailored seats . . . trimmed in glove-soft vinyl . . . deep-pleated for extra comfort. (Those extra-deep pleats are particularly appreciated in warm weather driving, as all convertible owners know.) Full carpeting . . . chrome-like mylar piping in seats and side trim . . . sculptured chrome seat side shields . . .

**Optional*

unique carpet-trimmed doors . . . elegance everywhere! Under the young lady's left hand is the command console, sweeping from under the instrument panel back between the front seats. High style and all-function, the console mounts controls for transmission and power windows,* and a surprisingly large covered storage compartment, big enough for your camera or even the favorite doll of the pretty little model in the front seat.



XL cockpit . . . functional as a sports car, comfortable as your favorite chair. Slip over behind the wheel and let the fun begin! And this XL, with its 4-speed manual stick shift,* would quickly win the heart of any performance fan.



Command console close-up. Standard Cruise-O-Matic Drive has "sports stick" control for sports car flair and extra convenience. Console is richly finished in ribbed bright metal (forward), and color-keyed vinyl (rear).



A unique XL feature is the courtesy-safety light cluster mounted in each door. Opening door automatically switches on light. It sends a clear, white beam into the car and a red warning beam to approaching traffic at rear.

Galaxie 500/XL interior of vibrant red vinyl, one of seven XL all-vinyl trim colors



GALAXIE 500/XL SUNLINER POPULAR OPTIONS

Ford options add greatly to enjoyment of the lively life in an XL convertible. For with selected options, each XL buyer can tailor his car exactly to his own personal needs. Here are some suggestions. Power Driver's Seat, Power Brakes* and Power Steering* are widely favored convenience options. Performance and Thunderbird V-8 power come as lively as you like. Choose the Thunderbird 352 or 390 Special V-8's with 220 hp and 300 hp, or go to the "big dazzlers," the 406 High-Performance or Super High-Performance V-8's with 385 hp and 405 hp! Manual 4-Speed Transmission available with Special V-8's, required on 406 V-8's.

*Available with all except 406 V-8's

GALAXIE 500/XL SUNLINER STANDARD EQUIPMENT

Includes every luxury feature listed for Galaxies and Galaxie/500's (pages 4 & 6) plus the following which are unique to 500/XL's . . .

- * Vinyl-Bonded Top in Choice of Black or White; Color-Keyed Boot with Concealed Fasteners and Padding
- * Foam-Cushioned (100%) Front Bucket Seats, Individually Adjustable
- * Full-Length Command Console
- * Foam-Cushioned (100%), "Bucket-Styled" Rear Seat
- * Choice of Seven Pleated All-Vinyl Interior Trims
- * Seats, Door and Side Trim Panels Accented with Chrome-like Mylar
- * Color-Keyed Carpet Runs Wall to Wall, Extends into Door Panels
- * Courtesy-Safety Light Cluster Mounted in Each Door
- * Power Team: Thunderbird 292 V-8 Engine, Dual-Range Cruise-O-Matic Drive with Console-Mounted "Sports Stick"
- * (All remaining items listed on page 14.)

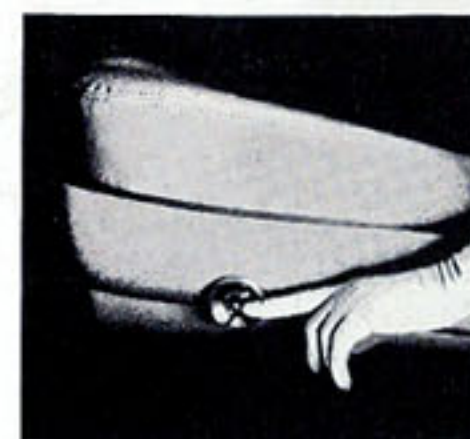

POWER SEAT

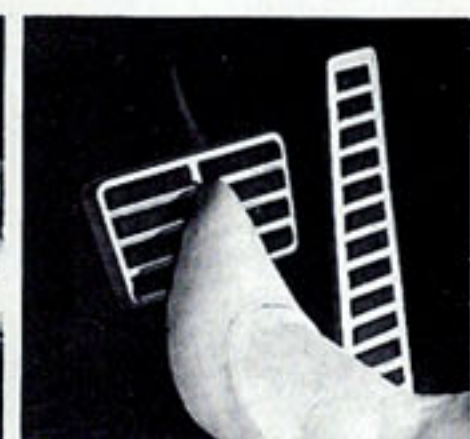

POWER BRAKES



POWER STEERING

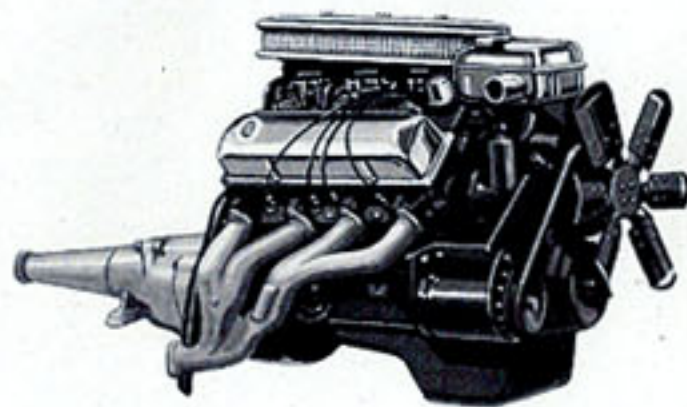

THUNDERBIRD 406 SUPER HIGH-PERFORMANCE V-8

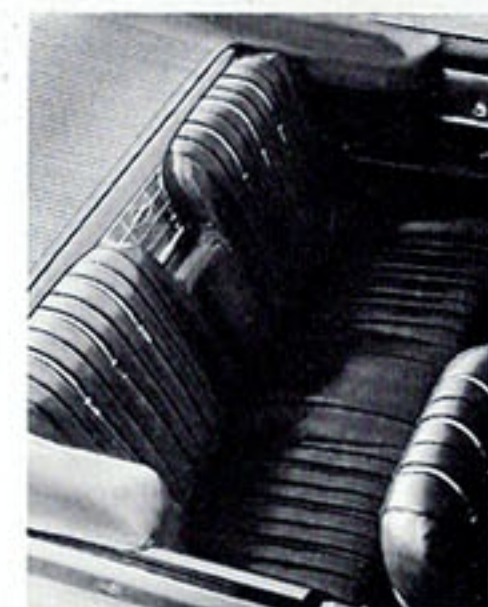

500/XL REAR SEAT STYLING

Look once and it almost seems there are buckets in back too. Look twice and you know where that deep-pleated rear seat bucket styling came from—straight from Thunderbird itself! The individually contoured design plus 100% foam-padded seat cushions and backs plus the deep pleats all add up to unsurpassed comfort. What's more, the XL rear compartment seat, adding even more comfort, is a full 3-passenger seat!

500/XL...Action in big V-8 helpings



Galaxie 500/XL sunliner in Rangoon Red

The only convertible that could outshine the Sunliner would have to come from Ford . . . and be a pretty special kind of convertible at that. The 500/XL Sunliner is *all* of that. ☺ A sports convertible counterpart of the XL hardtop, this one goes all the way in luxury, too—bucket front seats, "bucket-styled" rear seat . . . full-length command console . . . plus a sleek, trim, padded top boot that shows not so much as one fastener when the top is

*Optional

down. ☺ But make no mistake—the XL Sunliner mixes fire with all this finery. Up forward in the console is the action end of the business . . . a "sports stick" for Cruise-O-Matic, or 4-Speed Manual.* Thunderbird V-8 power choice soars all the way up to 405,* if that's your pleasure! If you like to live it up in convertible style, point this lively one at the nearest turnpike—and hang onto your hat!

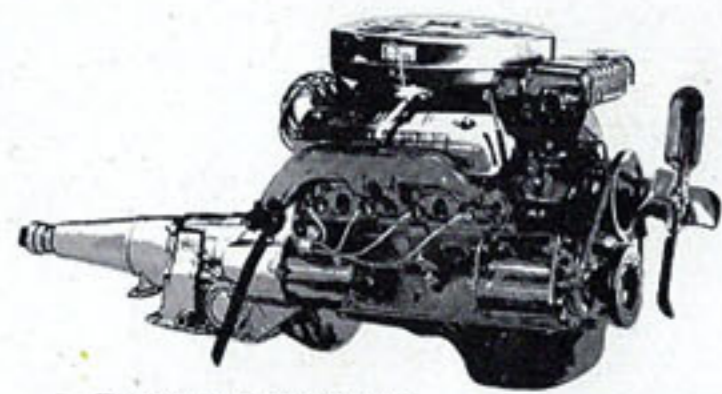

THUNDERBIRD 292 V-8

POWER TAILGATE WINDOW



FORDOMATIC



POWER BRAKES

Wagons by FORD, America's Station Wagon Specialist



RANCH WAGON POPULAR OPTIONS

Ranch Wagon buyers can continue saving throughout ownership with Ford's standard of engine thrift, the Mileage Maker Six. Those favoring extra "pep and pull" can select from Thunderbird 292 V-8, 352 or 390 Special V-8's. They'll find, too, that convenient Fordomatic and Power Tailgate Window pay for themselves many times over. (MagicAire Heater* is now included in the price of every Galaxie sedan and wagon.) Ranch Wagon buyers will probably want to consider additional options—Power Brakes, Cargo Cover and White Sidewall Tires. See pages 26-29 for full list of options.

*Delete option. See footnote, pg. 4

RANCH WAGON STANDARD EQUIPMENT

* Choice of Three Distinctive Interiors: Two Vinyl-and-Woven Plastic, One All-Vinyl * Choice of 12 Diamond Lustre Exteriors * Roll-Down Tailgate Window * Color-Keyed Ribbed-Vinyl on Loadspace Floor * Color-Keyed Textured Vinyl-Coated Rubber Floor Covering * Cigarette Lighter * Front Arm Rests and Ash Tray * Wide-Vision, Double-Swivel Safety Rearview Mirror * Dual Sun Visors (with retention clips) * Foam-Cushioned Front and Rear Seats * Front Seat Side Shields * Color-Keyed Lifeguard Steering Wheel with Chrome Horn Ring * Dome Light Controlled by Main Light Switch * Step-On Parking Brake with Instrument Panel Control Knob Release * Front Seat Belt Anchors * Mileage Maker Six Engine * Three-Speed Manual Transmission * Self-Adjusting Brakes * Single-Speed Electric Windshield Wipers * Full-Flow Oil Filter * Fully Aluminized Muffler * 30,000-Mile Fuel Filter

Loadspace for cargo or people, or people with lots of cargo. Galaxie wagons always take the **biggest** loads. Behind the front seat there's 93½ cu. ft. of space—over 5 feet wide and over 10 feet long to end of open tailgate (over 8 feet with tailgate closed!) . . . tops in convenient, **all-in-one-place** space. Tailgate opening is over 4 feet wide . . . loading height just a shade over 2 feet. To add extra ease to these extra-generous proportions, hidden torsion springs take all the work out of handling the tailgate. It practically flips open and shut by itself!

RANCH WAGON



Ford's Ranch Wagon in Ming Green



Five New Galaxie Wagons for '62

There are station wagons . . . and then there are Galaxie station wagons. And there is quite a difference. As a case in point, take any one of the five full-sized Galaxie wagons for '62. Built big and rugged to "shoulder the load" in the backwoods for fun or in the big city on business. Four, big, wide-opening doors . . . roll-down tailgate window . . . spacious, convenient, all-in-one-place cargo area (opposite) . . . handsome upholsteries (16 choices) that are all bears for wear and a cinch to clean. * Of course every Galaxie wagon has Ford's twice-a-year maintenance . . . 6,000 miles between service stops . . . and every other Ford service-saving feature. All this plus low Ford prices that begin with the Ranch Wagon (above)—big bargain of all big wagons!

CRUISE-O-MATIC



POWER STEERING



POWER BRAKES

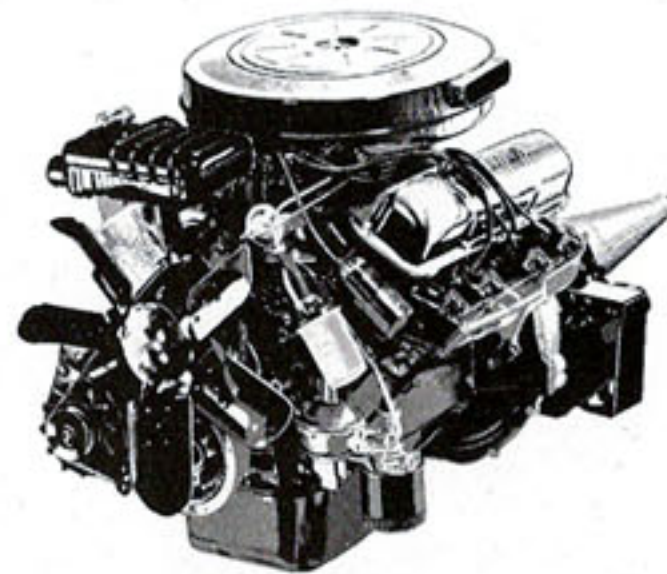

THUNDERBIRD 352 SPECIAL V-8

*Luxury was never
so Wonderfully Practical*



COUNTRY SEDAN POPULAR OPTIONS

Country Sedan owners who show a preference for V-8 "punch" can have the lively Thunderbird 292 V-8, the Thunderbird 352 Special V-8 or the high-stepping Thunderbird 390 Special. Cruise-O-Matic, with its dual-drive-range versatility, is a fine choice in "automatics." Power Steering and Power Brakes will find favor with many owners, while Console Range Radio is almost a "must." For added safety and comfort, Ford's Safety Package (Lifeguard padded dash and visors), Seat Belts and Tinted Glass are well worth considering. You'll find plenty of other popular wagon accessories listed on pages 26-29.

COUNTRY SEDAN STANDARD EQUIPMENT

Additional luxury items over and above Ranch Wagon equipment listed on page 20:

- * Choice of Six Distinctive Interiors: Five Vinyl-and-Woven Plastic, One All-Vinyl
- * Power Tailgate Window on 9-Pass. Model (optional on 6-passenger)
- * Removable Third Seat on 9-Pass. Model
- * Rich Chrome-like Mylar Highlights in Seat Fabric, Door and Side Trim Panels
- * Bright-Metal Roof Bows
- * Arm Rests, Front and Rear
- * Bright-Metal Inserts in Instrument Panel Control Knobs
- * Dome Light Controlled by Front Door Courtesy Switches and Main Light Switch
- * Bright-Metal Drip Rail along Roofline
- * Bright-Metal Side Window Frames
- * Attractive Bright-Metal Body Side Molding with Complementary-Colored Insert
- * Bright-Metal Fender Ornaments
- * Distinctive Grille-Styled Bright-Metal Panel at Rear

6-PASSENGER SEAT FOLD-DOWN

New Galaxie 6-passenger wagons feature the newest, quickest and easiest-folding second seat in the wagon world! To convert it, simply (1) release dual safety latch (which operates from either side of the car to save you steps). (2) Push the seat forward and over on top of the cushion. (A torsion bar assist makes this child's play . . . helps you again when you raise the seat.) Back plate slips neatly into place by itself, and you have flat, level loadspace from front seat to tailgate!



COUNTRY SEDANS

Country Sedans are the "more-the-merrier" Galaxie wagons—one carries six, the other nine—and the most popular big wagons built by Ford. ☉ The 6-passenger model has features enough to top any wagon lover's preferred list: spacious, convenient, *all-in-one-place* loadspace . . . new, quick-converting second seat (opposite) . . . foam-cushioned front and rear seats and a long list more! ☉ The 9-Passenger Country Sedan's power tailgate window (std.) is but one convenience in common with America's prestige wagon, the Country Squire (next page): ☉ An elegant pair—but wonderfully practical and economical too. Because both are loaded with the savings of Ford's exclusive twice-a-year (or 6,000-mile) maintenance!

*6-Passenger Country Sedan
in Corinthian White
(Offered also in
9-passenger model)*

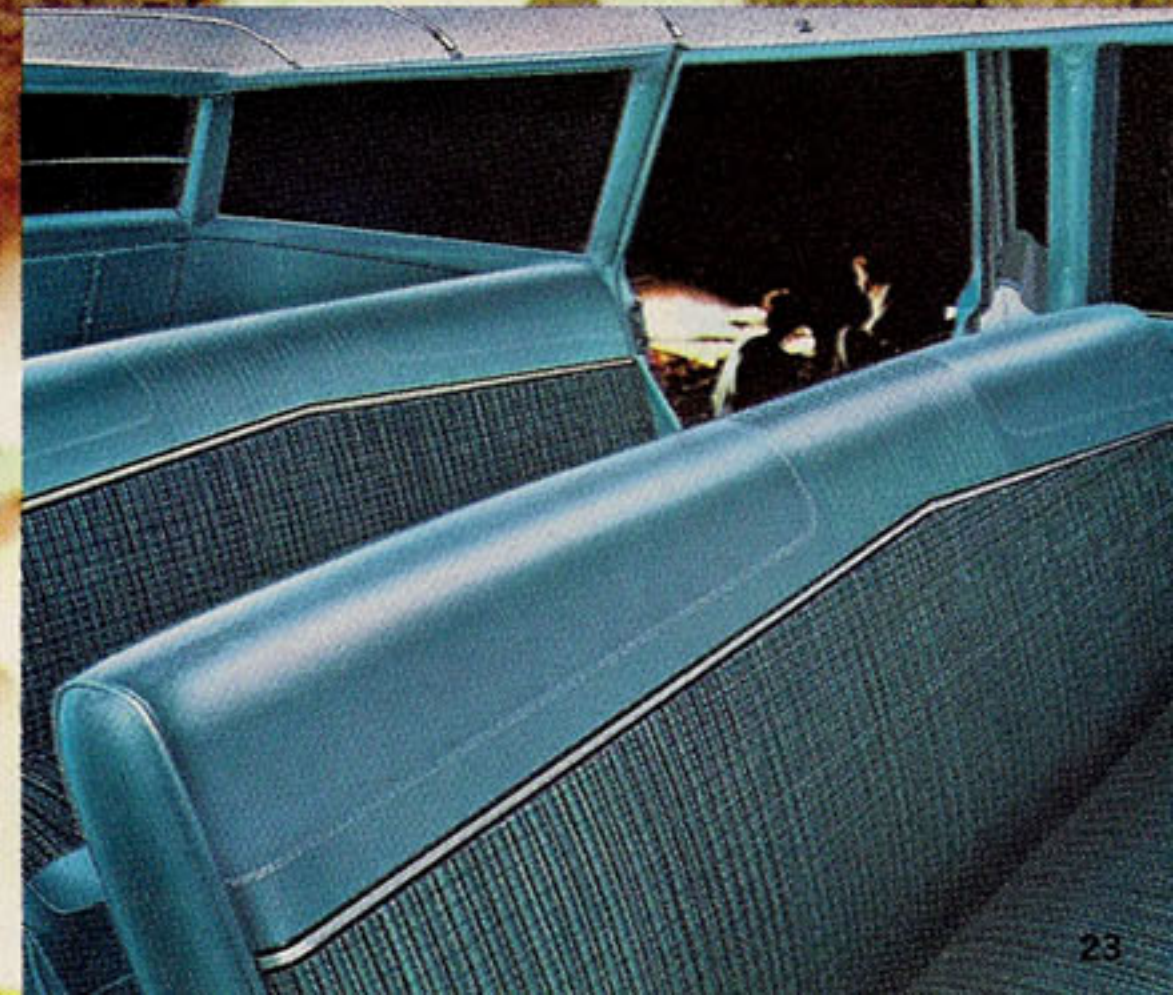

POWER WINDOWS



POWER SEAT

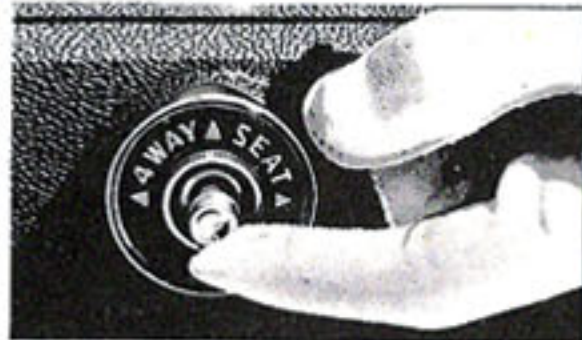

SELECTAIRE

COUNTRY SQUIRE POPULAR OPTIONS

Country Squire buyers can select from a wide range of options in keeping with Squire elegance. For power, they can choose the Thunderbird 390 Special V-8 (identified with distinctive "390" fender emblem) and Cruise-O-Matic Drive. If they want to go "fully automatic," they can select Power Front Seat, Power Windows, Power Steering and Power Brakes. SelectAire, Ford's all-in-one, air-conditioning-heating system, is another top suggestion for year-round driving comfort.



THUNDERBIRD 390 SPECIAL V-8

Glamorous as any Galaxie...even when it's Hard at Work

9-PASSENGER SEAT FOLD-DOWN

To convert Galaxie 9-passenger wagons, (1) rotate second seat cushion forward and lower support legs to rest squarely on floor. (2) Release safety latches behind seat back and flip down. (Second seat is divided so one-third may be lowered to provide a "walk-through" to the rear and still leave two-thirds up for passengers.) With second seat down, (3) simply slip out third seat foam cushions and flip down seat back. Loadspace provided totals 93½ cu. ft.—over 10 feet to end of open tailgate (over 8 feet with tailgate closed)!



COUNTRY SQUIRE STANDARD EQUIPMENT

Additional luxury items over and above Country Sedan and Ranch Wagon equipment listed on pages 20 and 22:

- * Distinguished Wagon Styling, with Lined Oak Glass Fiber Moldings Enclosing Walnut-Grained Steel Panels on Body Sides and Rear
- * Power Tailgate Window Standard on Both 6- and 9-Passenger Models
- * Choice of Seven Distinctive Interiors: Three All-Vinyl, Four Vinyl-and-Cloth
- * Choice of 11 Diamond Lustre Exteriors
- * Richly Pleated Seat Fabrics, Door and Side Trim Panels, Highlighted with Sparkling Chrome-like Mylar
- * Color-Keyed Wall-to-Wall Carpeting (textured vinyl on 9-pass. third seat floor)
- * Self-Regulating Electric Clock
- * Chrome-Backed Rearview Mirror
- * Backup Lights (centered in taillights)

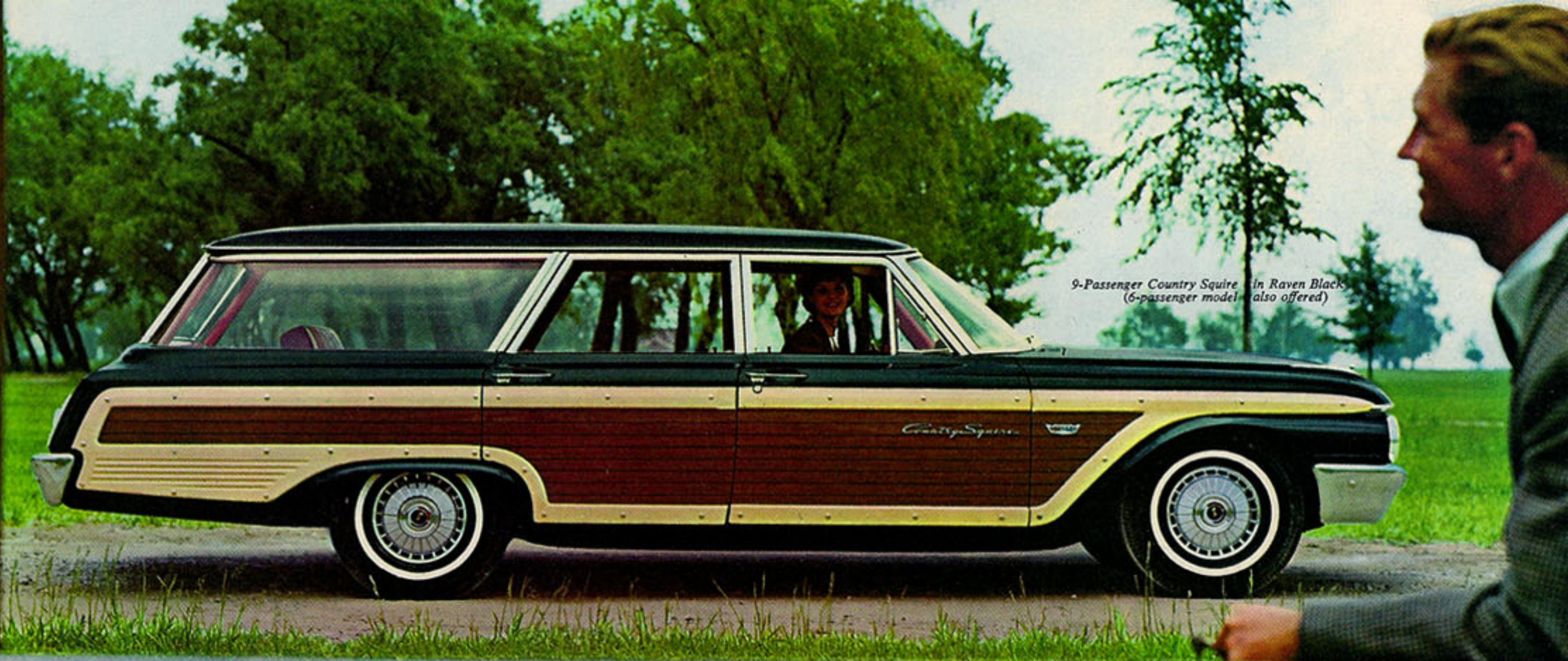

9-Passenger Country Squire in Raven Black (6-passenger model also offered)

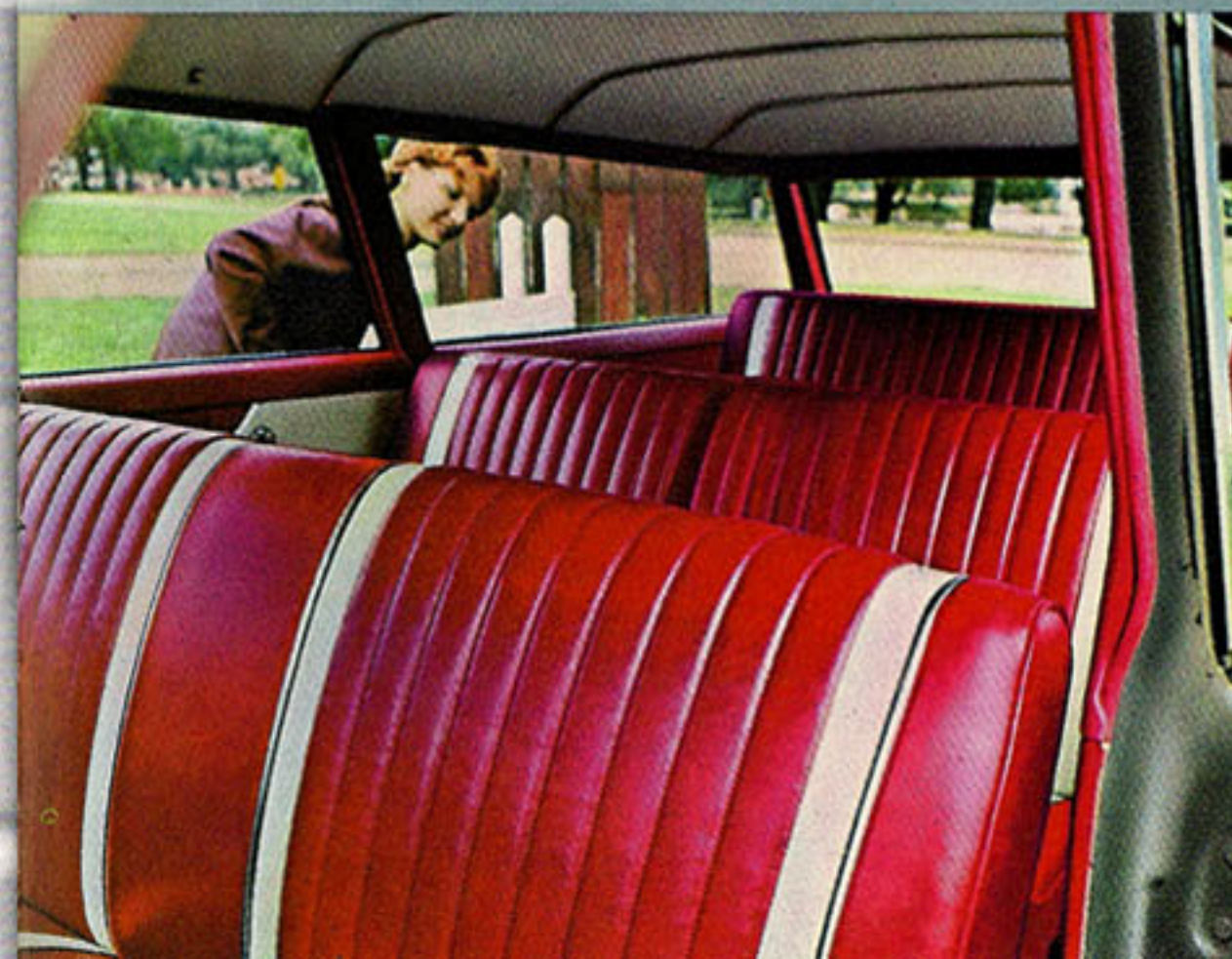

COUNTRY SQUIRES Here is exclusive elegance and distinction from the finest the wagon world has to offer. Its interior speaks of Galaxie luxury. Its quiet way with the road whispers of Ford quality, new standard of the industry. Its spirited, responsive V-8 action and ease of handling murmur Thunderbird.

⊗ Choose either the 6- or 9-Passenger Country Squire; each includes many standard features tagged "extra cost" on lesser wagons. (Power tailgate window, for example.) But don't be misled by the glamour. Country Squires convert to their 93½ cu. ft. of cargo space just as fast . . . to work just as hard as the other Galaxie wagons!

Ford ACCESSORIES Selector

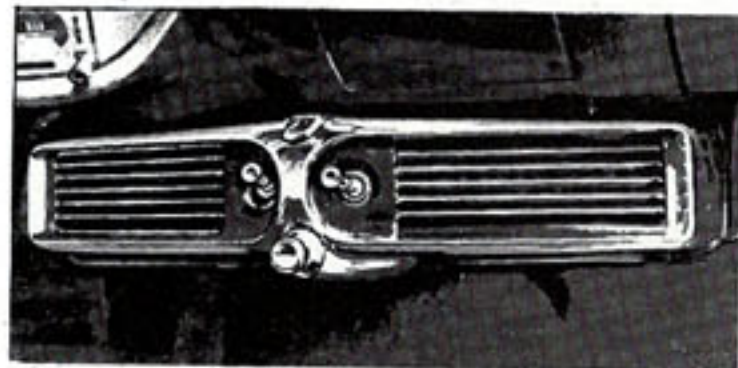

SELECTAIRE CONDITIONER. Ford's all-in-one, air-conditioning-heating system. Provides the finest air conditioning available to cool, filter and dehumidify incoming fresh air. Capacity sufficient to pleasantly cool a five-room house. Three-speed blower. Adjustable selector provides precise control. Taking over for efficient cold-weather heating and defrosting, after simple adjustment, is the built-in heater. (With all except Six and 406 V-8's.)



POLARAIRE CONDITIONER. An outstanding car air conditioning system devoted entirely to your summertime cooling comfort. Moderately priced, too. Four-room house capacity. Cools, cleans, dehumidifies and depollenizes air. Five adjustable outlets, push-button controls, powerful dual blower. (Available with all except 500/XL models and 406 V-8's.)

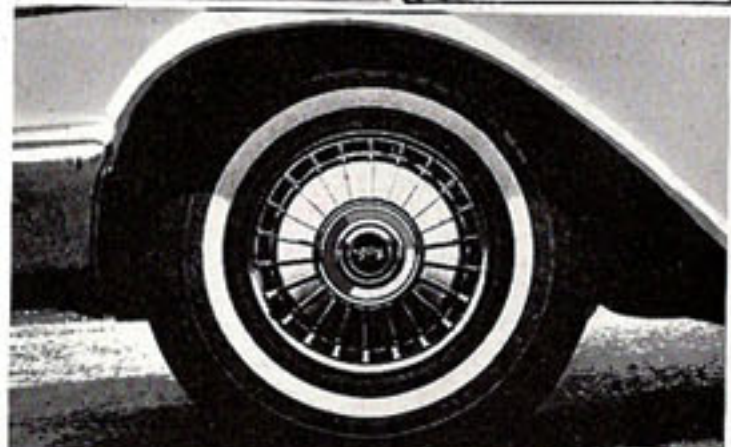

WHEEL COVERS. Available in two handsome designs. Deluxe cover (shown) is standard on 500/XL models, optional on Galaxies and 500's. A second wheel cover design for 15-inch wheels is part of the special equipment package with 406 V-8's on Galaxie 500/XL's, and optional equipment when 406 V-8's are ordered on Galaxies and 500's.

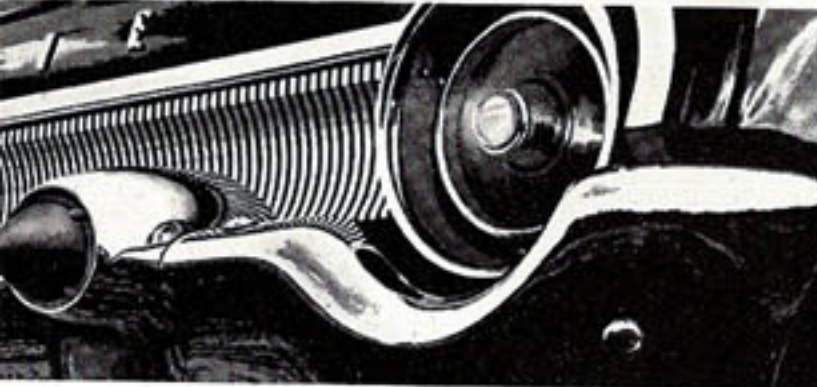

SPOTLIGHT/MIRROR. Handsome visored spotlight with mirror styled in at rear. Controlled from inside car, spotlight throws half-mile beam in clear weather, has many helpful nighttime uses. Mirror is handy 24-hour driving aid, can also be adjusted from the driver's seat. Two types available.

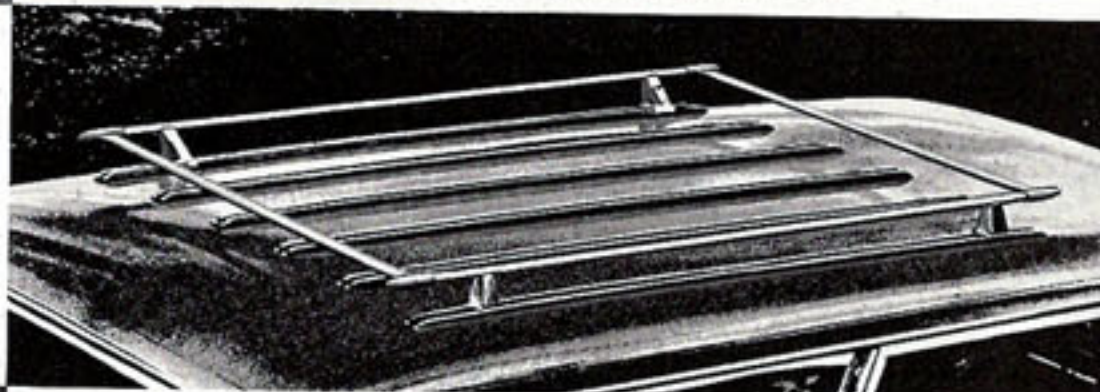

WAGON LUGGAGE RACK. A handsome addition to any Ford wagon, this handy roof-top luggage rack has a big, wide 65 x 43-inch storage area that gives you extra loadspace, lets you save the rear seat for passengers. Sturdily constructed of gleaming, rust-resistant metal to stay bright with little care.



BACKUP LIGHTS AND BUMPER GUARDS. Many owners pair these two options. Backup lights, centered in Galaxie's big, circular taillights, illuminate drive path for safer, easier night driving. (Std. on Galaxie/500's, Galaxie 500/XL's and Country Squires.) Styled-in front and rear bumper guards with rubber inserts protect bumpers from marring or scratching. (Rear guards not available on wagons.)

PLUS . . . Whitewall Tires (narrow band type) ◊ Two-Tone Paint ◊ Electric Windshield Washer ◊ 2-Speed Electric Wipers ◊ Tinted Glass ◊ Rear Radio Speaker ◊ Deck Lid Antenna ◊ Exterior Rearview Mirror (3 designs) ◊ Interior Non-Glare Mirror ◊ All-Vinyl Interior Trim (Galaxie/500 sedans and hardtops) ◊ Rear Fender Shields ◊ Hood Ornament ◊ Door Edge Moldings ◊ Seat Covers ◊ Ventilated Seat Cushions ◊ Cushion-Top Cover ◊ Contour Floor Mats (front, rear, twin front) ◊ Tissue Dispenser ◊ Litter Disposal (vacuum-operated or plastic) ◊ Driver's Seat Deck Lid Release (except wagons) ◊ Locking Gas Cap ◊ Tachometer ◊ Power Exhaust Pipes (406 V-8's only) ◊ Heavy-Duty 70 Amp-Hr Battery ◊ Heavy-Duty Rear Axle and/or Heavy-Duty Suspension (wagons) ◊ Load-Leveler Shock Absorbers ◊ Deletion of MagicAire Heater ◊ Luggage Rack Cargo Cover (wagons) ◊ Cargo Floor Mat (wagons) ◊ and many others



1. PARKING BRAKE SIGNAL. This brake-saving Ford option reminds you when parking brake is on. Red light on instrument panel flashes on when you start the car—stays on till you release the brake.

POWER ASSISTS. **2. Ford's Master-Guide Power Steering*** does up to 85% of the steering work for you, yet lets you retain the "feel of the road." **3. Power-Lift Windows** are operated by individual controls at all windows plus master control at driver's position. Fifth button lets driver lock out all windows but his own. **4. Power Front Seat†** with unlimited settings and synchronized tilting back lets you pick the position you like best with automatic finger-tip control (driver's seat only on Galaxie 500/XL models). **5. Swift Sure Power Brakes*** reduce braking effort as much as 55%. Low pedal means less foot travel, precision control.

6. CONSOLE RANGE RADIO. A transistorized car radio that gives you powerful reception and unusual high-fidelity tone, along with automatic push-button tuning. Five push buttons can be easily pre-set to the stations of your choice. Printed circuits for greater reliability.

7. ELECTRIC CLOCK. Ford's electric clock is self-regulating and style-blended with dials and controls of the '62 Galaxie instrument panel. Clock face has full-sweep second hand; hands and numerals are illuminated at night. (Std. on Galaxie/500 and Galaxie 500/XL's and Country Squires.)

LIFEGUARD DESIGN. Every '62 Galaxie gives you these Lifeguard Design features as standard equipment: **Safety-Padded Arm Rests; Deep-Dish 3-Spoke Steering Wheel; Double-Swivel, Shatter-Resistant Rearview Mirror and Double-Grip Door Locks.** Ford Lifeguard Design options available at slight extra cost include: **8. Padded Instrument Panel and 9. Cushioned Sun Visors** of shock-absorbing foam material covered in handsome leather-grained vinyl; **10. Safety Seat Belts,** floor-anchored to help hold you firmly in your seat upon sudden stop or impact; **Lifeguard Jr. Rear Door Locks** to prevent tiny hands from unknowingly opening rear doors.

*Not available in models equipped with 406 V-8's
†Not available in models (except Galaxie 500/XL's) equipped with 4-speed manual transmission

FORD COLOR & upholstery selector

COLOR AND UPHOLSTERY GUIDE. The color guide below illustrates the 13 Diamond Lustre Enamels available for 1962. By simply matching color code letters and upholstery swatches you can determine the interior trim choices available with your favorite new Ford model and color. For example, a Galaxie sedan with blue vinyl and cloth upholstery comes in Corinthian White (M), Baffin Blue (F), Viking Blue (E) or Oxford Blue (H).

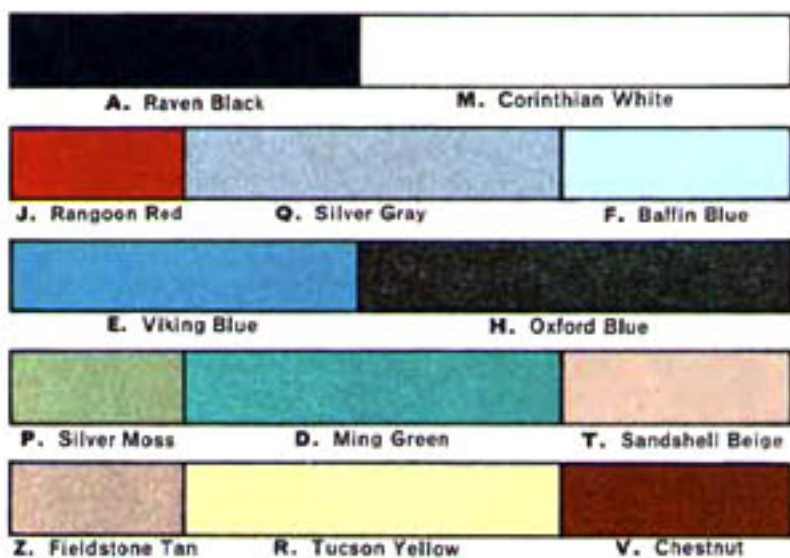

TWO TONE COLOR GUIDE. There are up to 24 Diamond Lustre Two Tone combinations available for '62 as shown below. (Sunliners and Country Squires take Single Colors only.) The first letter represents upper body color, the second, lower body color. For example, "M/A" is Corinthian White upper, Raven Black lower. In most cases, the lower body determines interior trim choices. For exceptions, consult your Ford Dealer.

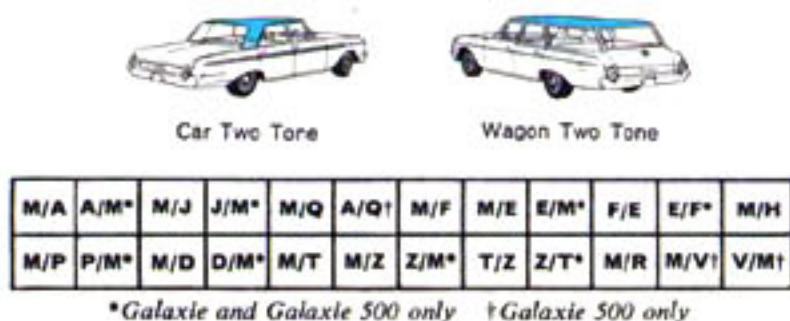

EXTERIOR COLORS	All Models A • M • J • Q	Galaxie & Galaxie 500's A • M • J • Q • R Sunliner A • M • J • Q • P • R All Others A • M • J • Q	Galaxie 500's & Sunliner M • V Ranch Wagon A • M • J • Q • F • E • H • P • D • T • Z • R Country Squire M • T • Z • R	Country Sedan M • F • E • H • P • D • T • Z • R All Others M • T • Z • R	All Models M • D	Country Sedan M • P • T • Z • R All Others M • P	Ranch Wagon & Country Sedan A • M • Q • F • E • H All Others M • F • E • H
GALAXIE	vinyl/cloth	vinyl/cloth	vinyl/cloth	vinyl/cloth	vinyl/cloth	vinyl/cloth	vinyl/cloth
GALAXIE 500 SEDANS & VICTORIAS	pleated vinyl/cloth	pleated vinyl/cloth	pleated vinyl/cloth	pleated vinyl/cloth	pleated vinyl/cloth	pleated vinyl/cloth	pleated vinyl/cloth
	pleated all-vinyl	pleated all-vinyl	pleated all-vinyl	pleated all-vinyl	pleated all-vinyl	pleated all-vinyl	pleated all-vinyl
SUNLINER	pleated all-vinyl	pleated all-vinyl	pleated all-vinyl	pleated all-vinyl	pleated all-vinyl	pleated all-vinyl	pleated all-vinyl
RANCH WAGON			all-vinyl (steerhead)			vinyl/woven plastic	vinyl/woven plastic
COUNTRY SEDAN	all-vinyl	vinyl/woven plastic		vinyl/woven plastic	vinyl/woven plastic	vinyl/woven plastic	vinyl/woven plastic
COUNTRY SQUIRE	pleated all-vinyl	pleated vinyl/cloth	pleated all-vinyl	pleated vinyl/cloth	pleated vinyl/cloth	pleated vinyl/cloth	pleated vinyl cloth or all-vinyl

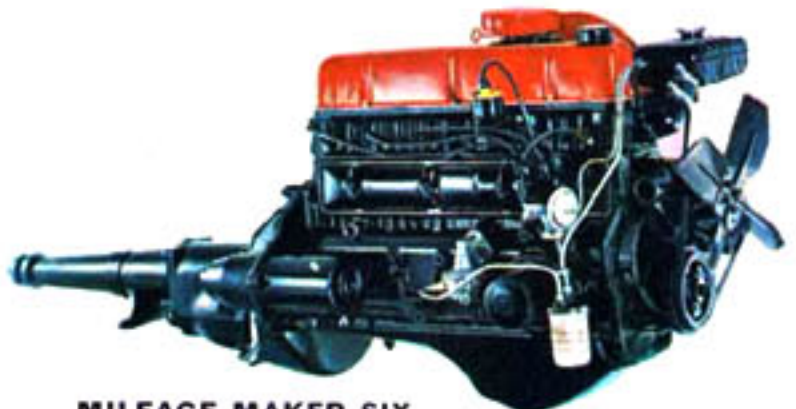

FORD POWER TEAM SELECTOR

MILEAGE MAKER SIX
Ford's standard engine and your selection for top gas economy and all-round thrift as proved by *billions* of owner-driven miles! New self-adjusting valves . . . short-stroke design for top efficiency with minimum maintenance. *Horsepower:* 138 at 4,200 rpm.



THUNDERBIRD 292 V-8
If you want V-8 dash on *regular* gas, this engine, Ford's most popular V-8, is your choice. Two-barrel carburetor, automatic choke, precision fuel-metering system blend performance with economy all through speed range. *Horsepower:* 170 at 4,200 rpm.

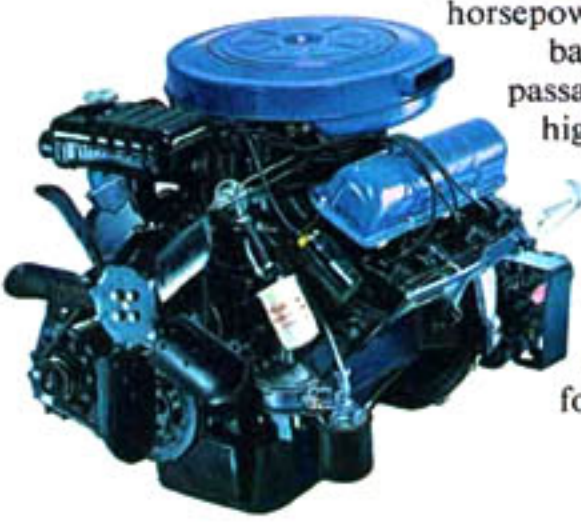

THUNDERBIRD 352 SPECIAL V-8
Turns *regular* gas into spirited GO—220 horsepower at 4,300 rpm! Two-barrel carburetion, direct passage intake manifolding, high-lift camshaft are top features. Electronically mass-balanced (a Ford "first" and quality manufacturing step in production of all Thunderbird V-8's) for smooth, quiet power and long life.



THUNDERBIRD 390 SPECIAL V-8

This is the Thunderbird's own magnificent powerplant . . . a V-8 performance masterpiece! Four-barrel carburetor, Precision Fuel Induction, aluminum valves with hydraulic lifters . . . a few of many great engine features. *Horsepower:* 300 at 4,600 rpm. (Also available on all models except wagons, "390" High-Performance and Super High-Performance engines with up to 401 horsepower. Your Ford Dealer can supply details on these special V-8 options.)



Manual Transmissions. Conventional 3-speed with steering column shift lever, standard equipment on all models. Optional 4-speed transmission, with floor-mounted "short stick" shift, available with Thunderbird 352 Special and all 390 V-8 engines only.



Ford Overdrive. Available with all engines to stretch more miles from each gallon. Automatic fourth gear permits engine to loaf at 28% less rpm's. And flooring accelerator provides instant downshift for passing.



Fordomatic. Two-speed smoothness combined with famed reliability. Kick-down for passing up to 55 mph. Available with Mileage Maker Six, Thunderbird 292 and Thunderbird 352 Special V-8's.



Cruise-O-Matic. Ford's dual-range automatic with normal drive starting in low plus second range starting in intermediate for gentler starts on ice or snow. A sparkling performance mate to the Thunderbird 292 V-8, 352 and 390 Special V-8's. (Not available with Mileage Maker Six.)



Quality by Ford...

BODY INSULATION. To achieve Ford's lush, quiet "silent as a secret" ride, inside metal surfaces of *doors, hood and deck lid, fenders and quarter panels* are sprayed with heavy sound-absorbent mastic. *Dash panel, cowl top and sides, roof panel* are swathed in thick fiberglass blankets or equivalent materials. Layers of "waffle" felt, amberlite and jute provide a "sound barrier" for the *floor pan*. Body sealers are new . . . weather stripping improved. As just one of many checks on body quality, *every* new Ford is completely water-spray tested.

WIDE-CONTOURED FRAME. Ford's *Wide-Contoured* frame provides a wide, firm base for the ride as it surrounds passengers with protection of double-channel side rails. Frame has new cross members especially designed to absorb harshness and vibration *before* these annoyances can be transferred to body and passengers.

BODY STRUCTURE. A solid foundation for Ford quality. *Heavy-ribbed floor* with five sturdy cross members for underbody strength and rigidity. "Double-hat" *roof supports* provide greater crossover strength and rigidity for top sheet metal. *Double-paneled hood and deck lid.* Quality design and construction eliminates possible source of vibration, noise. *Galvanized rocker panels.* Long-term protection for these vital underbody parts against rust and corrosion. *Diamond Lustre Enamel.* Protective beauty for the body and all sheet metal. Just wash and remove any corrosive substances with a good grade of polish. It *never* needs waxing.

CHASSIS. New *lubricants* allow '62 Fords to go 30,000 miles between lubrications of major chassis components, such as suspension, steering linkage, front wheel bearings and universal joints. *Ball-Joint front suspension* lets wheels "walk" up and over bumps, helps reduce brake "dive." *Asymmetrical Rear Suspension* with 60-inch rear springs mounted on the axle forward of spring centers. This design feature gives every Ford a solid, level ride . . . further helps to reduce front end "dive" on braking, rear end "squat" on take-off.



MORE COMFORT AND CONVENIENCE

Next time at your Ford Dealer's, be sure to spend a few minutes in one of his display cars. Galaxie sedan or wagon, note first how Ford's extra-wide-opening doors let you *step in* easily and gracefully. Seats are comfortably high, wide and deep . . . soft as your sofa . . . yet with firm support for your back and shoulders. Notice, too, how much room there is for heads, shoulders, hips and legs . . . even with *six persons* in the car. This is the "built-for-people" comfort for which Ford is famous. Convenience is a Ford strong point, too. Galaxie's "vacation-volume" trunk is a prime example. There's 28 cu. ft. of space, with the widest opening—over 5 feet—in Galaxie's field! It's flat, level space and lined, of course, to protect your luggage.

Here are some of the many quality features that make Galaxie the fine car of its field

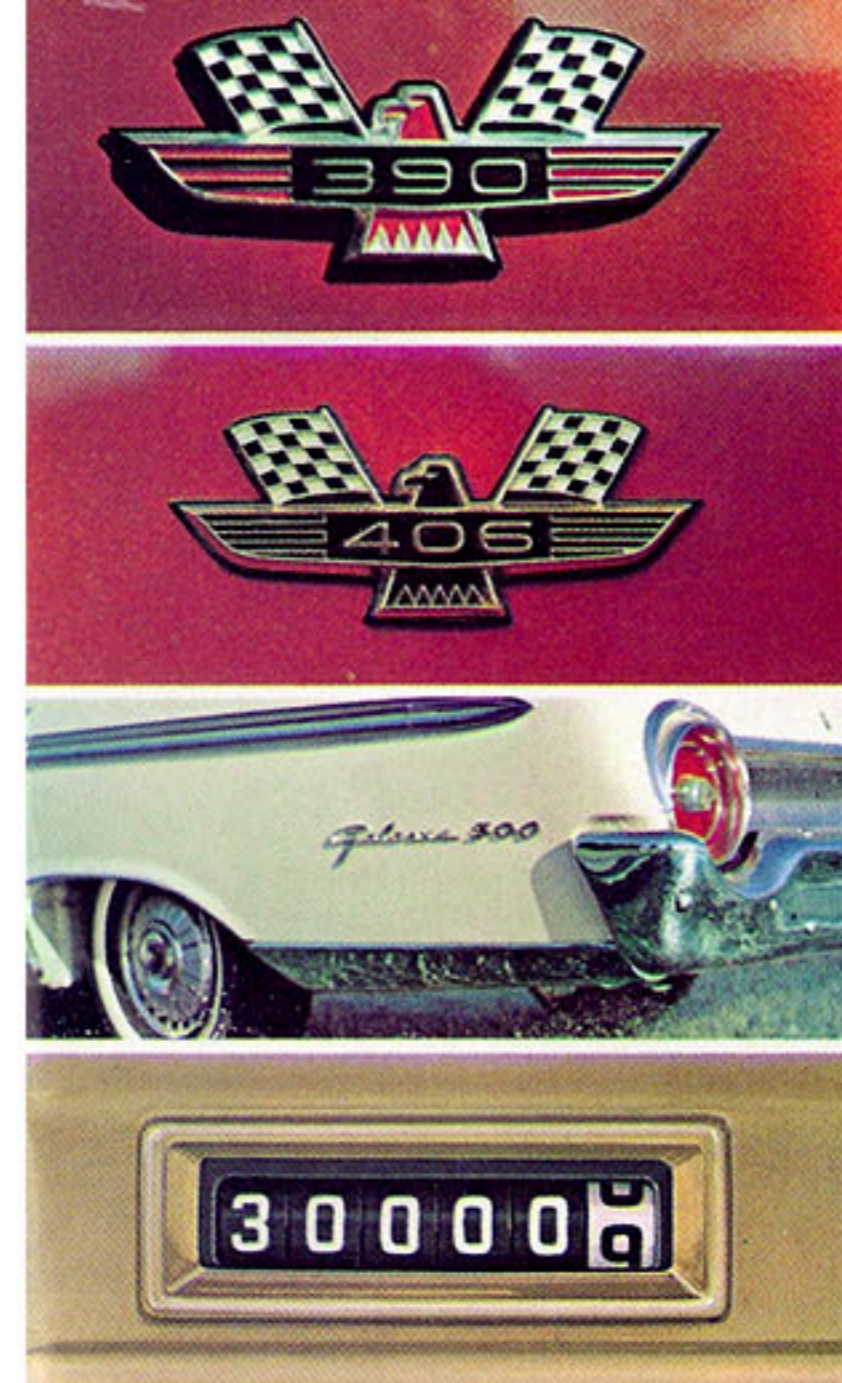

FINER PERFORMANCE

A Thunderbird V-8 can make a spirited difference in your driving. Whether it's the famous 390 Special, a 406 High-Performance V-8, or one of the regular gas Thunderbird V-8's, Ford has designed these engines to be wonderfully flexible. Every Thunderbird V-8 promises sparkling performance—and how it *delivers!* At the light, response is eager . . . take-off smooth as silk. On the thruway, you just sit back and watch the miles melt away. You sweep up hills without half trying. But probably you'll value the supple power of a Thunderbird V-8 most in passing. Your toe signals the throttle . . . you move swiftly without lag or labor. You're out, around and back in your own lane . . . mighty happy that it's a *Thunderbird V-8* under the hood!

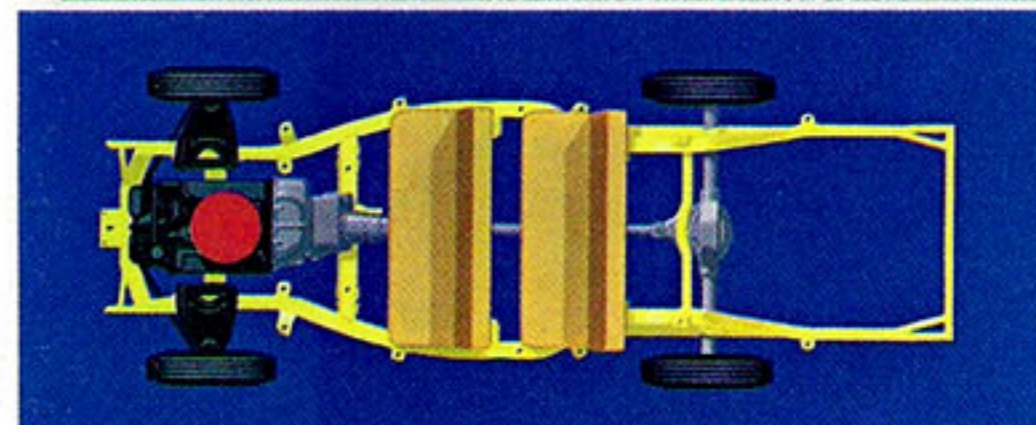

MORE ECONOMY AND DURABILITY

By now almost everyone knows that Ford was first with the most important service-saving, money-saving features on any new car in years. Self-adjusting brakes . . . longer-lived muffler . . . galvanized rocker panels. Now Ford steps out ahead again with twice-a-year maintenance . . . 6,000 miles between routine service stops. You breeze along in your Galaxie sedan or wagon for 30,000 miles between major lubrications . . . 6,000 miles between oil changes* and minor lubes. You even go two years or 30,000 miles between changes of engine coolant-antifreeze (with built-in anti-rust radiator protection, too!) You'll save money as you drive. But that's not all. Each of these Ford benefit features gives the Galaxie you buy now a *longer* "prime of life" . . . the likelihood of *greater* dollar value return at trade-in!

*After first 1,000-mile change

FINER RIDE, HANDLING AND SAFETY

In addition to its finer performance (above), you owe yourself a test drive in a new Galaxie to sample its marvelous ride and handling. Ball-Joint front suspension teams up with offset-mounted 60-in. rear leaf springs to soak up bumps . . . minimize start-up "squat," quick-stop "dive." Galaxie's Wide-Tread design (61 inches front, 60 inches rear) combined with long wheelbase (119 inches) provide stability and control through curves and corners. Galaxie steering (with easy-working 30 to 1 ratio) is the next best thing to power steering. Famous Ford safety features ride with you, of course. Brakes are "tailored to weight" and safety. Thus wagons, heavier than sedans, have bigger brakes. And Galaxie's Wide-Contoured frame better *protects all passengers* with double-channel girders of steel.

SPECIFICATIONS

ENGINES: 138-hp Mileage Maker Six (standard)—223-cu. in. displ.; 3.62" bore x 3.60" stroke; 8.4 to 1 comp. ratio; regular fuel; single-venturi carburetor; manual choke; aluminized valves with mechanical automatic adjusters; precision-molded crankshaft with four main bearings; oil capacity, with filter change, 5 qt.; single exhaust.

170-hp Thunderbird 292 V-8 (standard 500/XL's, optional on all other models)—292-cu. in. displ.; 3.75" bore x 3.30" stroke; 8.8 to 1 comp. ratio; regular fuel; 2-venturi carburetor; automatic choke; precision-molded crankshaft, copper-lead main (five) and con. rod bearings; oil capacity, with filter change, 6 qt.; Y-type single exhaust (dual on Sunliner).

220-hp Thunderbird 352 Special V-8 (optional)—352-cu. in. displ.; 4.00" bore x 3.50" stroke; 8.9 to 1 comp. ratio; regular fuel; 2-venturi carburetor; automatic choke; aluminized valves with hydraulic lifters for automatic valve adjustment; precision-molded crankshaft, copper-lead main (five) and con. rod bearings; oil capacity, with filter change, 6 qt.; Y-type single exhaust (dual on Sunliner).

300-hp Thunderbird 390 Special V-8 (optional)—390-cu. in. displ.; 4.05" bore x 3.78" stroke; 9.6 to 1 comp. ratio; premium fuel; 4-venturi carburetor; automatic choke; aluminized valves with hydraulic lifters for automatic valve adjustment; precision-molded crankshaft, copper-lead main (five) and con. rod bearings; oil capacity, with filter change, 6 qt.; dual exhausts. **385-hp Thunderbird 406 High-Performance V-8** with 11.4 to 1 comp. ratio and 4-barrel carburetion, and **405-hp Thunderbird 406 Super High-Performance V-8** with 11.4 to 1 comp. ratio and 6-barrel carburetion also available for all models except wagons. Included as part of the available equipment package required with either High-Performance V-8: heavy-duty fade-resistant brakes, 15-in. wheels (including full wheel covers on 500/XL models), 6.70 x 15 or 7.10 x 15 4-ply nylon black sidewall tubeless tires, heavy-duty springs and shock absorbers. For further details, consult your Ford Dealer.

ENGINE FEATURES: For greater economy and longer life, Ford engines have Short Stroke, low-friction design; Deep-Block construction; Free-Turning overhead intake and exhaust valves (except 406 V-8's); Super Filter air cleaner with reusable element; high-capacity in-line 30,000-mile fuel filter; Full-Flow disposable-type oil filter; Cross-Flow cooling system with separate top reserve tank and 180° Positive-Action thermostat; 2-yr. or 30,000-mile engine coolant-antifreeze (available—installed in production); 12-volt electrical system; weatherproof ignition with Static-Ban constant resistance wiring and air-cooled distributor points; triple-seal 18-mm. Turbo-Action spark plugs; 66-plate, 55 amp-hr battery (78-plate, 65 amp-hr with Special V-8's and automatic transmissions); single muffler all-aluminized (dual mufflers of aluminized and stainless steel) with aluminized integral tailpipe(s) mounted at rear of frame. All engines electronically mass-balanced for extra smoothness.

CLUTCH and MANUAL TRANSMISSIONS: Semi-centrifugal clutch with full-weighted levers for more positive engagement; suspended pedal. Face diameter—9½" with Six, 10½" with 292 V-8, 11" with all other V-8's. **3-Speed** manual has new clutch interlock in low and reverse; ratios (to 1): Six—1st 3.20, 2nd 1.85, direct 1.00, rev. 3.38; 292 V-8—1st 2.78, 2nd 1.61, direct 1.00, rev. 3.38; 352 and 390 Special V-8's—1st 2.37, 2nd 1.51, direct 1.00, rev. 2.81. **4-Speed** manual option with console-mounted stick shift on 500/XL models, floor-mounted stick shift on all other models; required on 406 V-8's, available on 352 and 390 V-8's; ratios (to 1): 1st 2.36, 2nd 1.78, 3rd 1.41, direct 1.00, rev. 2.42. **Overdrive** (optional) is same as above 3-speed plus an automatic 4th gear which cuts in above 28 mph, cuts out below 21 mph (approx.). Downshift to direct by flooring accelerator. Lockout control on instrument panel. Tailored-to-engine ratios (to 1): Six and 292 V-8—1st 2.80, 2nd 1.69, direct 1.00, OD .70, rev. 3.80; 352 and 390 Special V-8's—1st 2.49, 2nd 1.59, direct 1.00, OD .72, rev. 3.15.

AUTOMATIC TRANSMISSIONS: Torque converter in combination with compound planetary gear set. Effective engine braking in "L" position. Liquid cooled. Selector lever on steering column (except with Galaxie 500/XL models, which have "sport-stick" mounting in the console). **Fordomatic Drive** (optional with all engines except 390 and 406 V-8's) features simplified design, lightweight cast-aluminum construction, minimum servicing. Two forward gear ratios, one reverse (to 1): low 1.75, direct 1.00, rev. 1.50; converter stall ratio

2.6 with Six and 292 V-8, 2.5 with 352 Special V-8. In "D" range gives brisk, smooth starts in low. New vacuum control provides smoother shifting, minimum servicing. Selector sequence P-R-N-D-L. **Cruise-O-Matic Drive** (std. on 500/XL models with 292 V-8; optional in all other models and/or with all engines except Six and High-Performance V-8's) features lightweight construction with cast-aluminum converter housing. Two selective drive ranges: Three-speed range starting in low for all normal driving, or two-speed range starting in intermediate for more sure-footed driving on slippery surfaces. Three forward gear ratios, one reverse (to 1): low 2.40, intermediate 1.47, direct 1.00, rev. 2.00; converter stall ratio 2.1. Vacuum control provides smooth, precise and permanently coordinated-with-engine shifting, minimum servicing. Selector sequence: 500/XL's P-R-N-D₂-D₁-L; all others P-R-N-DRIVE-L.

REAR AXLE: Semi-floating type with deep-offset hypoid gears. Straddle-mounted drive pinion. **Torque-Tailored Axle Ratios** (to 1): **Conventional Drive—3-Speed Manual:** Wagons 3.89 with Six and 292 V-8, 3.56 with Special V-8's; Other models: 3.56 with all engines except 406 V-8's; **4-Speed Manual:** 3.56 with 352 and 390 Special V-8's, 3.50 with 406 High-Performance V-8's. **Overdrive—3.89** with Six or 292 V-8, 3.56 with 352 and 390 Special V-8's. **Fordomatic Drive—Wagons:** 3.56 with Six and 292 V-8, 3.00 with 352 Special V-8; Other models: 3.56 with Six, 3.00 with 292 V-8 and 352 Special V-8. **Cruise-O-Matic Drive—Wagons:** 3.56 with 292 V-8, 3.00 with Special V-8's; Other models: 3.00 with 292 V-8 and Special V-8's. **Optional:** Heavy-duty axle for wagons with higher capacity wheel bearings, larger diameter shafts.

WIDE-CONTOURED FRAME: Strong box-section design with flexible inner channel, new more flexible front cross members and other refinements to reduce road harshness and vibration for softer, more luxurious ride. Sunliner has 4 cross members plus X-member, others have 5 cross members. Side rails extend outside passenger area, for better foot room and increased side protection. Silent-Grip body mounts.

FRONT SUSPENSION: Swept-Back, Angle-Poised Ball-Joint type with wide-base coil springs for softer ride, easier steering. Ball joints packed with special 30,000-mile grease retained by full life seals. With V-8 models and Six in wagons, front end has rubber-bushed ride stabilizer to control roll on turns. Internally mounted shock absorbers.

REAR SUSPENSION: Asymmetrical, variable-rate design with rear axle located well forward from center of springs for anti-dive and anti-squat on braking and acceleration. Extra-long, gentle-rate, leaf-type springs with wide spring base provide a soft, stable, leveled ride. Outboard mounted. Tension-type shackles. Diagonally mounted shock absorbers.

STEERING: Precision-control, low-friction recirculating-ball type steering gear with anti-friction bearings throughout plus high ratio for easier steering. Flexible coupling in steering shaft insulates steering wheel. Symmetrical linkage with nylon bearings in tie-rod and pitman arm pivots are packed with special 30,000-mile grease retained by full life seals. Over-all steering ratio 30 to 1; with power steering, 25 to 1. Turning diameter approx. 41 ft.

BRAKES: Self-adjusting hydraulic brakes with double-sealed, self-energizing design. Brakes adjust automatically when applied while car is moving backwards. Easy-operating suspended pedal. Dash-mounted master cylinder. Grooved 11-inch composite drums for maximum cooling. Total lining area is 234 sq. in. on wagons, 212 sq. in. on other models. Foot-operated parking brake with pull-out release knob on instrument panel. Optional Swift Sure power brakes have special low pedal.

TIRES: 4-ply, black, tubeless with Tyrex Rayon cord and Soft-Tread design. Safety-type rims. Wagons—8.00 x 14 on 6" rims. Other models—7.50 x 14 on 5½" rims, except 8.00 x 14 tires on 5½" rims with combination of Special V-8's and air conditioning. Optional 6.70 x 15 or 7.10 x 15 nylon tires required with 406 V-8's. White narrow band sidewall tires optional. For wagons optional 8.00 x 14 6-ply tires recommended with heavy-duty suspension and axle options for greater cargo-carrying capacity.

PRICES: All Power Assists, Optional Equipment and Accessories as well as some items illustrated or referred to as options, optional or available in this catalog are at extra cost. For the price of the model with the equipment you desire, see your Ford Dealer.

SEDAN AND HARDTOP DIMENSIONS*

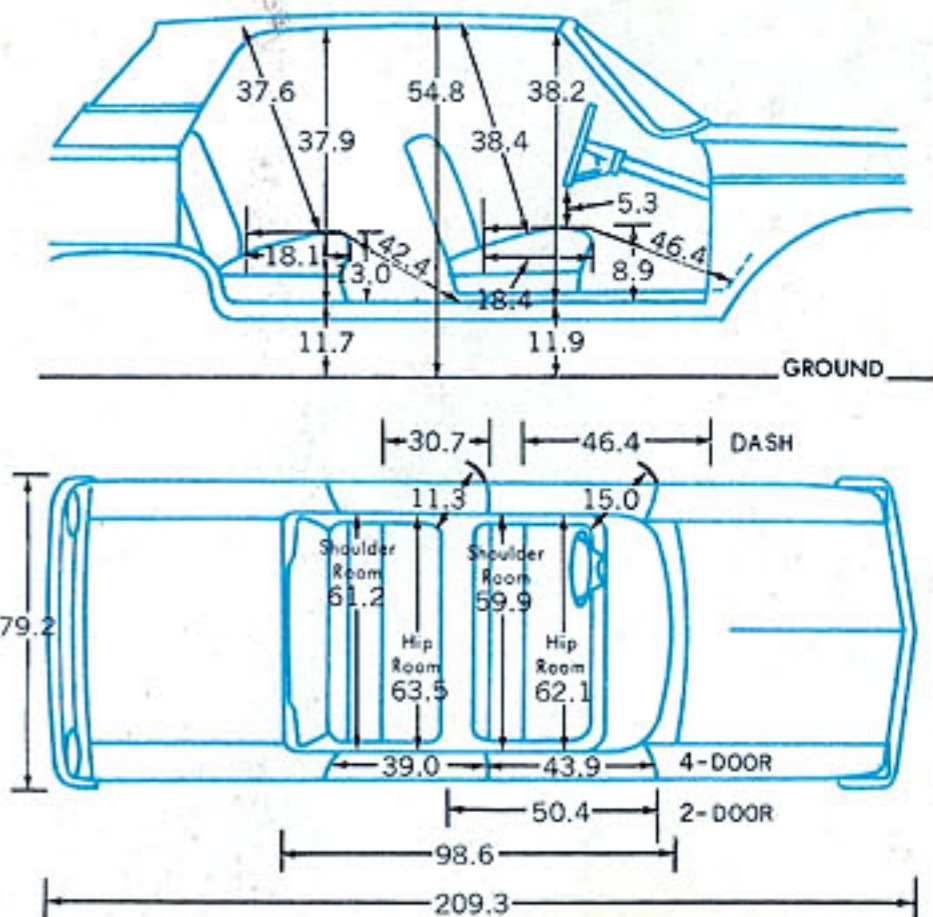

STATION WAGON DIMENSIONS*

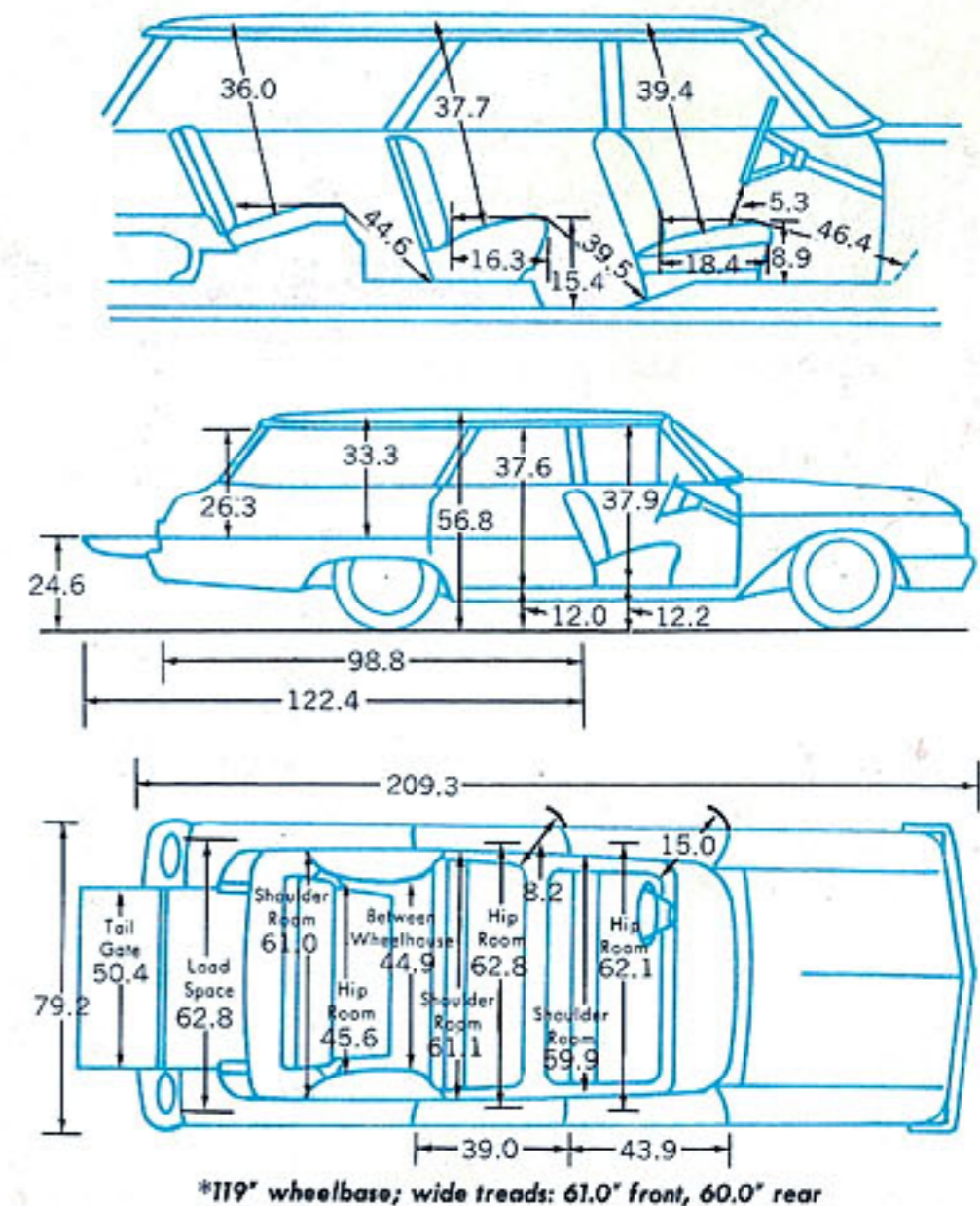

*119" wheelbase; wide tracks: 61.0" front, 60.0" rear



The Ford Quality Control system, a Ford first, results in products of highest quality. All manufactured parts pass rigid dimensional, laboratory and durability tests. Quality Control teams also select cars from each shift at every assembly plant for an exhaustive search for any deviations from strict engineering specifications.

Comparative information in this catalog was obtained from authoritative sources, but is not guaranteed. The specifications contained herein were in effect at the time this catalog was approved for printing. Ford Division of Ford Motor Company reserves the right to discontinue models at any time, or change prices, specifications or design without notice and without incurring obligation.

PRODUCTS OF  MOTOR COMPANY

Compliments of

your friendly FORD DEALER