

1972 CHRYSLER

IMPERIAL · NEW YORKER BROUGHAM · NEW YORKER · TOWN & COUNTRY · NEWPORT CUSTOM · NEWPORT ROYAL

A commitment to quality

We believe the '72 Chrysler is our finest ever. We are proud of the quality that we have built into every Chrysler. You expect a new car, especially a luxury car, to perform well for a long time. The 1972 Chryslers are intended to be that way. That's why we believe our cars are the finest ever. We're confident you will find them that way, too. Try one, we think it will give you all you demand of a fine car.

The people who build the
1972 Chryslers

1972 Chryslers—

Coming Through With Luxury That Lasts

Luxury that lasts is a pretty bold promise. But it's one we feel we come through on because we spent a lot of time designing and engineering the 1972 Chrysler to perform well for a long time. That's not to say we didn't change the looks any. We did. But it was to make your Chrysler better by giving it a smoother shape.

We've always been proud of our reputation for engineering. We work at it because there's a lot more to a luxury car than status. The luxury car should get you around in maximum comfort and luxury. It should give you more room than lesser cars. Handling must be effortless but precise. And it should carry a host of standard features. Read on and see how the 1972 Chryslers come through with the kind of car America wants.

About the new looks

New Chrysler styling reflects a smooth look. New split grilles are inset in rugged loop-type front bumpers. Taillights have been incorporated into the massive full-width rear bumper. Body side protection moldings are standard on all Chryslers.

The "Nuts and Bolts"

We did a lot of things you don't see to make these '72s better. There's a huskier new steering knuckle up front. About the TorqueFlite automatic transmission. It's a recognized leader in its field. But we improved a seal to make it last longer. There's a new overrunning clutch for better gear meshing, quieter shifting and reduction of transmission overload. Then there's our new electronic ignition system. Standard on Imperial and available at extra cost on all engines. It has no breaker points or condenser—less to replace at tune-up time. The ignition also improves spark plug life when you use low-lead gasoline. Another example of giving you more: we're using a new micro-cracked chrome plating process on some exterior chrome. It keeps it looking shiny for a long time. These are a few things we've done to make Chrysler luxury last longer.

Newport Royal standard features.

400 cubic inch 2-barrel V-8 engine • Single exhaust system • 37-amp alternator • 59 amp/hr. battery • Torsion-Quiet Ride • H78 tires • TorqueFlite automatic transmission with part-throttle kickdown • Power steering • Power brakes, front disc and self-adjusting rear drums • Speedometer-odometer-trip-ometer-fuel gauge • Alternator gauge • Oil pressure indicator, coolant temperature and high-beam indicator lights • Heater/defroster with four blower speeds • 2-speed windshield wipers with coordinated washers • Lockable glove box • Inside hood release • Litter container • Color-keyed formed carpet • Lighted front ashtray • Two rear seat ashtrays • 12" inside day/night mirror • Ventless door glass • Loop-type bumpers integrated with body styling • Wheel covers • Dual horns • Body side molding • Partial front wheel lip molding • Drip molding • Bright rear window moldings.

Newport Custom standard features.

All of the above with the following additions and changes: Newport Custom exterior identification • Belt molding • Door upper frame moldings on 4-door sedan • Front center armrest • Air foam seat cushions • Seat side shields • Vinyl side protective molding • Full wheel opening lip moldings, front and rear.

Town & Country standard features.

All the above with the following additions and changes: Simulated wood appliqué on body sides • Hardtop-style tailgate can be opened as a door with window raised • Power Auto-Lock, locks tailgate when ignition is "on" • Roof air deflector • Power tailgate window • Rear wheel opening skirts • Sound absorbing interior headlining • Large diameter front anti-sway bar • Heavy-duty rear springs • All-vinyl interior • Concealed storage compartments in rear wheel housing covers • L84 tires.

New Yorker standard features.

All of the Newport features with the following additions and changes: 440 cubic inch 4-barrel V-8 engine • Trunk light • Electric clock • Hood insulator pad

• Fully-carpeted trunk • Color-keyed seat belts • Undercoating • J78 tires • Front wheel lip moldings • Double full-length body side moldings with color-keyed vinyl protective insert • Rear bumper periphery moldings • Rear deck lid lock cover • Remote control outside left rearview mirror • Glove box light • Right and left instrument panel ashtray lights • Map light • Rear quarter wheel opening skirts.

New Yorker Brougham standard features.

All of the New Yorker features plus: Power windows • 50/50 front seat with dual folding center armrests and reclining passenger seat on 4-door models, bucket seats with single folding center armrest, automatic seat-back release and passenger recliner on 2-door • Rear seat center armrest • Console-type armrests on all doors • Fender-mounted turn signals located in fender top moldings • Low fuel warning light • Headlights-on warning signal • Headlight time-delay switch • Rim-Blow steering wheel • Automatic seat-back release on 2-door • 3-speed windshield wipers with coordinated washers.

Imperial standard features.

440 cubic inch 4-barrel V-8 engine • Electronic ignition • TorqueFlite automatic transmission with part-throttle kickdown • Torsion-Quiet Ride • Power steering • Power brakes, front disc and self-adjusting rear drums • Power windows • Vinyl roof • Formal rear window with color-keyed vinyl moldings • Assist straps on inside rear roof pillar, 4-door model • Vinyl-covered rear pillar pillows, 4-door model • Rear reading lights • Instrument panel gauges for: Alternator, coolant temperature, oil pressure and fuel level • Tripometer • Electric clock • Reminder lights for "fasten seat belts," "lock doors," "brakes" and "high beam" • Color-keyed safety belts • Sentry signal for monitoring gauges • Courtesy map, glovebox lights • Ignition switch light with time-delay • Air conditioning with fresh air heater/defroster • Tinted glass • Argent paint-filled fender top moldings with turn signal indicators • Body side molding with color-keyed vinyl insert

• Front wheel lip moldings with color-keyed paint insert • Rear wheel opening skirts with color-keyed lip moldings • Imperial medallion on hood and deck • Rear side marker lights are illuminated Imperial shields with eagle • Cornering lights • Periphery moldings around bumpers and taillights • 100% cut-pile nylon carpeting • Cloth-and-leather split-back bench seat with automatic seat-back release on 2-door hardtop • 50/50 split bench seat with individual adjustment, folding center armrests and passenger recliner in cloth-and-leather, standard on 4-door hardtop • Vinyl headlining • Simulated wood appliqué on doors, clock, glove box and instrument cluster face • Storage compartments, all doors • Rim-Blow steering wheel • Four cigar lighters • Concealed 3-speed wipers coordinated with electrically-operated washers • Inside hood release • Undercoating and hood silencer pad • 70 amp/hr. battery • 12" inside day/night mirror • Remote control left outside rearview mirror • All Imperials road-tested before shipping to assure greater customer satisfaction.

Standard safety features.

On all Chryslers: Large rear reflectors and lights • Back-up lights • Fuel-tank impact protection • Lane-change turn signal • Locking steering column • 3-point seat belt anchorage • Energy-absorbing steering column and wheel • Energy-absorbing and padded instrument panel • High-strength windshield • Energy-absorbing front seat-backs and armrests • Seat belts, all places • Two front shoulder belts • Manual door locks—levers with non-override lock feature, except driver's door • Interlocking door latches • Flush-type inside door release levers • Cushioned sun visors • Dual braking system with warning light • Side marker lights • Hazard warning light system • Electric windshield wipers • Vinyl-clad day/night inside rearview mirror on double-ball-joint mount • Two front head restraints • Locking latch on front seat-backs, 2-door models • Left outside rearview mirror • Bias-belted tires.



Imperial LeBaron 4-Door Hardtop



New Yorker Brougham 2-Door Hardtop



New Yorker 4-Door Hardtop



Town & Country Wagon



Newport Custom 4-Door Sedan



Newport Royal 2-Door Hardtop

	Wheelbase	Track		Length	Width	Height	Head Room		Seat Height		Leg Room		Shoulder Room		Knee Room
		Front	Rear				Front	Rear	Front	Rear	Front	Rear			
Imperial (4-Door Hardtop)	127	62.4	63.4	229.5	79.6	56.0	38.3	37.0	9.0	11.5	41.9	41.2	62.7	62.7	6.9
Town & Country (2-Seat & 3-Seat)	122	62.1	63.4	224.8	79.4	57.4	39.6	40.2	9.2	11.9	41.8	39.1	63.2	62.7	5.2
New Yorker Brougham, New Yorker, Newport Custom & Newport Royal (4-Door Hardtops)	124	62.1	63.4	224.1	79.4	*	38.1	37.0	9.2	11.5	41.8	41.5	63.2	63.3	7.5

*New Yorker Brougham—55.4, Newport Custom—55.2, Newport Royal—55.0

As the buyer of a luxury car, you expect more. You demand the best in styling, comfort, ride, room and standard features. You also look for the finely-executed details like passenger assist straps and rear reading lamps. Our goal in building Imperials is to build a better luxury car than anyone else. We spend a lot of time making sure we come through with the kind of car you want. But when it comes to buying a luxury car, you want to know exactly what you are getting. Learn about the best, take a demonstration drive in a 1972 Imperial. You'll understand then what we mean about coming through.

MINI COOPER SPECIAL

CHRYSLER





Imperial LeBaron 2-Door Hardtop



IMPERIAL LeBARON 2-DOOR HARDTOP

Luxury cars should look like luxury cars. They also should stay looking like luxury cars for a long time. That's what was on our minds when we gave the 1972 Imperials new styling. It starts with a bold, new grille and hidden headlights surrounded by a new massive loop-type front bumper. Body lines have been smoothed out and the new hardtop roofline shows a slim silhouette. There's a new big rear bumper with bumper guards. Some fine "touches": wheel lip moldings and rear window and vinyl roof moldings are color-keyed.



Imperial LeBaron 4-Door Hardtop



IMPERIAL LeBARON 4-DOOR HARDTOP

Imperial luxury goes far deeper than a beautiful body—like Torsion-Quiet Ride for instance. It's standard on all Chryslers and Imperials to give you a stable, smooth, quiet ride. Imperial is powered by our biggest engine, the 440 cubic inch 4-bbl. V-8. And that engine has our new electronic ignition which eliminates breaker points and condenser. It means fewer ignition tune-ups, more reliability for you. Other Imperial standard features: air conditioning, tinted glass, power windows and power radio antenna with optional radios.



IMPERIAL INTERIORS

Imperial's inside story is told with finely-executed luxury. Supple Cologne leathers and luxuriant Calais and Icarus cloths cover deeply-padded seats. Power windows are standard. The look of rosewood graces instrument panel, driver's console, doors and passenger assist handles. Door-operated courtesy lights show the way. Switch-operated reading lamps hide in the rear roof pillar of 4-door hardtops ready to provide convenient light shielded from the driver.

A. Imperial's standard 4-door 50-50 split-bench seat in Cologne leather and Icarus cloth, available in blue, green, gold, tan, parchment and black. Driver and passenger seats adjust individually. The passenger seat reclines to a wide variety of positions. Note the individual folding center armrests for driver and passenger.

B. Optional split-bench seat in Cologne leather available on 4-door models. This all-new, ultra-plush seat features a "floating cushion." This seat is fashioned in the style of fine furniture. Shown in gold, it also comes in blue, green, tan, parchment, black and white.

C. Optional leather bucket seats provide maximum individual comfort on 2-door hardtops. Passenger seat reclines. Color availability: black, green, gold, blue, tan and white.

D. Standard 2-door cloth-and-leather split-bench in green. Note center armrest has wide, deeply-padded surface for driver and passenger. Also available in blue and black.

E. Imperial's instrument panel has been designed to be functional and beautiful.



B



C



D



E

There's a lot more to a big car than bigness. You buy it for ride, comfort, luxury, quality and standard features you can't find on other cars. We think our Chryslers are the best of the big ones because we build them to be best. This year, we strived to improve the things you count most important, durability and quality. And we took special pains with quality. We made these improvements on every Chrysler, from the plushiest New Yorker Brougham to the Newport Royal, your low-cost introduction to Chrysler. We think the improvements we made will convince you we're coming through with the kind of car you want.

CHRYSLER

NEW YORKER BROUGHAM · NEW YORKER · TOWN & COUNTRY · NEWPORT CUSTOM · NEWPORT ROYAL



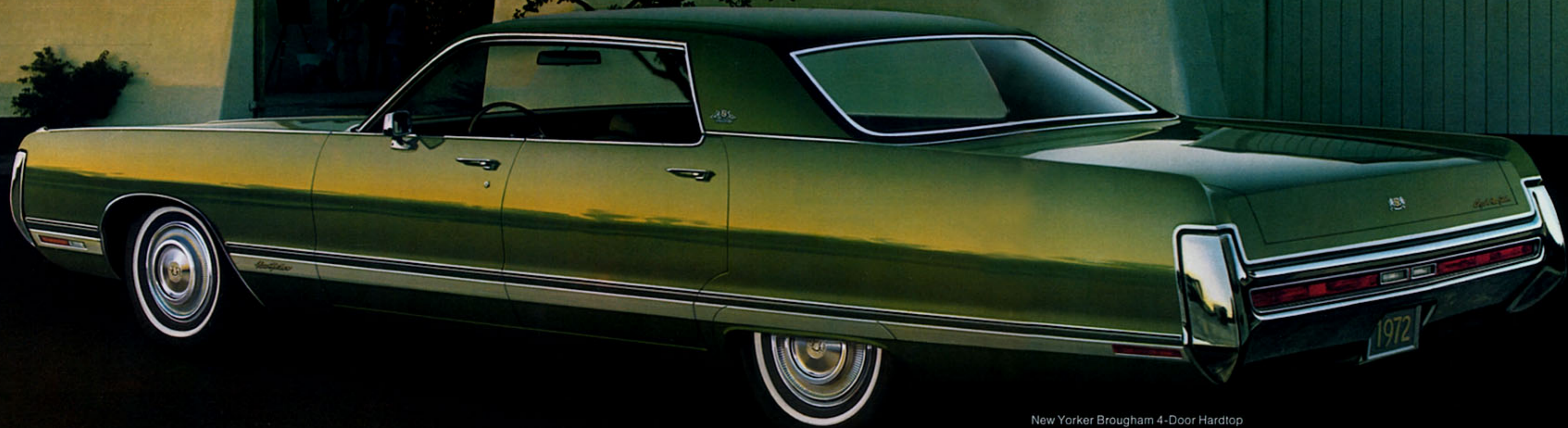

New Yorker Brougham 4-Door Hardtop



NEW YORKER BROUGHAM

New for '72, New Yorker Brougham is the most luxurious Chrysler. It has a split grille recessed in the solid loop-type front bumper. The rear bumper wraps around the rear of the quarter panels. Body lines are smooth and flowing with character line capped by a double full-length side molding with color-keyed vinyl insert in the upper molding for parking lot protection. Fender top moldings house turn signal indicators. Roofline of the 4-door hardtop has been designed to give a trim look complementing the aerodynamic body styling. New Yorker Brougham also is available as a 4-door sedan or a 2-door hardtop.



New Yorker 4-Door Sedan



New Yorker 2-Door Hardtop



NEW YORKER

Luxury has to be engineered into a car and the '72 Chryslers reflect our best efforts. New Yorker for instance; body and frame have been welded into one unit to reduce squeaks and rattles. That means quiet and in today's blaring noise, quiet is important. To really keep things hushed up: nearly 250 square feet of sound insulation throughout. It's all part of what we call Torsion-Quiet Ride. Luxury means "extras" that are standard. Try these: 440 cubic inch V-8, TorqueFlite automatic transmission, power steering, power brakes with front discs and self-adjusting rear drums. New Yorker models: 2-door hardtop, 4-door hardtop, 4-door sedan.



NEW YORKER BROUGHAM & NEW YORKER INTERIORS

New Yorker Brougham, our newest Chrysler, has an interior that sets a new standard of elegance. A heavy-weave Casino cloth and Cologne vinyl covers the standard 50-50 split-bench front seat on 4-door models. This seat has dual folding center armrests. Cologne vinyl covers the standard bucket seats on the 2-door. All models have rear seat center armrests, power windows, console-type armrests on all doors and distinctive New Yorker Brougham ornamentation. New Yorker keeps up its reputation for fine interiors with a standard bench seat handsomely finished in Canterbury cloth and Cologne vinyl. Optional seats are available in Ranger and Bancroft vinyls.

A. The standard cloth-and-vinyl 50-50 split-bench seat of the New Yorker Brougham 4-door models with reclining passenger seat. Available in blue, green, gold, parchment and black. Also available in all-vinyl in blue, green, black and tan.

B. The standard vinyl bucket seats of the New Yorker Brougham 2-Door Hardtop are in green, tan, black and white with appropriate exterior colors.

C. Standard New Yorker 4-door cloth-and-vinyl bench seat in parchment, also available in blue, green, gold and black, with appropriate body colors. This seat is available in vinyl in green, gold and black.

D. Optional bucket seats on the New Yorker Hardtops in Bancroft vinyl colors of green, black and white with black accent.

E. Standard New Yorker 2-door bench seat with center armrest, in cloth-and-vinyl is available in green, gold, black, parchment and blue. This seat may be ordered in vinyl in black, gold and green.

F. New Yorker Brougham instrument panel with Rim-Blow steering wheel. On this and all Chrysler instrument panels, our design puts information before the driver for quick viewing.



B



C



D



E



F



Town & Country Wagon



TOWN & COUNTRY

The complete wagon. New looks make it so with loop-type front bumper surrounding dual horizontal headlights, new simulated wood-grain appliqué on body sides, new rear wheel opening skirts. A new optional vinyl roof allows you to dress things up formally. There's a new standard engine—our 400 cubic inch V-8—to give you the hauling power you'll need. We've also put a larger anti-sway bar in the front suspension and improved rear spring rates for a more stable ride.



TOWN & COUNTRY INTERIORS

Our description of the Town & Country as "the complete wagon" is especially appropriate inside. It's beautiful, tough and roomy.

Rugged Cologne vinyl covers the standard split-back seats with center armrests (you can order 2-seat or 3-seat models).

Deep-pile nylon carpeting covers the floors and load area. There's 113.2 cubic feet of storage space in the two-seat version, including a lockable hidden compartment under the rear floor. You get a host of standard features like power Auto-Lock for the tailgate. It locks the gate any time the ignition is on. Others include: power tailgate window, rear wheel opening skirts, new improved sound-absorbing headliner, larger diameter front anti-sway bar, storage compartment in rear wheel housing covers, and more.

A. Town & Country's standard bench seat with folding center armrest—Cologne vinyl in blue, green, tan and black.

B. The optional 50-50 split-bench seat with passenger recliner. Available in Cologne vinyl in blue, green, tan and parchment. Also available is Calais cloth and Coachman vinyl in green and parchment.

C. Convenient step pad is built into the rear bumper.

D. Chrysler's highly-functional roof air deflector is standard. When you order Town & Country with an optional vinyl roof, the air deflector is color-keyed to match the roof.

E. Optional rear assist handles make it easier to get in and out.

F. Dual Auto-Temp II air conditioning is available. Designed specially for Town & Country, this unit provides maximum comfort throughout the passenger and load area.

G. Town & Country opens up a new way this year with its Three-Way Tailgate. You can open it as a door or gate with window down *and* you can open it as a door with the glass up thanks to its hardtop design.

H. Optional vinyl roof, available in black or tan. Also shown is the popular optional luggage rack.





Newport Custom 4-Door Hardtop



NEWPORT CUSTOM

Newport Custom's styling is enhanced by distinctive full-length body side molding with color-keyed vinyl insert, front and rear wheel lip moldings and rear bumper and taillight periphery moldings. Our newest engine, the 400 cubic inch V-8, is standard. Our Torsion-Quiet Ride on this and all Chryslers provides the best ride we can offer. Add optional air conditioning, an AM/FM radio, perhaps, and you're set for many miles of pleasure.



Newport Custom 4-Door Sedan



Newport Custom 2-Door Hardtop



NEWPORT CUSTOM

Big is a byword for '72. Newport Custom stretches over a 124 inch wheelbase. It carries one of the roomiest interiors in its class. Trunk room to spare, with 21.2 cu. ft. of space you will be hard pressed to fill. There's our new wider stance, too—the rear wheels have been moved 1.4 inches wider. It gives Chrysler a lower wider look.



Newport Royal 2-Door Hardtop



NEWPORT ROYAL

Newport Royal is our lowest price Chrysler but it's all Chrysler. It gives you all the things you'd want in a big car. Roomy inside, big outside and a huge trunk. And think about these standard features: 400 cubic inch V-8 engine that burns regular gas, TorqueFlite automatic transmission, Torsion-Quiet Ride, power steering, power brakes with front discs and self-adjusting rear drums, unibody construction, Sound Insulation System and many more. This is no junior edition Chrysler.



Newport Royal 4-Door Hardtop



Newport Royal 4-Door Sedan



NEWPORT ROYAL

We started this catalog by telling you the 1972 Chrysler features luxury that lasts. That applies to all Chryslers—even Newport Royal, our most affordable one. We have devised a number of new quality control checks to make sure Chryslers last. One is new test equipment to check front suspension ball-joint studs and steering knuckles. Another is a computerized check of our TorqueFlite automatic transmissions. Another is a system to check electrical circuits in our Chryslers during assembly. Like we said, we want your Chrysler luxury to last.



NEWPORT CUSTOM/ NEWPORT ROYAL INTERIORS

Newport Custom offers you four plush interior choices, starting with a standard bench seat in Calais cloth and Coachman vinyl and ranging up to a split-bench seat with passenger recliner in Coachman vinyl. Newport Royal protects its reputation as a top buy in its class with three rich, durable interiors. Standard is the bench seat in Concord cloth and Coachman vinyl. All Newport Custom and Newport Royal models feature carpeting throughout in complimentary colors.

A. Newport Custom's standard Calais cloth and Coachman vinyl bench seat with folding center armrest, shown in blue.

Also available in green, gold, parchment and black. Available in vinyl in green, gold, parchment and black.

B. Newport Royal 2-door hardtop optional bucket seats in Bancroft vinyl come in black or white with black accent.

C. The optional 50-50 split-bench seat for Newport Custom with passenger recliner for 4-door models. It is available in Cologne vinyl in black or in Coachman vinyl and Calais cloth in green, parchment and black.

D. Newport Royal's standard cloth-and-vinyl bench seat in blue, also available in green, gold, parchment and black.

E. Optional Ranger vinyl bench seat for Newport Royal in gold. Also may be ordered in green, parchment and black.



ENGINES

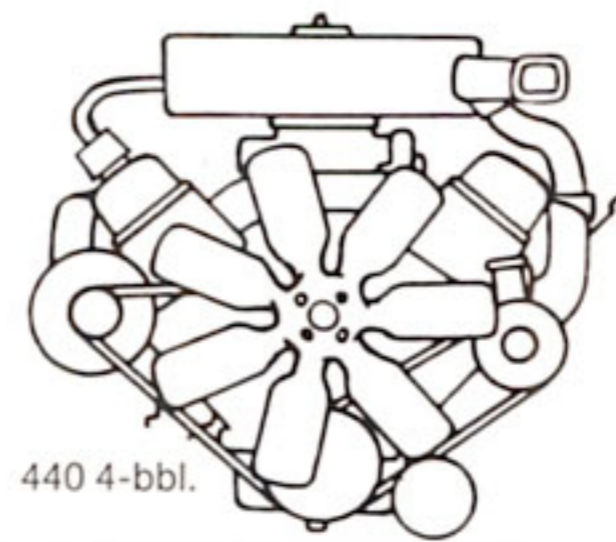
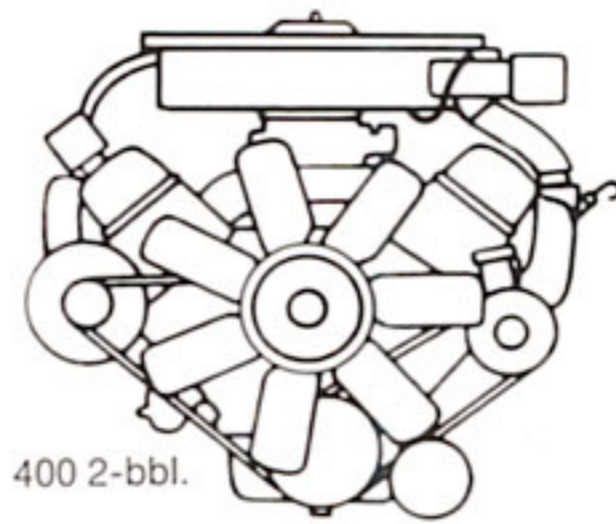

Displacement	Carburetion	Comp. Ratio	Air Cleaner	Exhaust System	Newport Royal	Newport Custom	New Yorker	Town & Country	New Yorker Brougham	Imperial
400	1, 2-bbl.	8.2	Silenced	Single	Std.	Std.	—	Std.	—	—
440	1, 4-bbl.	8.2	Silenced	Single	Opt.	Opt.	Std.	Opt.	Std.	Std.
440d	1, 4-bbl.	8.2	Silenced	Dual	Opt.	Opt.	Opt.	—	Opt.	—

d—dual exhaust engine.

Torsion-Quiet Ride

A. Torsion bars twist and flex to help shield you from road shock.
 B. Rubber sound isolators help separate chassis noise from the rest of the car.
 C. Unibody construction has about 4,200 individual welds to help provide strength and silence.

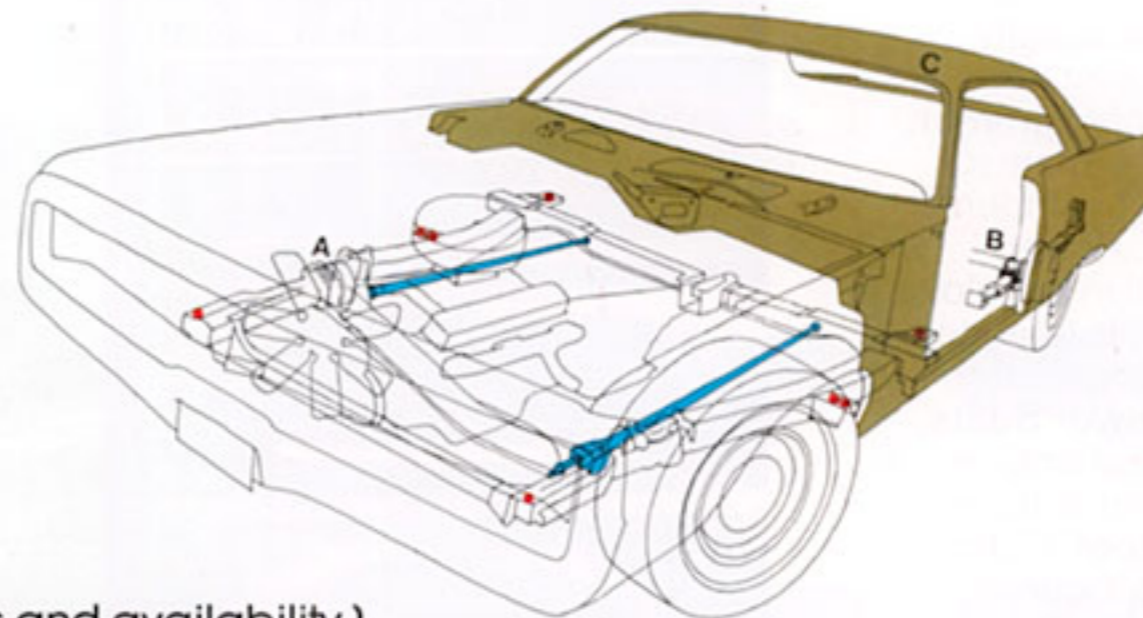

1972 Options (Check your salesman for additional options and availability.)

Options	Newport Royal	Newport Custom	New Yorker	Town & Country	New Yorker Brougham	Imperial	Options	Newport Royal	Newport Custom	New Yorker	Town & Country	New Yorker Brougham	Imperial
Air Conditioner—single manual	O	O	O	O	O	S	Radio—AM	O	O	O	O	O	NA
Air Conditioner—dual manual	NA	NA	NA	O	NA	NA	Radio—AM 8-track tape	O	O	O	O	O	NA
Air Conditioner— Single Auto-Temp II	O	O	O	O	O	O	Radio—AM/FM Search Tune	O	O	O	O	O	O
Dual Auto-Temp II	NA	NA	NA	O	NA	O	Radio—AM/FM Multiplex Stereo	O	O	O	O	O	O
Auto-Speed Control	O	O	O	O	O	O	Radio—AM/FM Multiplex & 8-track tape	NA	NA	NA	NA	NA	O
Sure Brake—4-wheel anti-skid braking	NA	NA	NA	NA	NA	O	Radio—AM/FM Multiplex Stereo Cassette Tape	O	O	O	O	O	O
Deck Lid Release	O	O	O	NA	O	O	Microphone (dealer inst.)	O	O	O	O	O	O
Rear Window Defogger ¹	O	O	O	NA	O	O	Safeguard Sentinel	O	O	O	O	O	O
Defroster—rear window and rear seat heater ²	O	O	O	NA	O	O	Shoulder Belts—rear (dealer installed)	O	O	O	O	O	O
Sure-Grip Differential	O	O	O	O	O	O	Tinted Glass	O	O	O	O	O	S
Door Guards—2-doors	O	O	O	NA	O	O	Rim-Blow Steering Wheel	O	O	O	O	S	S
Door Guards—4-doors	O	O	O	O	O	O ³	Tilt & Tel. Steering Wheel (with Rim-Blow)	O	O	O	O	O	O
Automatic Headlight Dimmer	NA	NA	NA	NA	NA	O	Vinyl Roof	O	O	O	O	O	S
Mirror—outside right	O	O	O	O	O	O ³	Trailer-Towing Package	O	O	O	O	O	O
Molding—vinyl body side	O	S	S	O	S	S	Whitewall Tires	O	O	O	O	O	O
Power Seat—bench	O	O	O	O	NA	O ⁴	Sun Roof	O	O	O	NA	O	O
Power Seat—left (bucket and 3-in-1 seats)	O	O	O	O	O	O	High-level Ventilation	O	O	O	O	O	NA
Power Seat—left & right (bucket and 3-in-1 seats)	O	O	O	O	O	O ⁵	Road Wheels	O	O	O	NA	O	NA
Power Vent Windows (4-Door Hardtops)	NA	NA	O ⁶	NA	O ⁶	O	Deep Dish Wheel Covers	O	O	O	O	O	NA
Radio Antenna—power	O	O	O	O	O	O ⁷	Wheel Opening Skirts	O	O	S	S	S	S
							Spare Tire Cover	NA	NA	O	NA	O	O ³
							Power Windows	O	O	O	O	S	S

O—Optional S—Standard NA—Not Available 1—NA with rear seat heater 2—NA with rear window defogger 3—Available in package only
 4—2-door models only 5—Required with bucket seats 6—With tinted glass and power windows only 7—S with optional radio

OPTIONS FOR LASTING LUXURY.

Multiply Chrysler and Imperial luxury with your choices. There is a model application chart on the next page of this catalog. Your dealer can give you the latest information on availability.

- 1. Tilt & Telescope Rim-Blow Steering Wheel.** Adjust the wheel to your position. Squeeze the rim to blow horn.
- 2. Auto-Speed Control.** A fingertip control in the turn signal lever sets cruising speed and maintains it automatically until you brake or accelerate.
- 3. Automatic Headlight Dimmer.** Dims lights and returns them to high beam. Available on Imperial.
- 4. Deck Lid Release.** Power-operated via a control in the glove box.
- 5. Auto-Temp II.** Is intended to keep the interior temperature where you set it.
- 6. Power Seats.** Available for driver seat only or both front seats with buckets or split-bench.
- 7. Sun Roof.** Catch rays whenever you can with this option.
- 8. Road Wheels.** Set of four to enhance the styling of your Chrysler.
- 9. Wheel Covers.** New-look wheel covers dress up your Chrysler completely.
- 10. AM/FM Multiplex Stereo and Cassette Tape Accessory.** Allows you to take along your favorite music. An optional microphone for dictating is dealer-installed.
- 11. Rear Window Defogger.** Helps keep the rear window free of mist while you drive.





Charcoal Metallic



Rallye Red



Blue Sky



Chestnut Metallic



Amber Sherwood Metallic



Burnished Red Metallic



True Blue Metallic



Spinnaker White

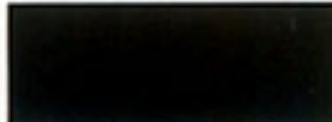

Formal Black



Evening Blue Metallic



Sun Fire Yellow



Sherwood Green Metallic



Honeydew



Sahara Beige



Gold Leaf Metallic



Coral Turquoise Metallic



Tawny Gold Metallic

Coming Through with the kind of car America wants.



Imperial LeBaron 2-Door Hardtop



Imperial LeBaron 4-Door Hardtop



New Yorker Brougham 2-Door Hardtop



New Yorker Brougham 4-Door Hardtop



New Yorker Brougham 4-Door Sedan



New Yorker 2-Door Hardtop

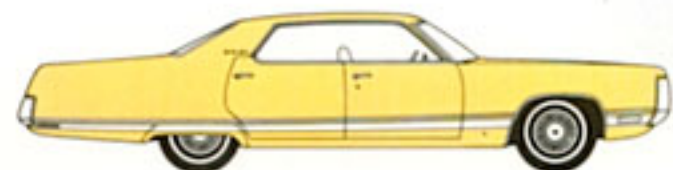

New Yorker 4-Door Hardtop



New Yorker 4-Door Sedan



Town & Country Wagon
(available with 2 or 3 seats)



Newport Custom 2-Door Hardtop



Newport Custom 4-Door Hardtop



Newport Custom 4-Door Sedan



Newport Royal 2-Door Hardtop

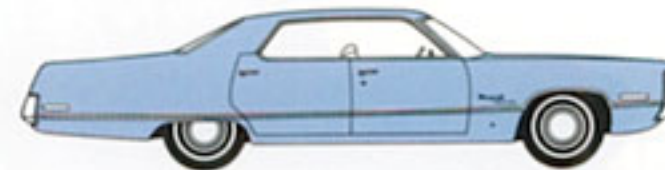

Newport Royal 4-Door Hardtop



Newport Royal 4-Door Sedan

All product illustrations and specifications are based on authorized information. Although descriptions are believed correct at publication approval, accuracy cannot be guaranteed. Some of the equipment shown on product illustrations is optional, at extra cost. Chrysler Motors Corporation reserves the right to make changes from time to time, without notice or obligation, in prices, specifications, colors and materials, and to change or discontinue models. Specifications and product descriptions apply to North American-built vehicles only.

CHRYSLER



Keep your Chrysler coming through in top condition. Service it with the men who know it best. See your Chrysler-Plymouth Dealer.

