

DODGE '73

MONACO · POLARA · CHARGER · CORONET · CHALLENGER · DART





For the past 59 years, Dodge has been known for innovative engineering. 1973 is no exception.

"Were they so disposed, Dodge Brothers could not lower the quality of their products . . . because public opinion has established a standard for everything bearing their name. And . . . the public expects constant improvement of any product in which they repose supreme confidence."

This excerpt taken from a Dodge car catalog written in 1919 represented the Dodge Brother's early attitude about building automobiles. And it still represents Dodge Division's attitude today. Through the years, Dodge has pioneered such innovations as the four-door sedan in 1919 . . . a full front seat in 1921 . . . a hand-operated windshield cleaner in 1921 . . . and the industry's first all-steel coupe body introduced in June, 1922.

AND TODAY:

In 1973, Dodge comes on strong with a host of meaningful engineering advance-

ments. The Electronic Ignition System is standard on all Dodge six-cylinder and V8 engines this year. With no points to wear out and no condenser to replace, this system reduces the frequency of resetting ignition timing under normal conditions. By eliminating the major cause of misfiring, it also reduces resultant engine emissions. A new high-speed starter for improved starting is standard this year on models with the 360, 400, or 440 V8 engine.

CLEANER AIR, ANYONE?

The list of new and improved emission control features on the 1973 Dodge engines is an imposing one. Dodge's Cleaner Air System (CAS), developed over the years, effectively reduces the levels of hydrocarbons, carbon monoxide, and oxides of nitrogen. Other new and worthwhile advances in Dodge's quest for cleaner air include the electric assist choke . . . the exhaust gas

recirculation system (EGR) . . . proportional exhaust gas recirculation (PEGR) . . . and the orifice spark advance control (OSAC). These items are all standard on all Dodge engines for 1973.

NOW HEAR THIS.

An electronic Security Alarm System is available on all '73 Monacos and Polaras. Tampering with the hood, doors, or trunk lid causes the headlights, taillights, and side marker lights to flash in conjunction with a pulsing of the horn. The alarm continues as long as the violation exists or until shut off with the ignition-door key. It then rearms itself automatically. The system is camouflaged and is built into your car's regular wiring system to thwart tampering.

SILENCE, PLEASE.

All 1973 Dodges offer major chassis and interior improvements to reduce interior noise levels. What's more,

Charger and Coronet now offer Dodge's famous Torsion-Quiet Ride. This is a sophisticated suspension system which helps isolate the passenger compartment from road and engine noises through the use of strategically located rubber mounts, extra padding, and other insulation materials. Charger SE goes a step further with a premium silencing package that indeed makes it a super quiet car.

AND THERE'S MORE, LOTS MORE.

An extra-protection bumper system, improved windshield wipers, and a new sliding metal sun roof are but a few of the many new items you'll find detailed inside. So read on. We'll be surprised if you're not surprised with all that's new and exciting with Dodge.

EXTRA CARE IN ENGINEERING MAKES A DIFFERENCE IN DODGE . . . DEPEND ON IT.

INDEX

Introduction	2-3
Monaco	4-5-6-7
Polara Custom	8-9
Polara	10-11-12-13
Charger SE	14-15
Charger	16-17-18-19
Coronet	20-21-22-23
Challenger	24-25
Dart Swinger & Custom	26-27
Dart Sport	28-29
Dart	30-31
Station Wagons	
Monaco/Polara	32-33
Coronet	34-35
Sportsman	36
Trailer-Towing Packages	37
Safety Features	37
Options & Colors	38-39
Model Lineup	40 (Back Cover)

Monaco. The big Dodge that's creating a quiet sensation.

Over the years, the Dodge Monaco has gradually been undergoing subtle changes and improvements in style and design. As a result, its popularity continues to grow. Another reason for its growing sales success is the feeling of satisfaction derived from owning a Dodge Monaco, one of the roomiest and most comfortable cars on the road regardless of price. A close examination of this handsome beauty will suggest several more good reasons. Hidden headlights. New, stronger bumper guards. And a sleek profile that is unmistakably Monaco. Inside, Monaco offers such luxury items as deep-pile carpeting, a rich-looking cloth-and-vinyl seat and a fold-down center armrest. Add Monaco's Torsion-Quiet Ride, and you have one of the finest luxury cars on the market.

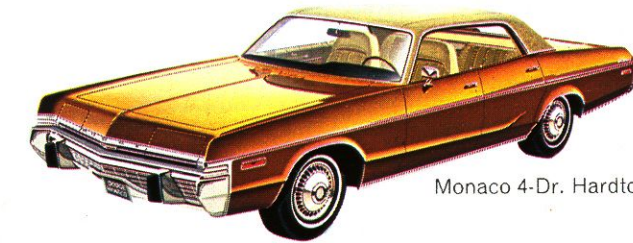

Monaco 4-Dr. Hardtop.



Monaco 4-Dr. Sedan.



Monaco 2-Door Hardtop



Monaco's luxurious Dakar cloth-and-vinyl interior.

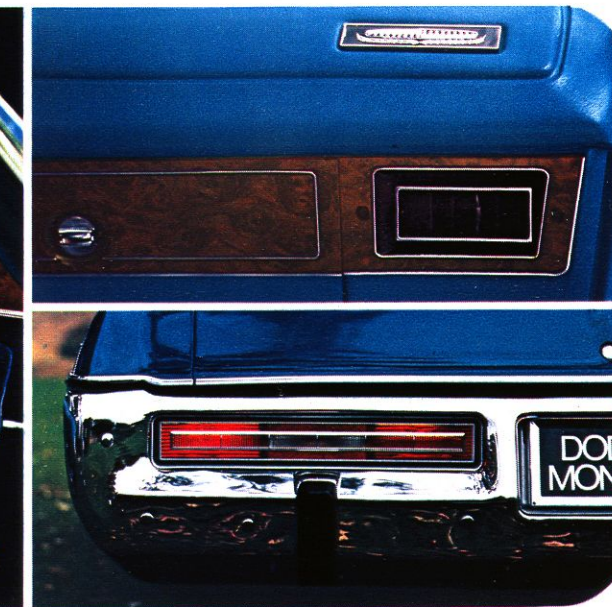

Handsome burl walnut trim accent. Monaco's all-new rear-end design.



A This handsome split-bench seat and fold-down center armrest in sculptured Bancroft and Coachman vinyl is optional on all Monaco sedans and Monaco hardtops, standard on all Monaco station wagons.

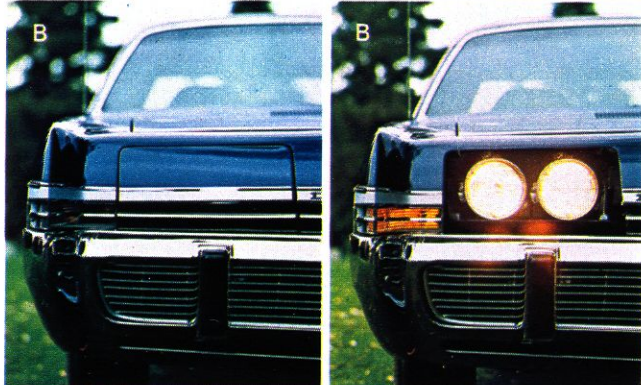

B Monaco's concealed headlights are out of sight during the day . . . ready for action as twilight approaches.

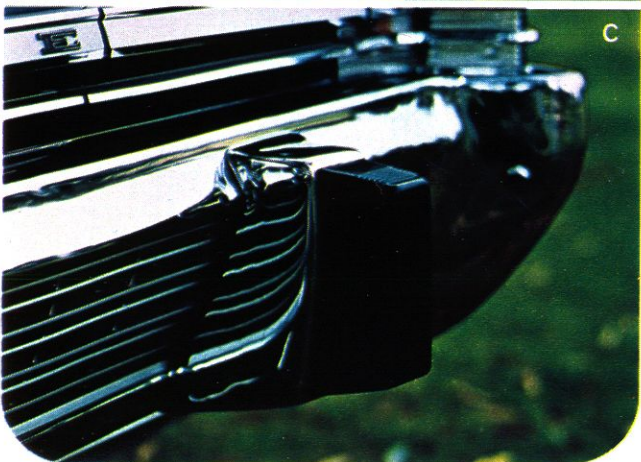

C Standard front and rear bumper guards add a nice styling touch to Monaco's extra-protection bumpers.



For those who insist on our best: Monaco Brougham.

The Brougham Package is available on four-door Monaco hardtops and sedans, and includes the following items: Vinyl roof with "Brougham" nameplate • 50/50 cloth-and-vinyl front seat with passenger-side recliner • Fold-down center armrest in rear seat • Cornering lights • Carpeted trunk and spare tire cover • Sill and sill extension mouldings.



Monaco Brougham 4-Dr. Sedan.

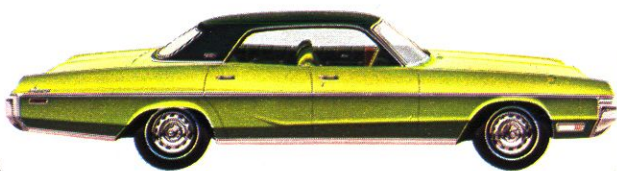

Monaco Brougham 4-Dr. Hardtop.

The big Dodge – the harder you use it, the more you'll appreciate the character built into it.

ANTITHEFT PROTECTION

Dodge's electronic Security Alarm System is available on all 1973 Polaras and Monacos to help thwart tampering. The system is armed by locking either front door with the ignition key. ■ Flashing head lamps, ■ tail lamps, ■ and side-marker lights, ■ and a pulsing blowing of the horn will then alert anyone in the area when an illegal entry into your car is attempted.

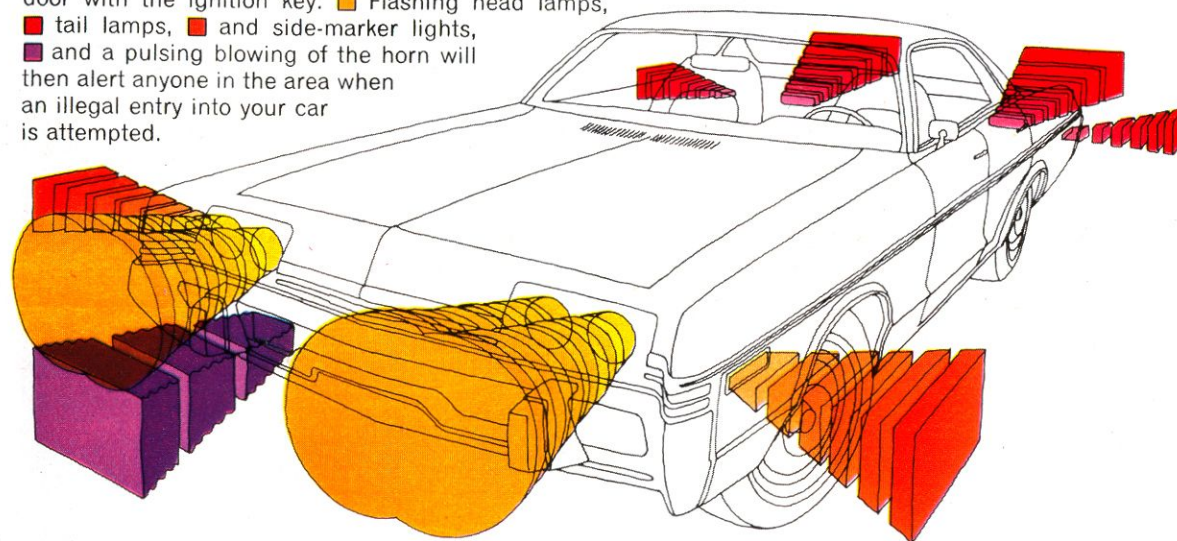

STANDARD EQUIPMENT

- Power steering • Power front disc brakes • Automatic transmission • Cloth-and-vinyl split-back front bench seat with fold-down center armrest • Extra-protection bumper system • Electric clock • Front and rear armrests • Simulated wood-grained door-trim insert with carpeted lower panel • Assist handles in door panels • 3-spoke color-keyed steering wheel with simulated wood-grained insert • Simulated wood-grained applique surrounding instrument cluster • Lower panel wood-grained applique • Inside hood release • Cigarette lighter • Combination dome and map light • Color-keyed carpeting • Instrument panel ash receiver light • Glove box light • Rear door automatic dome light switch • Head-lamp-on warning buzzer • Trunk light • Pedal-applied parking brake with hand-operated release • Keyless door-locking system • Heater/

- defroster with 3-speed fan • 2-speed concealed windshield wipers • Electric windshield washers • Concealed head lamps • Deluxe wheel covers

OPTIONAL EQUIPMENT

- 400 V8 2-bbl. or 440 V8 4-bbl. • Vinyl roof • Automatic speed control • Security Alarm System (requires power door locks) • Vent windows (4-door models only) • Air conditioning • Power windows • Power trunk lid release • Power seat • AM/FM multiplex stereo radio with or without cassette • Cornering lamps • Tilt steering wheel with "Rim Blow" horn • Rear window defogger • Light Package • Trunk carpet and carpeted spare tire cover • Sure Grip differential • Tinted glass • Power electric door locks • Premier wheel covers • Luxury Equipment Package

MONACO DIMENSIONS

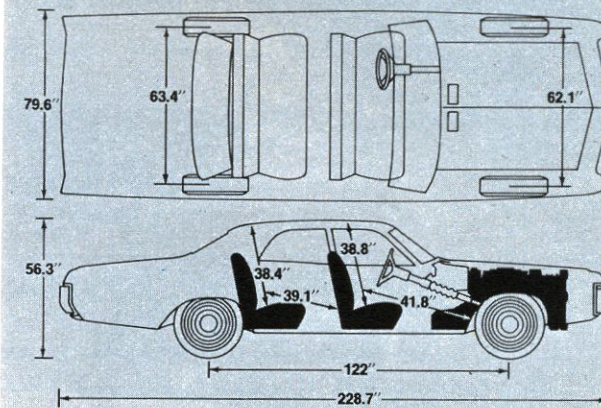

LUGGAGE CAPACITY

LADY'S PULLMAN	●
LADY'S WARDROBE	●
LADY'S OVERNIGHT BAGS	●●●●●
LADY'S TRAIN CASE	●
MAN'S TWO-SUITERS	●●●
MAN'S OVERNIGHT BAGS	●●●
BAG OF GOLF CLUBS	●

STANDARD SPECIFICATIONS

ENGINE:	360 V8
TRANSMISSION:	TorqueFlite 3-speed automatic
SUSPENSION:	Torsion-Quiet Ride, including torsion-bar front suspension and asymmetrical rear leaf springs
TIRES:	H78 x 15 BSW, bias-belted
WHEELS:	15 x 5.5
BRAKES:	Front: power disc; rear: 11" x 2" drum
ELECTRICAL SYSTEM:	Battery: 315-ampere (55-amp-hr) Alternator: 41-amp Electronic Ignition System Transistorized voltage regulator
FUEL TANK:	23 gallons
TRUNK CAPACITY:	22.4 cu. ft.

REAR AXLE AVAILABILITY

ENGINE	TRANSMISSION	STD.	OPT.
360 V8	TorqueFlite	2.71	3.23

Polara Custom. The big Dodge that's an easy step up to full-sized luxury.

The ultimate goal of most car buyers is owning a big, roomy luxury car. For 1973, Dodge Polara Custom is making that goal easier to attain. For all its good looks, large size, and roominess, the Polara Custom doesn't carry an exorbitant price tag. And what you get for your money is everything you've always imagined a luxury car would offer. Little things like a simulated wood-grained trim on the dash panel and doors, a vinyl-inserted protective body side moulding... big things like power steering, power front disc brakes and automatic transmission. If you've been waiting your turn to get into a full-sized luxury car, this could be the year. It's an easy step up when the car is a Dodge Polara Custom.



Polara Custom 4-Door Hardtop

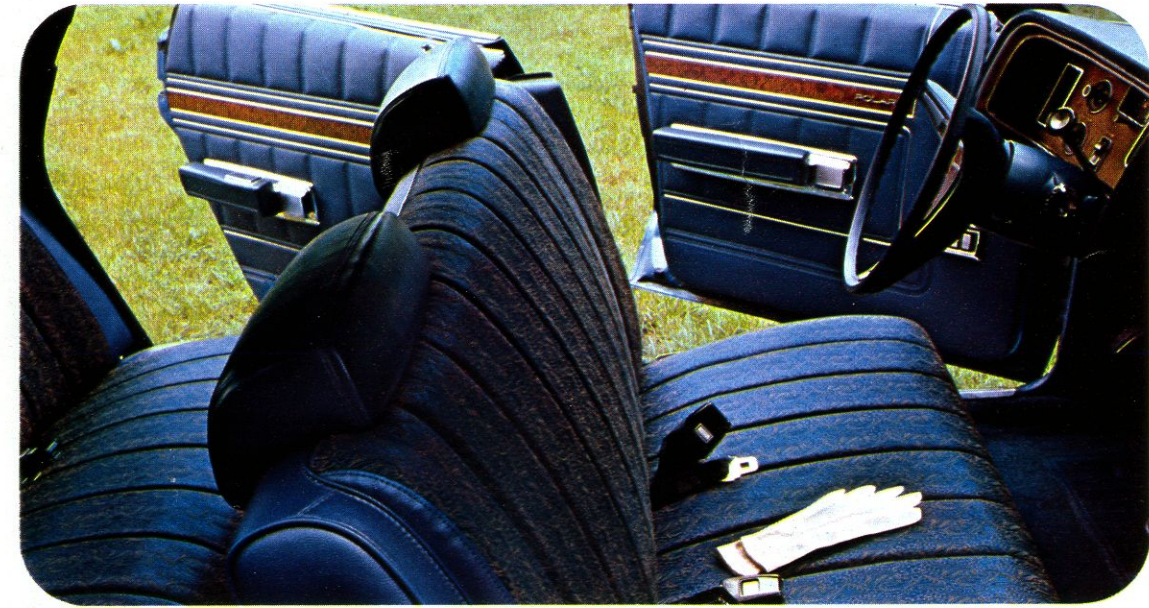

Polara Custom 4-Dr. Sedan.



Polara Custom 2-Dr. Hardtop.

Polara Custom's cloth-and-vinyl interior.

'73 Dodge Polara. The big Dodge that makes a lot of sense.

For a lot of people, a big car isn't a luxury, it's a necessity. They need a big, rugged, solidly built car like this Dodge Polara that has the interior roominess to handle a big family and its luggage with ease. Along with all this size and roominess, you get riding comfort and handling that are superb. Torsion-Quiet Ride isolates you from noise and road shock and lets you take the curves and corners with hardly a swerve or sway. And this year, the Electronic Ignition System is standard. This advanced feature eliminates breaker points and condenser, and, excluding the spark plugs, gives you a virtually maintenance-free ignition system. With all these quality and value features going for you, it makes a lot of sense to make Polara your big-car choice for '73.

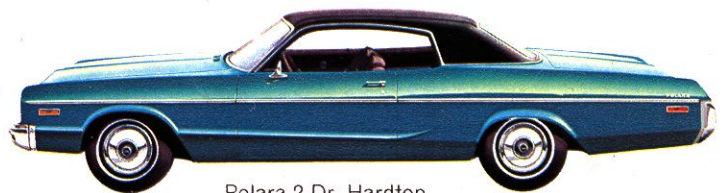

Polara 2-Dr. Hardtop.



Polara 4-Door Sedan



Polara's good-looking grille leads the way.

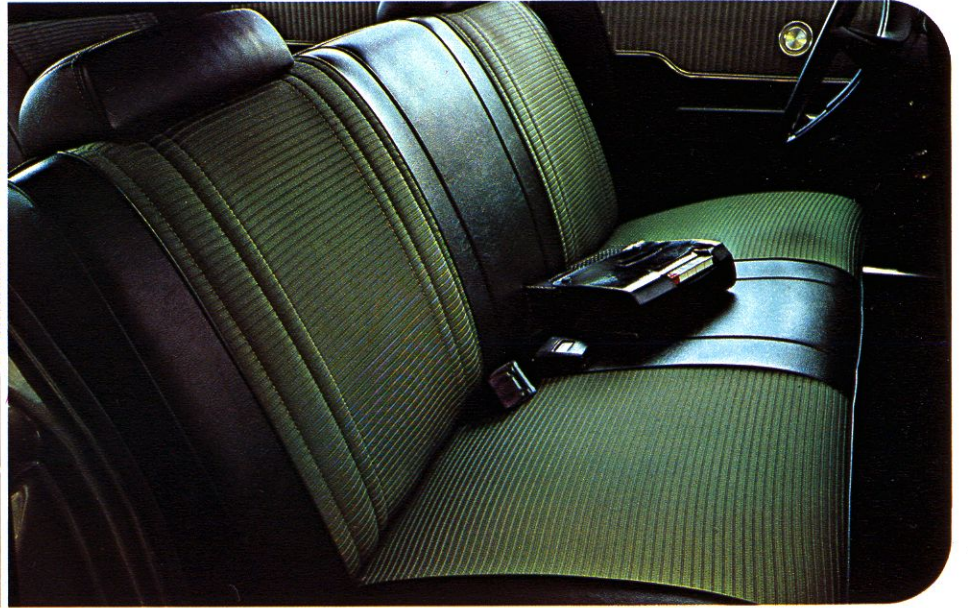

Polara's Peyton cloth-and-vinyl interior.

- A All-vinyl bucket seats are available on all Polara Custom two-door hardtops.
- B Optional front vent windows are available on all Polara/Monaco four-door models.
- C The Electronic Ignition System is standard on all Dodge V8 engines. With no points to wear out and no condenser to replace, this system reduces the frequency of resetting ignition timing under normal conditions.

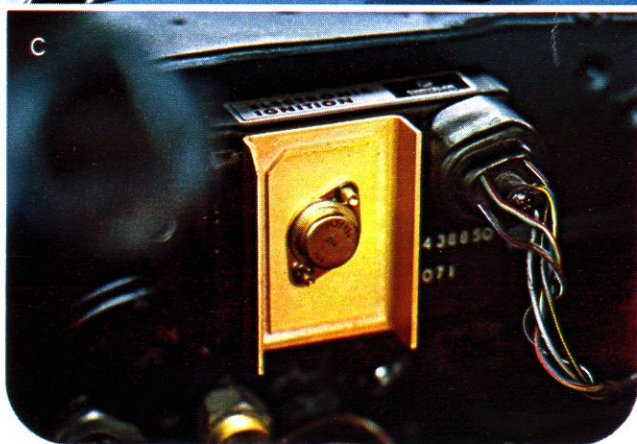

- D Front power disc brakes are standard on all Monaco and Polara models for 1973.
- E Power steering is standard on all Monaco and Polara models for 1973. Tilt, "Rim-Blow" steering wheel is optional.
- F TorqueFlite automatic transmission is standard on all Monaco and Polara models for 1973.

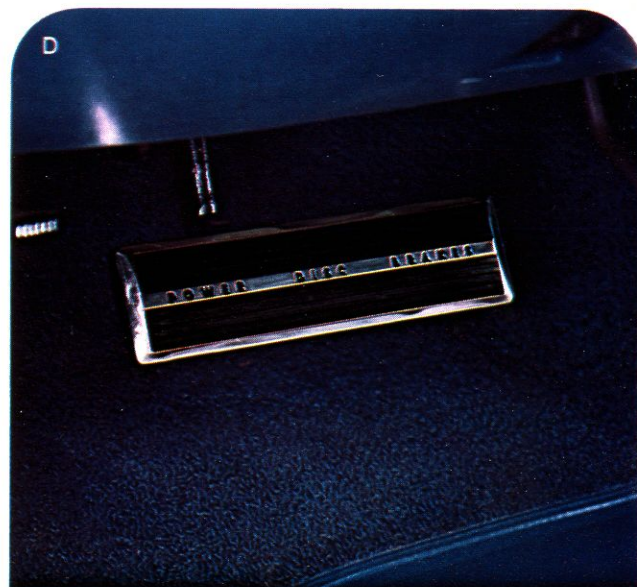

Some cars are built for chauffeurs, diamond cutters, and handwriting experts—Polara '73 is built for drivers like you.

TORSION-QUIET RIDE: Some of the things you don't see make a difference you can feel. ■ Independent torsion-bar springs have live springing action that helps smooth out your ride. ■ Torsion bars are also among the easiest types of suspensions to adjust. With a simple turn of a screw, your Polara can be adjusted to ride for years at the same height above the road as on the day you bought it. ■ Special rubber cushions are located at critical points to isolate the stub-frame from the car's body, and, more importantly, to isolate your body from road vibrations and noises. ■ Heavy rubber blocks located between the rear spring and the axle help isolate the passenger compartment from road bumps and vibrations.

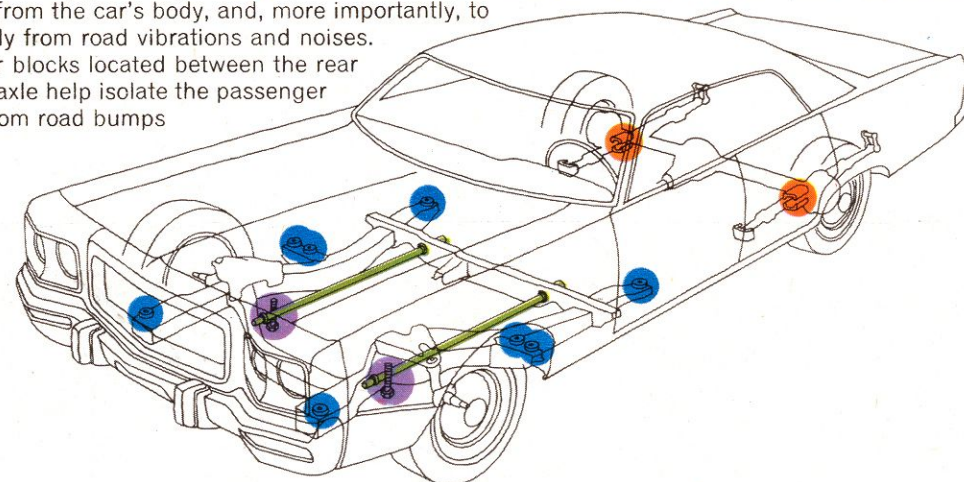

STANDARD EQUIPMENT

Cloth-and-vinyl front bench seat • Front and rear armrests • Extra-protection bumper system • Power steering • Power front disc brakes • Automatic transmission • Simulated wood-grained door-trim insert (Polara Custom) • 3-spoke color-keyed steering wheel with simulated wood-grained insert on Polara Custom • Glove box lock • Cigarette lighter • Inside hood release • Leather-grained black vinyl instrument cluster applique (Polara) • Simulated wood-grained applique surrounding instrument cluster (Polara Custom) • Lower panel wood-grained applique (Polara Custom) • Color-keyed carpeting • Keyless door-locking system • Day/night inside rearview mirror • 2-speed concealed windshield wipers • Electric windshield washers

OPTIONAL EQUIPMENT

360 V8 engine • 400 V8 2-bbl. or 440 V8 4-bbl. • Air conditioning • Vinyl roof • Security Alarm System (requires power door locks) • Manual vent front windows (4-door models only) • Automatic speed control • AM/FM multiplex stereo radio with or without cassette • Music Master AM radio • Rear seat speaker • Dual rear seat speakers (stereo only) • Power windows • Power seat • Power trunk lid release • Cornering lights • Electric clock • Sure Grip differential • Light Package • Rear window defogger • Tinted glass • Engine block heater • Protective rubber floor mats • Outside left remote-control mirror • 3-speed windshield wipers • Deluxe wheel covers • Premier wheel covers • Road wheels with chrome trim ring • Undercoating and hood pad • Luxury Equipment Package (Polara Custom)

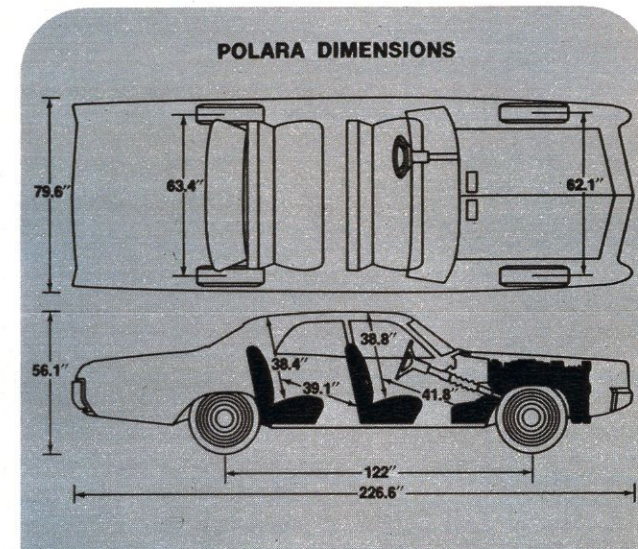

LUGGAGE CAPACITY	
LADY'S PULLMAN	●
LADY'S WARDROBE	●
LADY'S OVERNIGHT BAGS	●●●●●
LADY'S TRAIN CASE	●
MAN'S TWO-SUITERS	●●●
MAN'S OVERNIGHT BAGS	●●●
BAG OF GOLF CLUBS	●

STANDARD SPECIFICATIONS	
ENGINE:	318 V8
TRANSMISSION:	TorqueFlite 3-speed automatic
SUSPENSION:	Torsion-Quiet Ride, including torsion-bar front suspension, and asymmetrical rear leaf springs
TIRES:	G78 x 15 BSW, bias-belted
WHEELS:	15 x 5.0
BRAKES:	Front: Power disc; rear: 11" x 2" drum
ELECTRICAL SYSTEM:	Battery: 280-ampere (46-amp-hr) Alternator: 41-amp Electronic Ignition System Transistorized voltage regulator
FUEL TANK:	23 gallons
TRUNK CAPACITY:	22.4 cu. ft.

REAR AXLE AVAILABILITY			
ENGINE	TRANSMISSION	STD.	OPT.
318 V8	TorqueFlite	2.71	3.23



Charger SE

Charger SE. Rigged for silent running.

Welcome to the world of the elite. Meet Charger SE. This is a very personal luxury car for the man who knows what he wants... and why. Its lines are classic and clean. Its rakish upper quarter louvers are distinctive yet functional. Inside, silence and elegance abound. The silence comes from Charger's new Torsion-Quiet Ride and a system of special sound-deadening components. The luxury comes from such thoughtful touches as a Rallye Instrument Cluster, hideaway center armrest, embossed door panel trim, plush pile carpeting and simulated wood-grained inserts on panel and steering wheel. That's it. Charger SE for '73. Impressive? Impressive! Beyond your means? Don't bet on it.

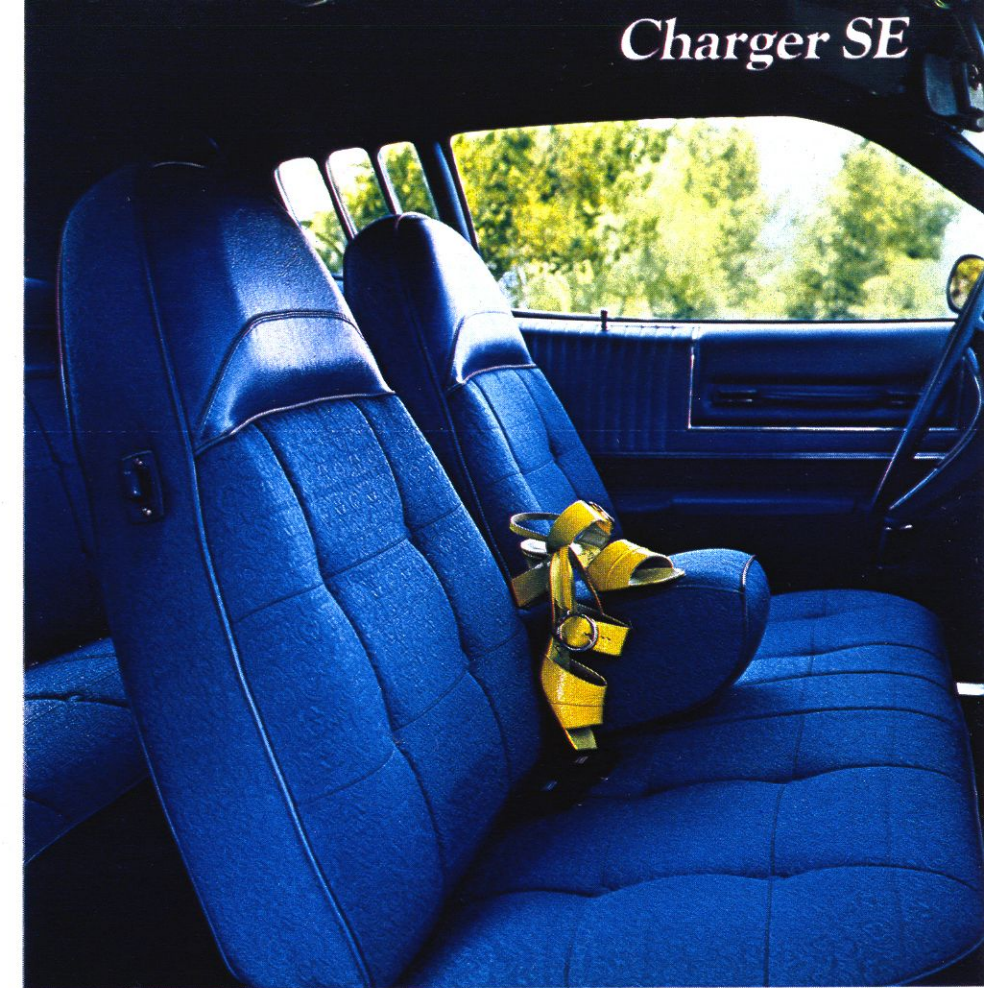

Optional Charger SE Brougham interior.
"The Great Shape"—Charger SE in profile.



Charger SE



Charger Hardtop

Charger. Remember when exciting cars used to be expensive? Forget it.

Where do you begin describing a car that's as outstanding as Charger? Most people start with the obvious: its looks. Charger's styling is in a class by itself, especially with its new choice of vinyl roof styles. Some prefer to talk about Charger's excellent handling characteristics. Charger is fun to drive. Thanks to a unique combination of torsion bars and new Torsion-Quiet suspension system, its ride is firm but not harsh. Front disc brakes are standard, too. And then there's Charger's price—or, rather, lack of it. Charger costs far less than you might imagine... yet its beauty, room, and ride leave nothing to the imagination. That's Charger for 1973—an exciting personal car with a price you can live with.



Charger Coupe.



Optional bucket seats and center console.
Optional "Halo" vinyl roof.



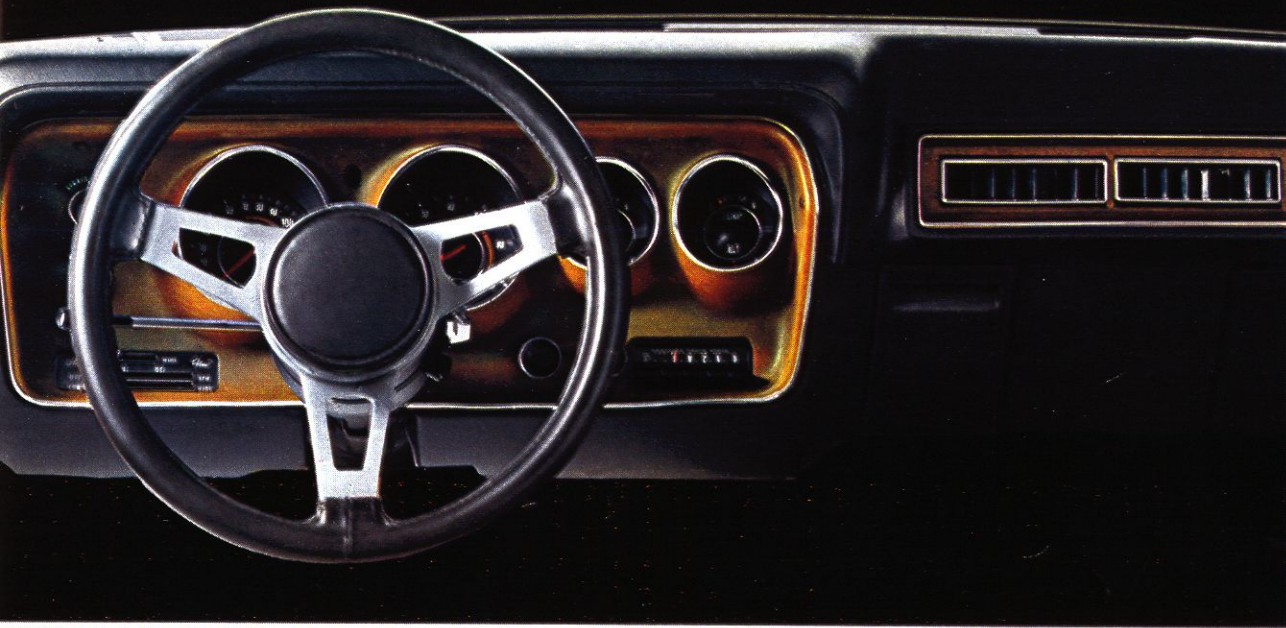

A Charger's Rallye Instrument Cluster is standard on SE and part of the optional Rallye Package. The rugged-looking "Tuff" steering wheel is available on all Charger models.

B Charger's sliding metal sun roof, available on all models equipped with a vinyl roof.

C Front disc brakes are standard on Charger. (And most Dodges for '73.)

D SE's hood ornament signals a return to the days when personal luxury cars ruled the road.

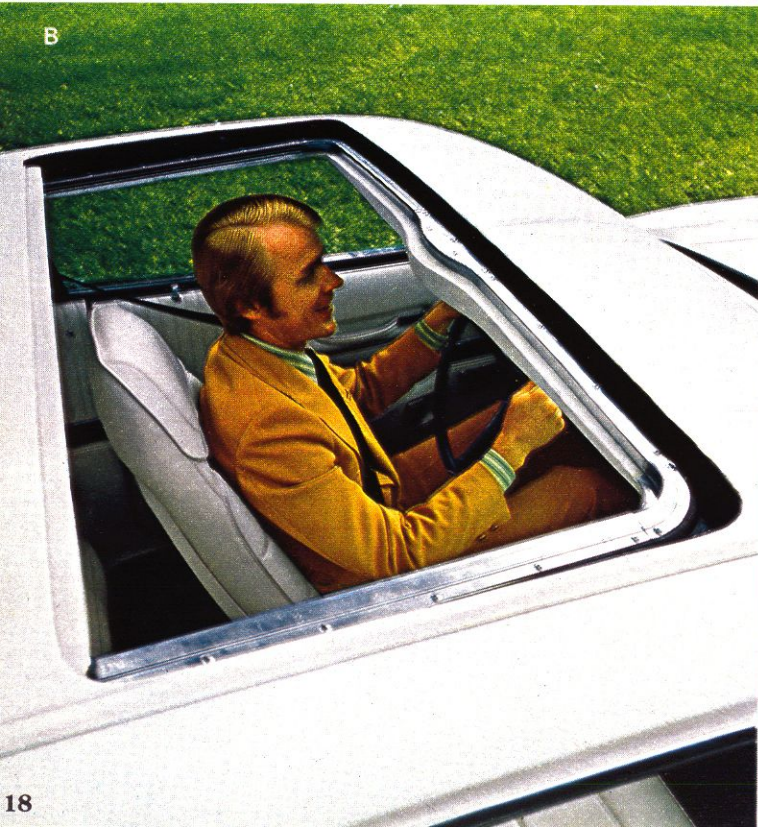

CHARGER RALLYE

The Rallye Package is available on V8 Charger hardtops and coupes, and includes the following items: Rallye Instrument Cluster • Power bulge hood • Body side tape stripe • Hood pins • Front and rear sway bars • F70 x 14 tires with raised white letters.



Rallye Hardtop.



Rallye Coupe.

Charger '73 has the last word about silence: Torsion-Quiet Ride!

TORSION-QUIET RIDE: Your 1973 Charger has an improved suspension system similar to the one we use on our full-sized Polaras and Monacos. It's called Torsion-Quiet Ride, and it consists of the following improvements over last year's Charger:

- An isolated front suspension crossmember, separated from the body by rubber mounts.
- Rubber iso-clamps around the rear leaf springs to reduce transmission of vibrations and rear axle noises.
- A double-coupling in the steering wheel to reduce road vibrations through the steering wheel.
- Extra sound-deadening materials and additional sealing to help reduce wind noises.

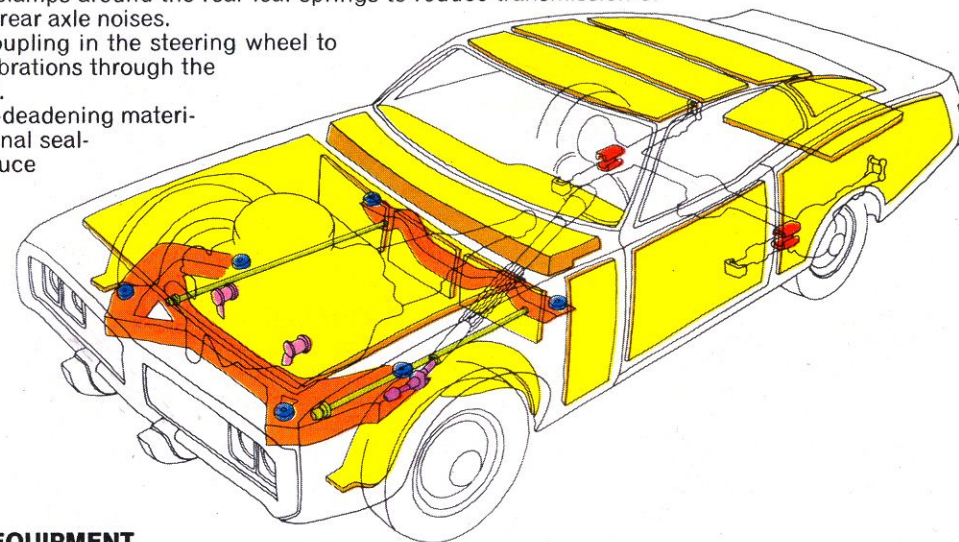

STANDARD EQUIPMENT

All-vinyl front bench seat (coupe and hardtop); cloth-and-vinyl trim available at no extra charge on the hardtop only • All-vinyl split-back front bench seat with center armrest (Charger SE) • Extra-protection bumper system • Glove box lock • Dome light with front door courtesy switch • Dual headlights • Color-keyed carpeting, dual horns, cigarette lighter, simulated wood-grained door trim inserts (except coupe) • Rallye Instrument Cluster, formal vinyl roof with fixed louvered quarter windows, and body side paint stripe (Charger SE) • Electric windshield washers • 2-speed concealed wipers

OPTIONAL EQUIPMENT

340 V8 4-bbl. (available on coupe and hardtop with Rallye Package only) • 400 V8 2-bbl. or 4-bbl. • 440

V8 4-bbl. (Rallye and SE) • Air conditioning (available with V8 engines only) • Manual sun roof (requires vinyl roof) • Electric clock • Instrument-panel-mounted hood release • Rear window defogger • Deluxe bumper guards • Power front disc brakes • Dual outside racing mirrors • AM/FM multiplex stereo radio with or without cassette • Light Package • Tachometer (available with Rallye Cluster and SE) • TorqueFlite automatic transmission • Bucket seats (except coupe) • Cloth-and-vinyl front seat with center armrest (Charger SE) • 4-speed manual, floor-mounted transmission with Hurst shifter, pistol grip handle, and reverse warning light • Floor console (with optional bucket seats only, no extra charge on Charger SE) • Power steering • Power windows (except coupe) • Canopy vinyl roof or "Halo" vinyl roof (NA Charger SE)

CHARGER DIMENSIONS

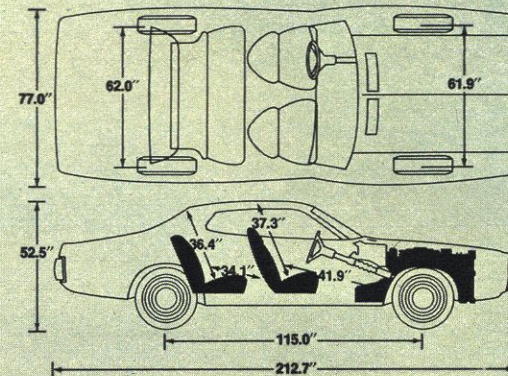

LUGGAGE CAPACITY

LADY'S PULLMAN	●
LADY'S WARDROBE	●
LADY'S OVERNIGHT BAGS	●●●
LADY'S TRAIN CASE	●
MAN'S TWO-SUITERS	●●
MAN'S OVERNIGHT BAG	●
BAG OF GOLF CLUBS	●

STANDARD SPECIFICATIONS

ENGINES:	225 Six (coupe and hardtop), 318 V8
TRANSMISSION:	3-speed manual, fully synchronized, column-mounted shift
SUSPENSION:	Torsion-Quiet Ride, including torsion-bar front suspension and asymmetrical rear leaf springs; front sway bar (SE)
TIRES:	E78 x 14 BSW, bias-belted F78 x 14 BSW (std. on all V8 models except Charger coupe)
WHEELS:	14 x 5.0, black enamel
BRAKES:	Front: Manual disc; rear: 10" x 2 1/2" drum
ELECTRICAL SYSTEM:	Battery: 280-ampere (46-amp-hr) Alternator: 41-amp Electronic Ignition System Transistorized voltage regulator
FUEL TANK:	19.5 gallons
TRUNK CAPACITY:	14.3 cu. ft.

REAR AXLE AVAILABILITY

ENGINE	TRANSMISSION	STD.	OPT.
225 Six	3-speed manual	3.21	3.23
	TorqueFlite	2.94	3.21
318 V8	3-speed manual	2.94	3.21
	TorqueFlite	2.71	3.21



Coronet Custom Sedan

Coronet '73. Lots of change for your family dollar, including the all-new Torsion-Quiet Ride.

Imagine, if you can, a car designed around your family. That's just what Dodge did before it built Coronet — a car designed to be a four-door sedan and nothing else. It's roomy, that's for sure... with a trunk of most generous proportions. Inside, handsome but durable upholsteries are the thing... accented with deep, all-nylon pile carpeting. And here's the frosting. This year, Coronet offers you and yours a new kind of gentle, silent ride. It's called the Torsion-Quiet Ride — for reasons that will become obvious after you've tried it. That's Coronet for 1973. Handsome, roomy, and smooth riding, with trim exterior dimensions that make parking and garaging a breeze. All in all, Coronet '73 is a great family car because Dodge planned it that way.



Coronet Sedan.



Coronet

Coronet Custom's Prelude cloth and Cologne vinyl interior... with ample family-sized rear seat.



Easy-to-read, full instrumentation.



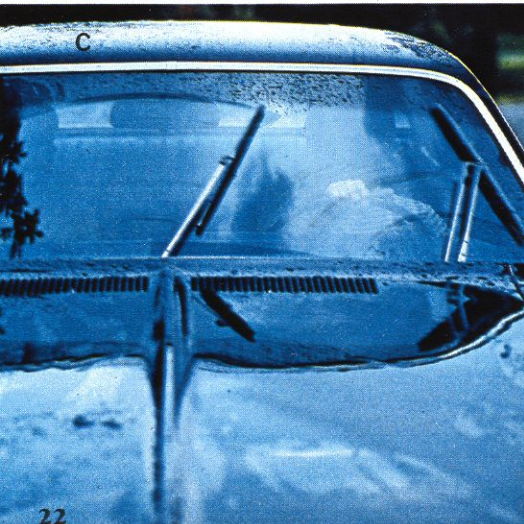

A Coronet's optional rear window defogger—a convenient, efficient solution to the problem of improved visibility under unfavorable weather conditions.

B Another example of Dodge's approach to better serviceability—head-lamp adjustment screws are now accessible without removing head-lamp or grille trim.

C All 1973 Dodges feature a new design wiper blade, proven in engineering tests to reduce smear and streaking tendencies. A minor improvement, perhaps, but one you'll really appreciate on rainy days.

D Coronet Custom's optional split-back bench seat and fold-down center armrest.

E A test-drive in the country is the best way to get a first-hand appreciation of Coronet's new Torsion-Quiet Ride. Take one today!

When Dodge says Coronet is family-sized, Dodge kids you not!

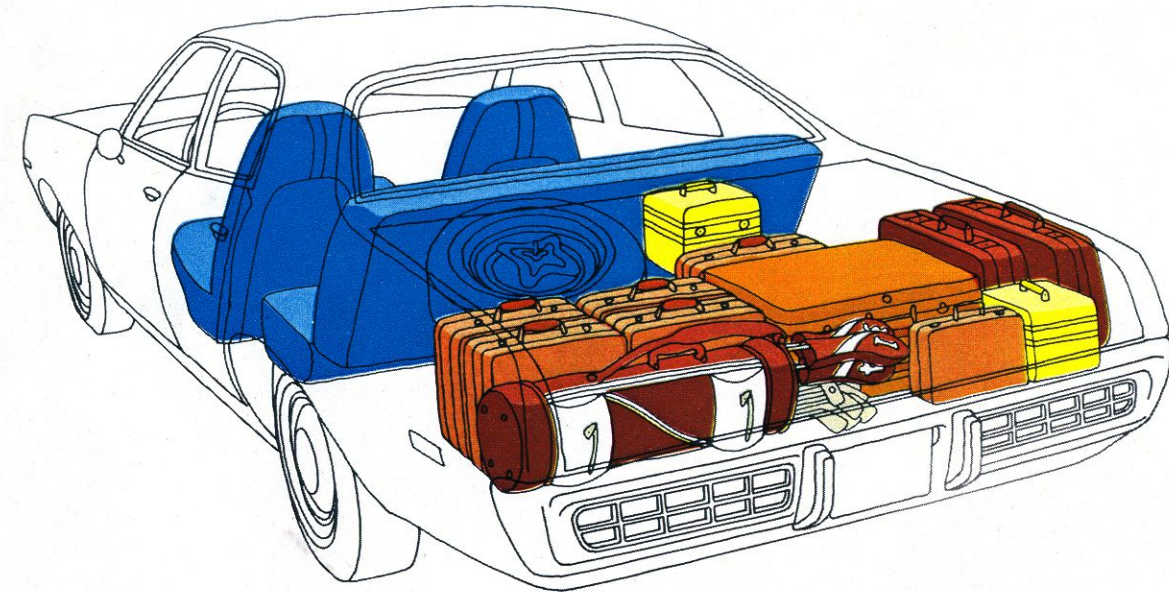

Compare Coronet's room to that of any car in its class, or that of *any* car for that matter, and you'll see why Coronet's called "family-sized." Check the handy chart at the right for dimensions and trunk capacity.

STANDARD EQUIPMENT

All-vinyl front bench seats (Coronet) • Pleated cloth-and-vinyl bench seats (Coronet Custom) • Extra-protection bumper system • Cigarette lighter • Front and rear ash receivers • Front and rear armrests • 2-speed concealed wipers • Seat spacers for seat height and angle adjustment • Dome light with front door courtesy switch • Glove box lock • Heater/defroster • Foot-operated parking brake • 3 spoke color-keyed steering wheel (with simulated wood-grained insert on Coronet Custom) • Dual horns, simulated wood-grained instrument panel applique and door trim inserts, color-keyed carpeting, and drip-rail, wheel-lip, and body side mouldings (Coronet Custom) • Cleaner Air System with Vapor Saver (gasoline evaporation control system)

OPTIONAL EQUIPMENT

400 V8 2- or 4-bbl. • Air conditioning (not available with 6-cylinder engines) • Automatic transmission • Power front disc brakes • Deluxe bumper guards • Vinyl roof • Deluxe wheel covers • Wire wheel covers • AM/FM radio • Instrument-panel-mounted hood release • Electric clock • Rear window defogger • 3-speed windshield wipers • Upper level fresh air ventilation • Undercoating and hood insulator pad • Light Package • AM/FM multiplex stereo with or without cassette • Music Master AM radio • Rear seat speaker (std. with stereo) • Sure Grip differential • Tinted glass • Outside left remote-control mirror • Power steering • Power windows • Vinyl body side protection moulding • Vinyl center armrest seat (Coronet Custom)

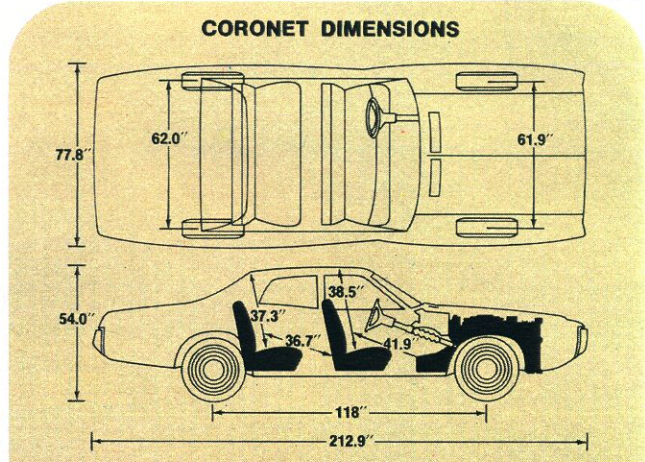

CORONET DIMENSIONS	
LADY'S PULLMAN	●
LADY'S WARDROBE	●
LADY'S OVERNIGHT BAGS	●●●●
LADY'S TRAIN CASES	●●
MAN'S TWO-SUITERS	●●
MAN'S OVERNIGHT BAG	●
BAG OF GOLF CLUBS	●

LUGGAGE CAPACITY	
ENGINES:	225 Six, 318 V8
TRANSMISSION:	3-speed manual, column-mounted shift
SUSPENSION:	Torsion-Quiet Ride, including torsion-bar front suspension and asymmetrical rear leaf springs; Oriflow shocks
TIRES:	E78 x 14 BSW, bias-belted F78 x 14 BSW (std. on all V8 models)
WHEELS:	14 x 5.0, black enamel
BRAKES:	Front: Manual disc; rear: 10" x 2 1/2" drum
ELECTRICAL SYSTEM:	Battery: 280-ampere (46-amp-hr) Alternator: 41-amp Electronic Ignition System Transistorized voltage regulator
FUEL TANK:	19.5 gallons
TRUNK CAPACITY:	16.7 cu. ft.

STANDARD SPECIFICATIONS			
REAR AXLE AVAILABILITY			
ENGINE	TRANSMISSION	STD.	OPT.
225 Six	3-speed manual	3.21	3.23
	TorqueFlite	2.94	3.21
318 V8	3-speed manual	2.94	3.21
	TorqueFlite	2.71	3.21



Here's a sporty car that's everything its name implies: Challenger!

The sports car. It's a personal thing. And getting personal about the 1973 Challenger: There's something in the way it moves. A well-balanced machine. Moving promptly with a 318 cu.-in. V8 (or you may choose the optional 340 four-barrel V8). Halting with front disc brakes. Tracking firmly with front and rear sway bars (optional). Or getting more personal—the Challenger Rallye Package appearing very noticeably to the left. Our Rallye includes performance hood, fender scoops with gradated stripes, Rallye Instrument Cluster, Rallye Suspension with front and rear sway bars with 340 V8 engine, and more. Challenger—quite a name among sports cars.

STANDARD EQUIPMENT

All-vinyl bucket seats with integral head restraints • Extra-protection bumper system • Deep-cut pile carpeting • Simulated wood-grained door trim inserts • Front and rear ash receivers • Heater/defroster • Keyless door-locking system • Front and rear armrests • Ventless front windows • Concealed 2-speed windshield wipers and washers • Dual body paint stripes • Wheel opening, roof-drip-rail, grille surround, and deck lid mouldings • Dome light • Cigarette lighter • Glove box lock • Day/night inside mirror

OPTIONAL EQUIPMENT

340 V8 engine • Air conditioning • Vinyl roof • TorqueFlite 3-speed automatic transmission • Power front disc brakes • Light Package • Rear window defogger • Dual racing mirrors (bright or painted) • Instrument-panel-mounted hood release • 3-speed windshield wipers with electric washers • Rallye Suspension (std. with Rallye Package and 340 V8 engines) • Music Master radio • Electric clock • Rallye Instrument Cluster (std. with Rallye Package) • Deluxe wheel covers • Rallye road wheels with chrome trim ring • AM/FM multiplex stereo radio • Power steering • AM radio with stereo cassette



Challenger's Empire vinyl bucket seats.

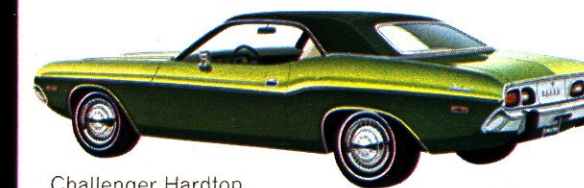

Challenger Hardtop.

CHALLENGER DIMENSIONS

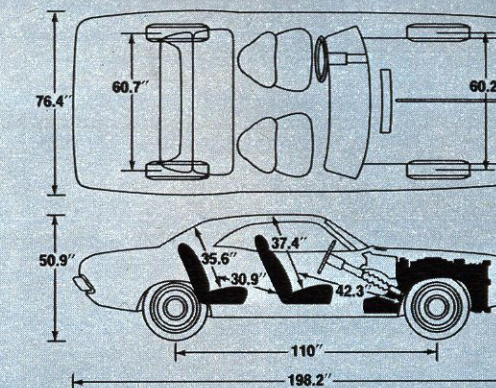

LUGGAGE CAPACITY

LADY'S TRAIN CASES	●●●●
LADY'S OVERNIGHT BAGS	●●●●●
MAN'S OVERNIGHT BAG	●
BAG OF GOLF CLUBS	●

STANDARD SPECIFICATIONS

ENGINE:	318 V8
TRANSMISSION:	3-on-the-floor, fully synchronized manual
SUSPENSION:	Front: Torsion bars Rear: Asymmetrical leaf springs Heavy-duty Rallye Suspension with front and rear sway bars (Rallye)
TIRES:	7.35 x 14 polyester BSW (Challenger) F70 x 14 bias-belted WSW (Rallye)
WHEELS:	14 x 5; 14 x 5.5 (with F70 x 14 tires)
BRAKES:	Front: Manual disc Rear: 10" x 2 1/2" drum
ELECTRICAL SYSTEM:	Battery: 280-ampere (46-amp-hr) Alternator: 41-amp Electronic Ignition System Transistorized voltage regulator
FUEL TANK:	18 gallons
TRUNK CAPACITY:	8.6 cu. ft.

REAR AXLE AVAILABILITY

ENGINE	TRANSMISSION	STD.	OPT.
318 V8	3-speed manual	3.23	—
	TorqueFlite	2.76	3.23



Dart Custom Sedan & Swinger Hardtop

Dart Custom cloth-and-vinyl interior.



Swinger interior, including optional fold-down center armrest seat.

More than one million economy lovers have bought Dart already. How about you?

We modestly admit Dart is one of the most appealing compacts ever built. Our hit with economy seekers also happens to be big enough for the comfort of six passengers. Our compact, which can easily survive in city traffic and swing into tight parking spaces, holds its own on the highways with a stable 111-inch wheelbase and the firm control of torsion-bar suspension. And if you need one word to describe Dart, try "value." It's a lot of car for the price, with a traditionally high resale value. We also have an idea that a car should last. For instance, we use Unibody construction—the body and frame are built as one unit for a strong, tight structure. While for 1973 Dart remains basically the same compact many people know and love, we have added a few new appeals. For instance, the revolutionary Electronic Ignition System is standard. And you can order more skylight with the optional sliding metal sun roof available on two-door models. Whichever Dart you choose, you're traveling with a lot of company.



Dart Sedan.



Dart Swinger Special.

Dodge invents the Convertriple. Three cars for the price of one. Dart Sport.



Dart 340 Sport



Dart Sport's Optional Utility Package gives you six and one half feet of carpeted cargo area with the security panel and rear seat folded down . . .



. . . or, a locked trunk of generous proportions with the security panel raised to its upright position. Security panel latch can be opened from trunk side only.



And thanks to the fold-down feature of Dart Sport's front seat, you've got even more room on the passenger side for those extra-long items. How many other five-passenger cars can you name with this useful feature?

CAR ONE: the 1973 Dart Sport. Quite a car just the way it is—a five-passenger economy coupe with a lot more going for it than the minis. Important extras like greater weight and longer wheelbase for more highway stability. And more trunk space . . . much more. Now, add the optional sliding metal sun roof, and you've got CAR TWO: a refreshing way to raise your spirits for a low price. Order the Sport with the optional fold-down rear seat, and you have CAR THREE: an honest worker with a cargo area six and one half feet long. (As shown at the left, a security panel is used to prevent access to the trunk from the interior of the car.)

Now that we have run through cars 1, 2, and 3, there is one Sport to go: the Dart 340 Sport. The 340 four-barrel V8 is standard, along with Rallye

Suspension, dual exhausts, and other high-spirited items. Sport or 340 Sport, Dart gives you two exciting new ways to go.



Dart Sport.

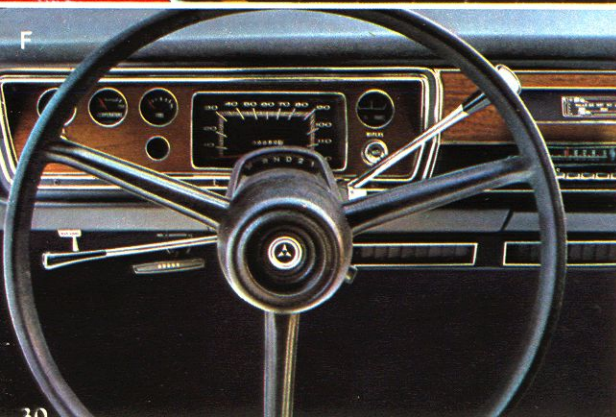
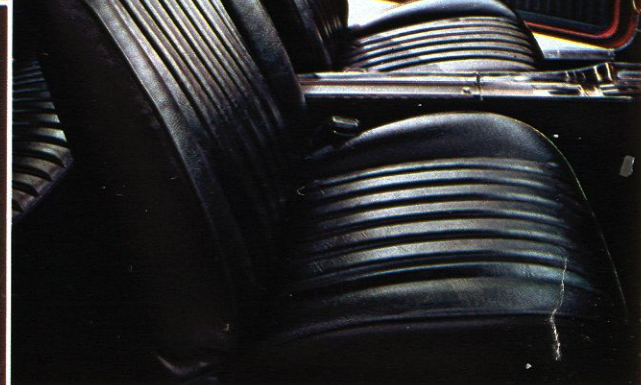
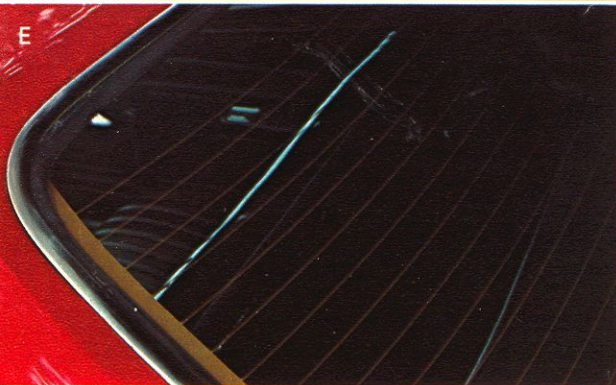
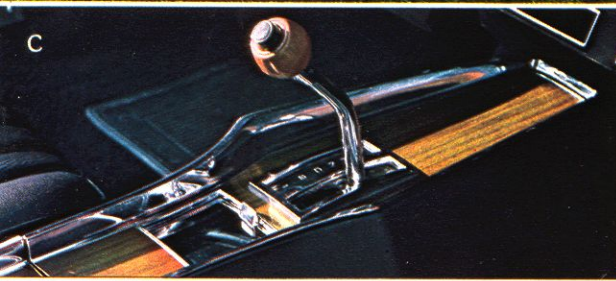

A Unless you're currently a Dart owner, you may find it hard to believe that all that luggage fits into Dart's trunk.

B Dart's hidden spare tire is one of the reasons it does.

C This good-looking center console is available on all Dart Sports equipped with bucket seats and an automatic transmission.

D These buckets are one of the three optional seats you can order on your new Dart Sport.

E Dart Sport's optional rear-window defroster uses electrically heated filaments embedded in the glass to make a clean sweep of icy windows.

F Dart's instrument panel features gauges and warning lights to let you know what's going on under the hood.

G Dart's standard bumper and optional bright-base bumper guards—a good-looking approach to exterior styling.

OPTIONAL EQUIPMENT

225 6-cylinder engine • Air conditioning (except with 198, 6-cylinder engine) • Tinted glass • 3-speed manual transmission, floor-mounted (Dart Sport and Dart 340 Sport) • 4-speed manual transmission, floor-mounted, with Hurst shifter (Dart 340 Sport) • TorqueFlite automatic transmission, column-mounted, or floor console (Dart Sport models) • Front bucket seats (Dart Sport models) • Manual sun roof (coupe and hardtop) • Power front disc brakes (std. on Dart 340 Sport) • Outside left remote-control mirror • AM or AM/FM radio • Rear window defogger • Rear-seat speaker • Fold-down rear seat with security panel and trunk dress-up (Dart Sport models) • Light Package • Electric rear window defroster (Dart Sport models)

You want an economy car that's roomy, strong, and durable. Dodge understands.

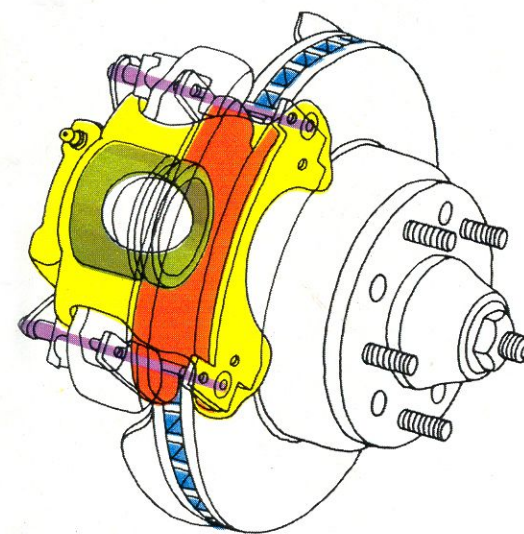

IMPROVED DISC BRAKES: Surer stopping power, less costly maintenance.

- Dodge's improved disc brake system features a floating caliper that minimizes brake deflection under hydraulic pressure.
- Fixed pins maintain the radial alignment between the caliper and the disc pads.
- Use of a single piston reduces maintenance costs over those of the previously used four-piston type of disc brake.
- The disc brake pads can be easily checked by looking through the caliper access hole.
- Ventilated discs with a large heat transfer area help reduce braking temperatures.

STANDARD EQUIPMENT

All-vinyl front bench seat (Swinger and Dart) • Cloth-and-vinyl front bench seat (Dart Sport, Dart 340 Sport, Swinger Special, and Dart Custom) • Extra-protection bumper system • Simulated wood-grained cluster applique on instrument panel • 2-speed electric windshield wipers • Front armrests • Cigarette lighter (except Dart Sport) • Keyless door-locking system • Deep-pile carpeting (except on Dart and Swinger Special) • Dual horns, and rear armrests (Dart Custom and Swinger) • Front window vents (Dart and Dart Custom) • Body side and rear deck lid performance tape stripes (Dart 340 Sport) • Body side mouldings with painted insert (Dart Custom and Swinger) • Wheel-lip mouldings (Dart Sport models) • Grille surround and hood front edge mouldings • Roof drip-rail moulding (except on Dart and Swinger Special) • Heater/defroster

STANDARD SPECIFICATIONS

ENGINES:	198 Six (NA in Calif.) 318 V8 340 4-bbl. V8 (Dart 340 Sport)
TRANSMISSION:	3-speed manual, column-mounted; or floor-mounted (Dart 340 Sport)
SUSPENSION:	Front: Torsion bars (front sway bar—Dart 340 Sport) Rear: Asymmetrical leaf springs
TIRES:	6.95 x 14 BSW E70 x 14 BSW (Dart 340 Sport)
WHEELS:	14 x 4.5 14 x 5.5 (Dart 340 Sport)
BRAKES:	Front: Disc (V8); 9" x 2 1/2" drum (6-cyl.) Power disc (Dart 340 Sport) Rear: 10" x 2 1/2" drum (V8); 9" x 2" drum (6-cyl.)
ELECTRICAL SYSTEM:	Battery: 280-ampere (46-amp-hr) Alternator: 34-amp (6-cyl. models) 41-amp (V8 models) Electronic Ignition System Transistorized voltage regulator
FUEL TANK:	16 gallons
TRUNK CAPACITY:	15.9 cu. ft. (Dart Sport) 14.3 cu. ft. (Dart)

REAR AXLE AVAILABILITY

ENGINE	TRANSMISSION	STD.	OPT.
198 Six	3-speed manual	3.23	—
	TorqueFlite	2.76	3.21
318 V8	3-speed manual	3.21	—
	TorqueFlite	2.76	3.21
340 V8	3- or 4-speed manual	3.21	3.55
	TorqueFlite	3.21	3.55

DART SPORT DIMENSIONS

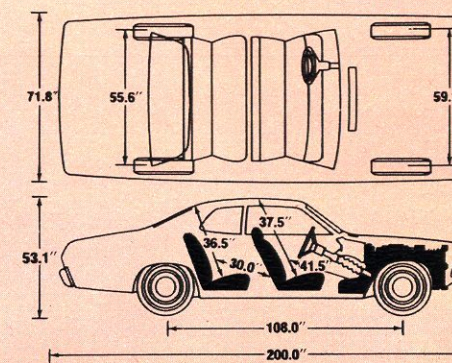

LUGGAGE CAPACITY

LADY'S PULLMAN	●
LADY'S WARDROBE	●
LADY'S OVERNIGHT CASES	●●
LADY'S TRAIN CASES	●●●
MAN'S TWO-SUITERS	●●
MAN'S OVERNIGHT CASES	●●
BAG OF GOLF CLUBS	●

DART DIMENSIONS

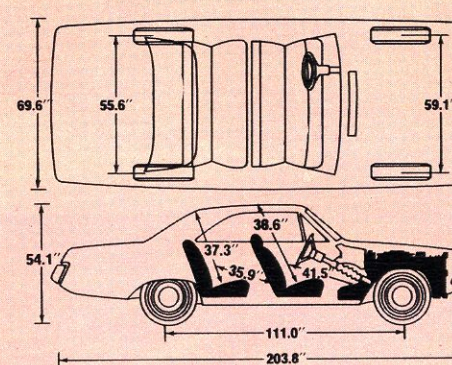

LUGGAGE CAPACITY

LADY'S PULLMAN	●
LADY'S WARDROBE	●
LADY'S OVERNIGHT CASES	●●
LADY'S TRAIN CASE	●
MAN'S TWO-SUITER	●
MAN'S OVERNIGHT CASES	●●
BAG OF GOLF CLUBS	●



Polara Custom Wagon

Monaco Wagon

We've got the wagons covered.

Dodge offers six new models this year. Starting at the top: the Monaco, the Polara Custom in two- and three-seat models, and the Polara in a two-seat model. Two Coronet wagons are described on the following pages.

The full-sized Polara/Monaco wagons you see here are generously proportioned by any standard. While they differ in style and trim appointment, they share a common heritage: Dodge practicality and dependability. Electronic Ignition is standard, of course, as is Dodge's advanced Torsion-Quiet Ride suspension. This system helps make these wagons as much at home on Cumberland trails as on Interstate 75. All models feature front disc brakes, a two-way tailgate and an aerodynamic wind deflector that helps keep the rear window clean. Remember, too, that the two-seat-wagon models have a concealed storage compartment under the floor. Sensible options include manually operated vent panes, dual air conditioning, aluminum/steel roof rack, and steel-belted, radial ply tires.



Polara/Monaco's standard air deflector.

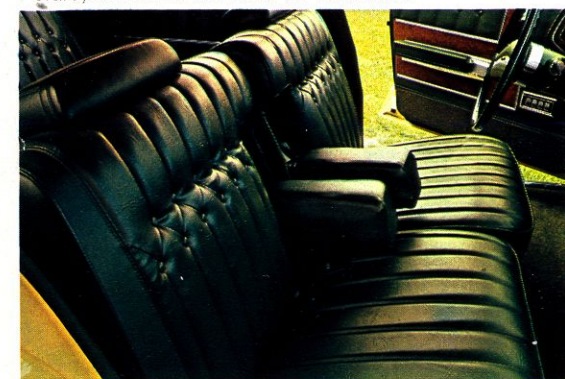

Monaco's optional "50/50" seat.



Polara Wagon.

Polara & Monaco Wagons

POLARA/MONACO WAGON DIMENSIONS

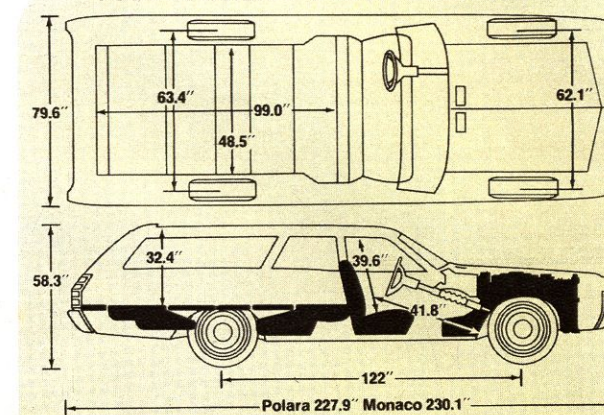

STANDARD SPECIFICATIONS

ENGINE:	360 V8
TRANSMISSION:	TorqueFlite 3-speed automatic
SUSPENSION:	Torsion-Quiet Ride; torsion bars in front Asymmetrical leaf springs in the rear
TIRES:	J78 x 15 BSW (2-seat wagons) L84 x 15 BSW (3-seat wagons)
WHEELS:	15 x 6.5
BRAKES:	Front: Power disc; rear: 11" x 2 1/2" drum
AXLE RATIOS:	2.76:1 (Opt. Sure Grip 2.76, 3.23)
ELECTRICAL SYSTEM:	Battery: Polara: 280-ampere (46-amp-hr) Monaco: 315-ampere (55-amp-hr)
	Alternator: 41-amp
	Electronic Ignition System High-speed starter Transistorized voltage regulator
FUEL TANK:	23 gallons
CARGO VOLUME:	104.2 cu. ft.

STANDARD EQUIPMENT

All-vinyl front bench seat (Polara and Polara Custom) • All-vinyl, split-back front bench seat with center armrest (Monaco) • Power steering • Power front disc brakes • Automatic transmission • Color-keyed carpeting • 2-speed concealed wipers and washers • Aerodynamic roof air deflector • Instrument-panel-mounted hood release • Keyless door-locking system • Extra-protection bumper system • Cargo compartment side storage panels • Hardtop-type tailgate • 3-spoke color-keyed steering wheel with simulated wood-grained insert, simulated wood-grained door-trim inserts, and cargo compartment lock and carpeting (Polara Custom and Monaco) • Concealed headlights, deluxe wheel covers, and exterior simulated wood-grained overlay (Monaco) • Heater/defroster • Auto-Lock electric tailgate lock system (3-seat wagons)

Lots more than just a lot of room. Coronet '73.

Don't let Coronet's trim outside dimensions fool you. You're sure to be surprised when you see firsthand how roomy it is. A 4-x-8-foot sheet of plywood will prove its carrying capacity. But rest assured that this wagon was built for people. Mothers across the country applaud Coronet's easy handling and kiddie-proof upholsteries. Its new Torsion-Quiet

Ride is so smooth that the first thing you'll notice about it is that you'll probably never notice it. And all you value-lovers will do well to take a minute and run your finger down that list of equipment on the right. So, get set for the smoothest, roomiest, quietest Coronet yet. At a price that whispers, "You can afford it... you can afford it."

CORONET WAGON DIMENSIONS

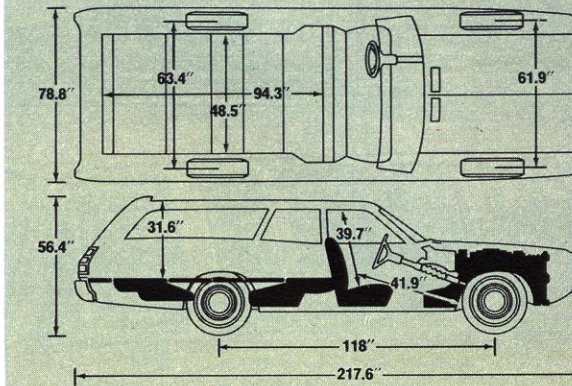

STANDARD SPECIFICATIONS

ENGINE:	318 V8
TRANSMISSION:	3-speed manual, column-mounted shift
SUSPENSION:	Front: Torsion bars with sway bar Rear: Asymmetrical leaf springs
TIRES & WHEELS:	H78 x 14 BSW tires; 14 x 5.5 wheels
BRAKES:	Front: Power disc; rear: 11" x 2 1/2" drum
ELECTRICAL SYSTEM:	Battery: 280-ampere (46-amp-hr) Alternator: 41 amp Electronic Ignition System Transistorized voltage regulator
FUEL TANK:	21 gallons
CARGO VOLUME:	91.3 cu. ft.

STANDARD EQUIPMENT

All-vinyl front bench seat (Coronet/Coronet Custom) • All-vinyl split-back front bench seat with center armrest (Coronet Crestwood) • Extra-protection bumper system • 2-speed concealed wipers • Electric windshield washers • Power front disc brakes • Dome light with front door courtesy switch • Keyless door-locking system • Dual Action tailgate with concealed hinges • Glove box lock • Heater/defroster with 3-speed blower fan • 3-spoke color-keyed steering wheel (Coronet) • Color-keyed carpeting (except Coronet) • 3-spoke color-keyed steering wheel with simulated wood-grained insert, and dual horns (Coronet Custom and Coronet Crestwood) • Cargo compartment carpeting and dome light, aerodynamic roof air deflector, and exterior simulated wood-grained overlay (Coronet Crestwood)



Coronet Crestwood Wagon

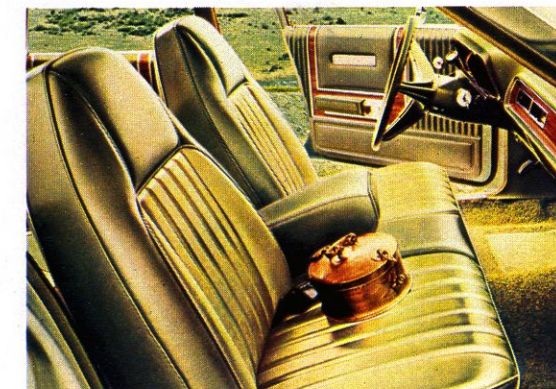

Crestwood's standard interior includes a fold-down center armrest.



A 4' x 8' piece of paneling lies flat in all Coronet models, even with the tailgate closed.



Coronet.



Coronet Custom.



Sportsman. Big as all outdoors.

Our Sportsman wagon covers a lot of territory—from a wanderlust adventure far from any highway to an ordinary drive down an everyday street. Sportsman covers it all. You have a rugged, independent front suspension, a trip-sized 25-gallon fuel tank (bigger than any other wagon's), and other Dodge dependability

features going for you.

And a woman may have her own ideas about Sportsman's territory—shopping centers or city streets. If it's her turn for the kiddie school pool, the Dodge Maxiwagon model holds fifteen people (more than any other wagon can handle). Other Sportsman seating capacities accom-

modate five, eight, or twelve passengers.

The Sportsman also covers a lot of territory in choices—models, wheelbases, options, and more. The next move is yours. See your Dodge Dealer for complete information and ask for a copy of the 1973 Dodge Sportsman wagon catalog. Do it soon.

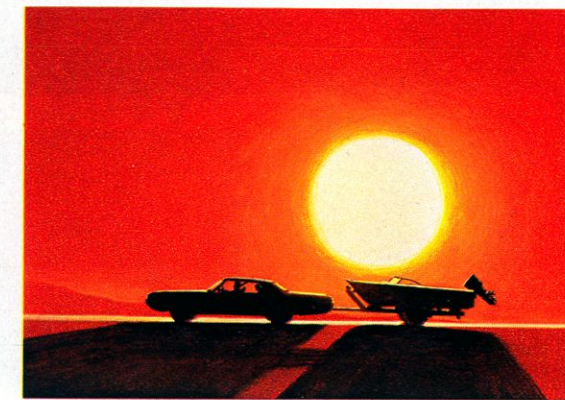

THE DODGE TRAILER-TOWING PACKAGE. HERE'S WHAT YOU'LL GET, AND WHY YOU'LL NEED IT.

This year, Dodge offers one of the most complete trailer-towing packages in the industry. Dart and Dart Sport can safely pull trailers weighing up to 2500 pounds; Charger and Coronet can handle trailers weighing up to 6000 pounds; and Polara/Monaco can handle trailers weighing up to 7000 pounds.

TRAILER WIRING HARNESS—Built right into your car's normal wiring system, this seven-wire harness gives you a current source to your trailer without a costly, time-consuming alteration of the electrical system.

HEAVY-DUTY SUSPENSION—Stronger rear springs, torsion bars and front sway bar help support and smooth out the extra load transmitted to your car's suspension when you're towing a trailer.

HIGH-CAPACITY RADIATOR—A heavy-duty radiator is an absolute must for dissipating the extra heat your engine develops when pulling a trailer.

FAN SHROUD—A fan shroud is a highly efficient method of directing all the air your fan circulates directly to the radiator to aid in cooling the engine.

COOLANT RESERVE SYSTEM—Located behind the radiator, this system collects and condenses cooling system vapors and feeds them back into the cooling system.

VARIABLE-LOAD TURN SIGNAL FLASHER—This flasher handles the extra electrical current load required to operate your trailer's turn signal indicators.

60-AMP HEAVY-DUTY CHRYSLER ALTERNATOR—While Dodge's standard batteries are sufficient for trailer-towing, a heavy-duty alternator is provided to generate enough electrical current to handle the additional requirements of trailer-towing.

HEAVY-DUTY REAR AXLE—A heavy-duty, 3.23:1 rear axle ratio increases your car's trailer-pulling power and cuts down on engine loading.

EXTRA-WIDE WHEEL RIMS—Wider wheel rims help reduce side sway and accommodate the larger tire sizes required with trailer-towing packages. (See section on required additional equipment.)

AUXILIARY TRANSMISSION OIL COOLER—This Dodge feature eliminates transmission overheating and the extra load put on your transmission by trailer-towing. It's included in the packages available on Charger/Coronet and Polara/Monaco models.

Trailer Towing

ADDITIONAL REQUIRED EQUIPMENT: To ensure safe, efficient trailer-towing operation, an automatic transmission, power front disc brakes, and larger tire sizes are required equipment with all Dodge trailer-towing packages. These options are not included in the trailer-towing package due to the fact that the automatic transmission and power front disc brakes are standard on all Polaras and Monacos, and power front disc brakes and larger tire sizes are standard on all Coronet wagons. (Consult your Dealer for the tire sizes required on other Dodge models.)

OTHER PACKAGES

The following packages are available for those drivers who intend to pull only light-weight trailers or who don't intend to pull trailers but do intend to do a lot of long-distance driving:

HEAVY-DUTY PACKAGE, including a heavy-duty suspension system, extra-wide wheel rims, and a maximum cooling system consisting of a high-capacity radiator, a fan shroud, and a coolant reserve system.

TRAILER WIRING PACKAGE, including a trailer wiring harness, a 60-amp alternator, and a variable-load turn signal flasher.

SPORTSMAN TRAILER-TOWING. In addition to the car packages listed on this page, Dodge also offers a trailer-towing package on all Sportsman models. Let your Dodge Dealer know what type of trailer you intend to pull with your Sportsman, and he'll design the right package to fit your needs.

Many Dealers are also equipped to install a trailer tow bar on your new Dodge. Ask your local Dodge Dealer for complete details.

Safety Features

Cleaner Air System with Vapor Saver (gasoline evaporation control system)
• Antitheft steering column lock
• Backup lights • Breakaway front ash-tray • Combination side markers, light reflectors • Dual Braking System • Extra-protection bumpers • Energy-

absorbing steering column and wheel
• 3-point safety belt system with locking retractors • Hazard warning system • Head restraints • "Key-left-in-ignition" warning buzzer • Manual latches on folding front seatbacks
• Left outside mirror • Inside rearview

mirror with double-ball-joint safety mount • Nonoverride door locks, except on driver's door • Padded instrument panel and sun visors • Parking brake • Parking brake and master

cylinder warning light • Safety-Action inside door handles • Safety-Rim wheels • Soft knobs on window cranks
• Turn signals with lane-change features • Windshield wipers and washers

Options - you want options? You've come to the right place.

Air conditioning

Dual air conditioning (Polara/Monaco wagons)
Automatic speed control (Polara/Monaco)

Power front disc brakes (Dart, Challenger, Charger, & Coronet)

Carpeting (Dart, Dart Swinger Special, Charger coupe, & Coronet)

Electric clock (Challenger, Charger, Coronet, Polara, & Polara Custom)

Console (available with bucket seats & automatic transmission, on Dart Sport, Challenger, & Charger)

Security Alarm System (Polara/Monaco)

Engines: 225 6-cylinder • 340 4-bbl. V8 • 360 2-bbl. V8 • 400 2-bbl. V8 Magnum • 400 4-bbl. V8 Magnum • 440 4-bbl. V8 Magnum.

Consult your Dodge salesman for complete engine availability.

Performance hood & hood scoop (Dart Sport, Challenger & Charger Rallyes)

Inside hood release (std. Polara/Monaco)

Rallye Instrument Cluster (with Rallye Packages on Challenger & Charger)

Dual racing mirrors, painted or chrome (Dart Sport, Challenger & Charger)

Vinyl body side mouldings (Dart, Challenger, Charger, Coronet & Polara)

Music Master AM radio

AM radio with stereo tape cassette (Challenger & Polara/Monaco)

AM/FM radio (all except Challenger)

AM/FM multiplex stereo radio (all except Dart)

AM/FM multiplex stereo radio with cassette (Charger, Coronet, & Polara/Monaco)

Rear seat speaker

Rear window defogger

Electric heat rear window defroster (Dart Sport)

Electric deck lid release (Polara/Monaco)

Electric power door locks (Polara/Monaco)

Front bench seat with folding center armrest (Dart Custom, Dart Swinger, Dart Sport models, Coronet Custom, & Polara Custom)

Front bucket seats with integral head restraints (Dart Sport, Charger hardtop, & Charger SE)

50/50 front bench seat with recliner (Monaco)

Power windows (except Dart & Challenger)

Power steering (standard Polara/Monaco)

"Tuff" steering wheel (Charger/Coronet)

Sliding metal sun roof (Dart 2-doors & Chargers)

Sure Grip differential

Tachometer (with Rallye Instrument Cluster)

Tinted glass, all windows

3-speed floor-mounted manual transmission (Dart Sport)

4-speed manual transmission with Hurst floor-mounted shifter (Dart 340 Sport, Challenger, & Charger models)

3-speed TorqueFlite automatic transmission, column- or floor-mounted (standard Polara/Monaco)

Undercoating & hood insulator pad

Utility package, with fold-down rear seat, security panel, & trunk dress-up (Dart Sport)

Tilt "Rim Blow" steering wheel (Polara/Monaco)

Vinyl roof (all models except wagons)

Canopy vinyl roof (Dart Sport, Charger)

"Halo" vinyl roof, with bright mouldings (Charger)

Upper-level fresh-air ventilation

3-speed windshield wipers

Cornering lights (Polara/Monaco)

Trunk carpeting & carpeted spare tire cover (Polara/Monaco)

Front vent windows (4-door Polara/Monaco models only)

Wagon roof luggage rack

Tailgate power window (Coronet wagons)

Rear window cleaning vane (Coronet wagons)

Check your Dealer for additional options offered.

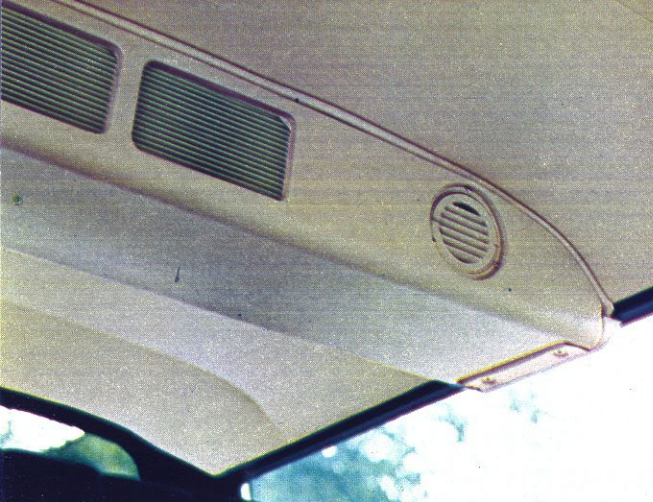

▲ Dual air conditioning ▼ Dual racing mirrors



▼ Automatic speed control

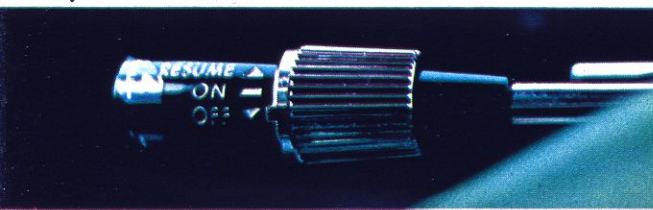

▼ Power door locks

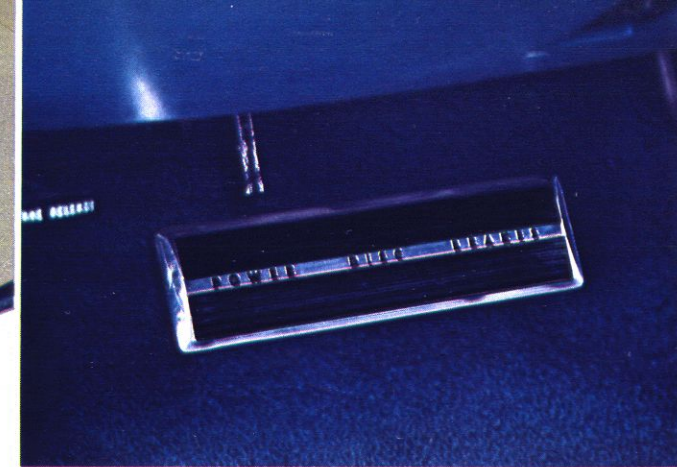
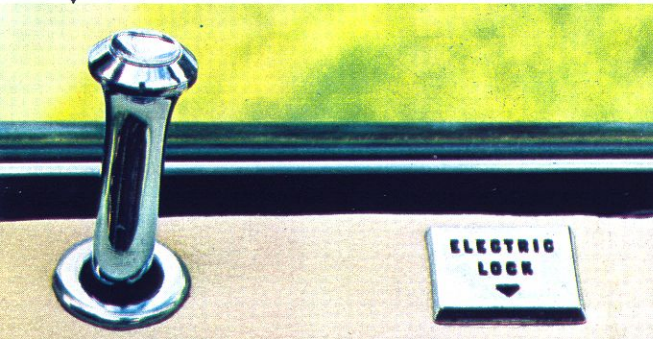

▲ Power front disc brakes ▼ Cornering lights

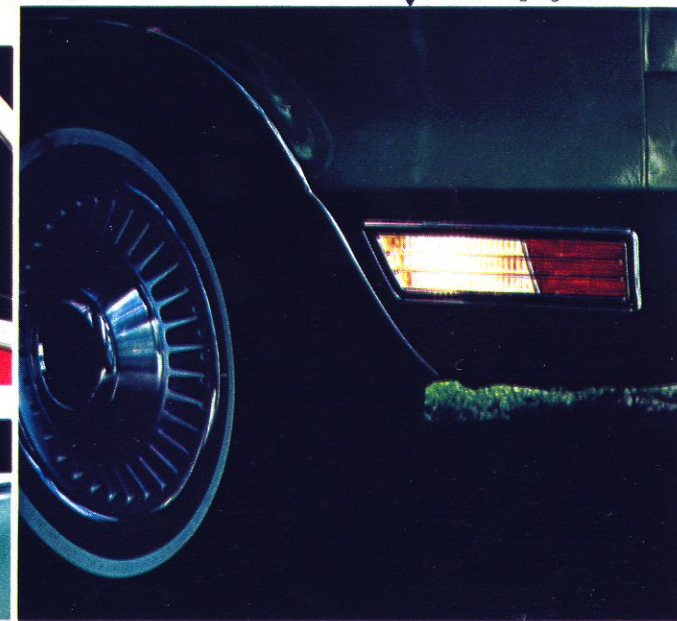

▼ Premier wheel cover

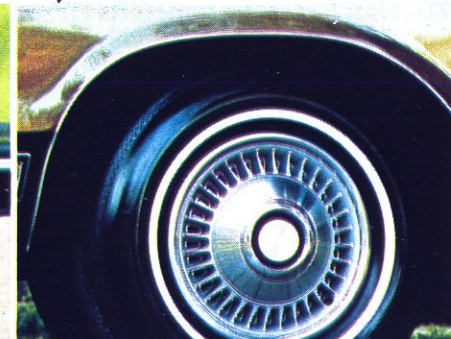

▼ Wire wheel cover



▼ Rallye wheel

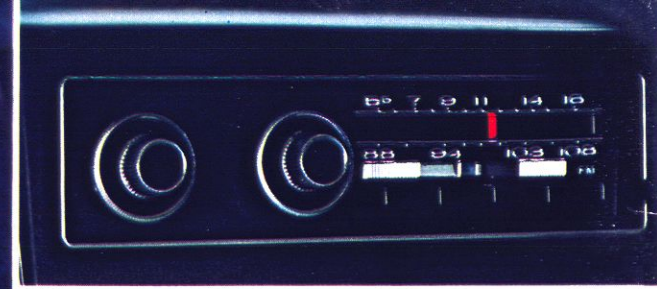

▲ AM/FM radio ▼ Air conditioning



▼ AM/FM stereo radio with tape cassette

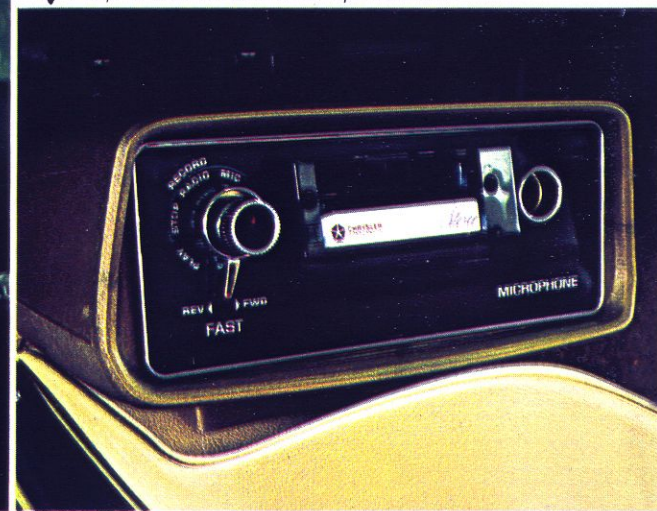

All product illustrations and specifications are based on authorized information. Although all descriptions are believed correct at publication approval, accuracy cannot be guaranteed. Some of the equipment shown on product illustrations is optional, at extra cost. Dodge Division reserves the right to make changes from time to time, without notice or obligation, in prices, specifications, colors and materials, and to change or discontinue models.

Turquoise Metallic (B)	Parchment (A)
Yellow (B)	Dark Green Metallic (A)
Dark Tan Metallic (B)	Light Blue (A)
Super Blue (C)	Bright Red (A)
Top Banana* (C)	Dark Silver Metallic (A)
Medium Tan Metallic (D)	Bright Blue Metallic (A)
Dark Blue Metallic (B)	Light Gold (A)
Pale Green (A)	Dark Gold Metallic (A)
Bronze Metallic (C)	Light Green Metallic (A)
Gold Metallic (A)	Eggshell White (A)
	Black (A)

(A) Available on all cars.
(B) Available on Polara and Monaco only.
(C) Available on Dart/Challenger/Coronet and Charger.
(D) Available on Coronet and Charger only.
*Extra-cost paint.

2-Door Models



Dart Sport.....Page 29



Dart 340 Sport.....Page 28

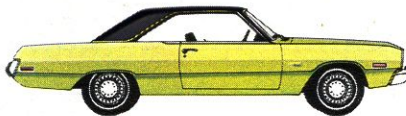

Dart Swinger Special.....Page 27



Dart Swinger.....Page 26



Challenger.....Page 25



Challenger Rallye.....Page 24



Charger Coupe.....Page 17

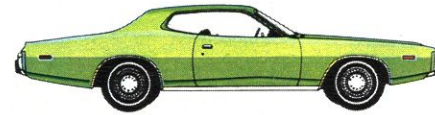

Charger Hardtop.....Page 16



Charger Rallye Coupe.....Page 18

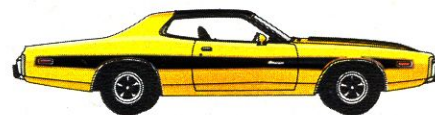

Charger Rallye Hardtop.....Page 18



Charger SE.....Page 14



Polara 2-Door Hardtop.....Page 11



Polara Custom 2-Door Hardtop.....Page 9



Monaco 2-Door Hardtop.....Page 4

4-Door Models



Coronet 4-Door Sedan.....Page 21

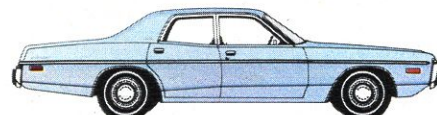

Coronet Custom 4-Door Sedan.....Page 20



Polara 4-Door Sedan.....Page 10



Polara Custom 4-Door Sedan.....Page 9



Polara Custom 4-Door Hardtop.....Page 8

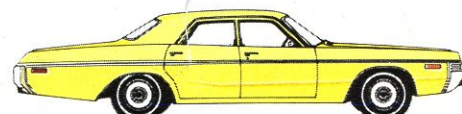

Monaco 4-Door Sedan.....Page 5



Monaco 4-Door Hardtop.....Page 5

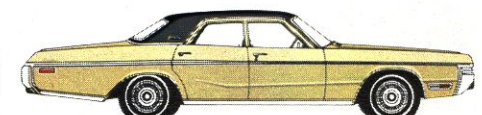

Monaco Brougham 4-Door Sedan.....Page 6

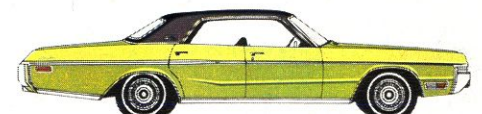

Monaco Brougham 4-Door Hardtop.....Page 6



Dart 4-Door Sedan.....Page 27

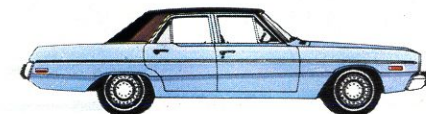

Dart Custom 4-Door Sedan.....Page 26

Station Wagon Models



Coronet Crestwood.....Page 34



Polara Custom.....Page 32

