

THE 1978 MERCURY

ZEPHYR



Mercury Zephyr 4-Dr. with Luxury Exterior Decor Option



1978 MERCURY ZEPHYR. THE CAR FOR TODAY AND TOMORROW.

Contents	
1978 Mercury Zephyr	2
Zephyr Standard Features	3
Mercury Zephyr Z-7	4/5
Zephyr Z-7 Added Features	5/6
Zephyr Z-7 Interior	5/7
Mercury Zephyr Engineering	8/9
Luxury Exterior Decor Group	10
Luxury Interior Option	11
Mercury Zephyr ES option	12/13
Mercury Zephyr Wagons	14/15
Zephyr Model Availabilities	16
Zephyr Options	16

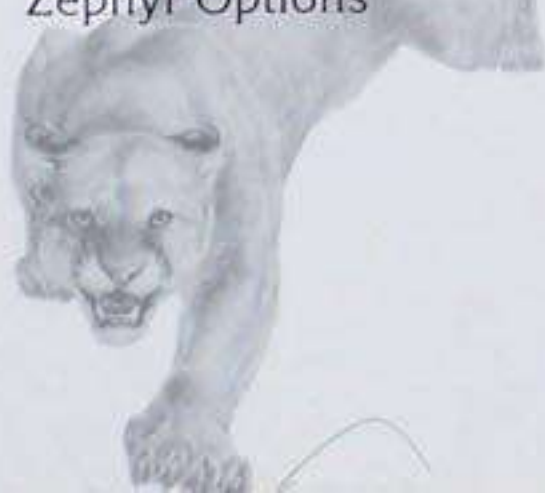

The new Mercury Zephyr, innovative in its breezy, sporty styling, is a car planned to suit the now generation of drivers. It is one of the most efficiently designed domestic cars ever offered by Lincoln-Mercury, conceived through the most extensive computer technology ever used for a Mercury.

Mercury Zephyr is energy engineered for mileage and space to provide excellent mileage and good interior roominess. EPA ratings show Zephyr at 33 miles per gallon highway and 23 city (see chart), and with more inside space than a Rolls Royce.

Mercury Zephyr is engineered for ride with a wide-mount strut suspension engineered for this new car. A totally new concept... with

computer-selected coil springs and vertically mounted rear shock absorbers.

Zephyr is engineered for precision steering with the same type of rack-and-pinion steering as many high-performance cars.

Zephyr is engineered for toughness, tough to pass the same durability tests as big Lincolns and Mercurys.

And Mercury Zephyr is engineered to help keep maintenance costs low. Our maintenance schedules show that oil and oil filter changes for the 2.3 litre engine are needed only every 10,000 miles or 12 months, spark plug replacement at 20,000 miles, and engine coolant at 50,000 miles or

Mercury Zephyr 2-Dr. Sedan



Mercury Zephyr Station Wagon with Villager and luggage rack options.



DESIGNED FOR THE ERA OF ENERGY ENGINEERING.

IMPRESSIVE ZEPHYR EPA MILEAGE ESTIMATES*

Engine/Transmission	49 States				California			
	Sedans		Sta. Wagon		Sedans		Sta. Wagon	
	H'wy	City	H'wy	City	H'wy	City	H'wy	City
2.3 Litre/Manual (Auto.)	33 (33)	23 (22)	**	**	30	20	NA	NA
3.3 Litre/Manual (Auto.)	29 (26)	21 (19)	29 (24)	19 (18)	(23)	(18)	NA	NA
5.0 Litre/Automatic	23	16	23	16	21	16	21	16

*Your mileage may vary depending on your car's condition, optional equipment and how and where you drive.
 **Availability planned for late December, 1977. See your dealer for the mileage estimates at that time.

every three years. And Zephyr's DuraSpark solid-state ignition never needs adjustment.

Mercury Zephyr's 50-plus standard features include:

- 2.3 litre OHC 4-cylinder engine
- 4-speed manual transmission
- Wiper-mounted windshield washer jets
- Inside hood release
- Front disc brakes
- Rack-and-pinion steering
- Front stabilizer bar
- DuraSpark Ignition
- Electronic

- voltage regulator
- Coolant Recovery System
- Bright anodized extruded aluminum bumpers
- Two stalk-mounted controls on steering column
- Dome lamp
- Woodtone cluster applique
- Dual horizontal headlamps and parking lamps
- Cut-pile carpeting
- Outside rear-view mirror
- Bright wheel-opening
- Rocker panel moldings
- Upper bodyside dual accent paint stripes
- Dual front fender louvers
- Deluxe wheel covers



MERCURY ZEPHYR Z-7. A THING OF BEAUTY...

Impressive. Sporty. Smart. That's the new Mercury Zephyr Z-7. Its crisp lines define classic styling in a roomy, personalized car. And Z-7 is indeed beautiful to look at with its clean functional design, highlighted by a unique roof with distinctive, wide wrap-over motif. From any angle, Zephyr Z-7 is an eye-pleaser. Its bright, vertical theme grille is crowned by a unique hood and a distinguishing "Z" ornament. Tasteful tape stripes and full-length vinyl insert bodyside moldings add a sporty elegance to

Zephyr Z-7's styling, as do its unusually large wraparound taillamps.

Zephyr's advanced strut front suspension is designed to add comfort and good road handling characteristics. Zephyr's four coil springs are computer-selected to match its weight, and help reduce the feed-back of road shock. Tuned rubber isolation components help reduce vibration through the steering system. And Zephyr has the same type of rack-and-pinion steering as many high performance cars, to give you precise, responsive steering control.

suggests the styling of fine European sedans. The Zephyr body is designed with computer analysis to provide a balance of strength and light weight. And Zephyr has a space-efficient interior, that offers surprising roominess for a car its size—comfortable seating for five passengers. In addition, Zephyr is engineered to be tough to pass the same durability tests as our big Lincolns and Mercurys.

Driving pleasure is enhanced by the surroundings in which you drive. The Z-7 interior, shown below with standard bucket seats in attractive chamois color optional cloth is also available in russet or Wedgewood



Like all Mercury Zephyrs, the Z-7 is engineered for space and toughness, as well as ride. Its efficient packaging

1978 Mercury Zephyr Z-7 2-Door Coupé



TOUCHES OF ELEGANCE. APPOINTMENTS WITH A SPORTY FLAIR.

blue. Standard upholstery for bucket seats is fine Corinthian vinyl in black, cream, as well as chamois, russet, Wedgewood blue, or white. A bench seat in Corinthian vinyl or Accent cloth in any of the named colors except white, is standard with the 3.3 litre or 5.0 litre engine, and optional with the 2.3 litre engine.

Door trim for the Z-7 is enriched with a vertical pleat design and bright accents. And the instrument panel is embellished with a woodtone applique, while the dash consists of two large round dials in black and yellow, for quick, easy reading of the instrumentation. For driver convenience, two controls are column-mounted below the deluxe steering

wheel. One provides fingertip control for turn indicator, headlight dimmer and horn, the other for windshield wiper and washer action. Also pictured below are closeups of Zephyr Z-7's bright, sculptured outside rear view mirror and Zephyr's tastefully designed hood ornament.

Mercury Zephyr Z-7 gives you most of Zephyr's standard features (see page 3), plus the following:

- Unique hood paint stripes
- Deluxe door trim
- Deluxe steering wheel
- Deluxe sound package
- Deluxe seat and shoulder belts
- Unique bodyside tape stripes
- Large wraparound taillamps
- Simulated woodgrain appliques on instrument panel
- Bright window frames
- and more.



Bucket seat interior in chamois cloth



Bright sculptured exterior rear view mirror



Mercury Zephyr hood ornament

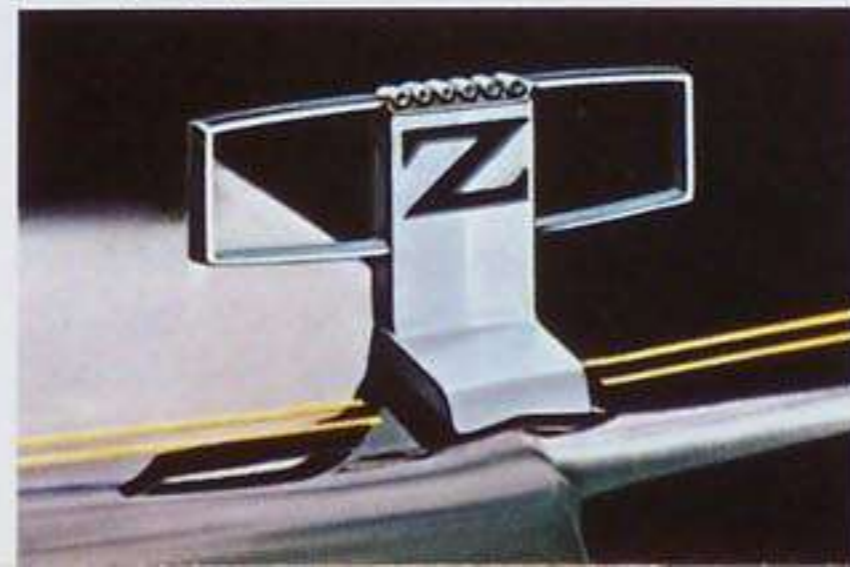

Mercury Zephyr Z-7 in Tu-tone cream and gold



MERCURY ZEPHYR Z-7. THE SPIRIT OF AMERICA ON THE GO.

Mercury Zephyr was created to serve contemporary motoring needs. And the Zephyr Z-7 is styled to reflect the spirited action of today's American life style. On the road, Zephyr's low hood and expansive glass area provide a panoramic view of the world around you as you drive. And, wherever you go, the Z-7's distinctive styling will be the object of admiring glances.

There are many ways in which you can add your own personal mark of individuality to your Zephyr Z-7. One example is the stunning effect which can be achieved through Tu-tone body color combinations. Shown above is Zephyr Z-7 in a smart optional Tu-tone cream with

gold effect. The body and roof cross-over are in cream, the lower body area and optional vinyl roof in medium gold, producing a truly exciting picture.

And there are dozens of other ways in which you can personalize your Zephyr Z-7 for added beauty, comfort and convenience. Consider these: the elegance and charm added to the Z-7 interior with the Luxury Interior Option. Air conditioning. An electric rear window defroster or rear window defogger. AM/FM stereo radio with 8-track or cassette tape. Variable ratio rack-and-pinion power steering. A 3.3 litre (200 CID) "six" or 5.0 litre (302 CID) V-8 engine. Select-Shift automatic transmission and many more options, as you'll find in the listing on the back page.

The dashing Z-7 coupé offers so much more than merely meets the eye. Its weight is practical in terms of today's needs. It is a car built with a simplified body that is still tough to pass the same durability tests as full-size Lincolns and Mercurys. Through modern technology, Ford engineers determined where added strength was needed and where weight reduction could be achieved without loss of strength. Mercury Zephyr is a car engineered for a lot more than good looks and good mileage. See page 3 for EPA estimates. Zephyr is a sportily styled car that puts the squeeze on gasoline. A car engineered for space, ride and toughness.

Mercury Zephyr Z-7 body plaque

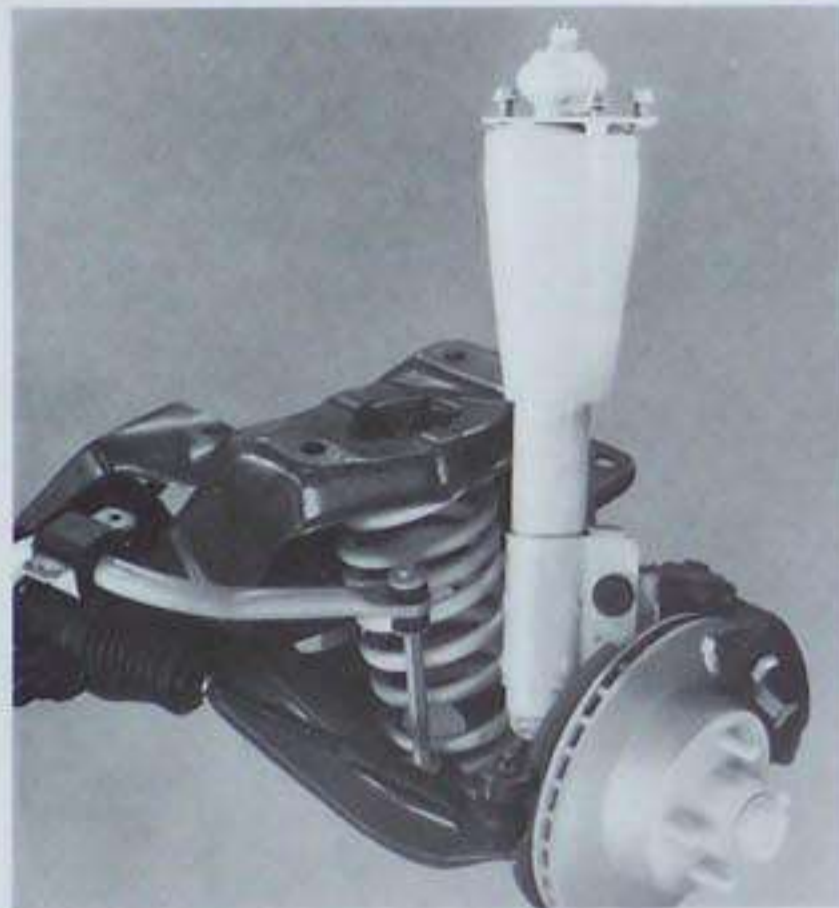
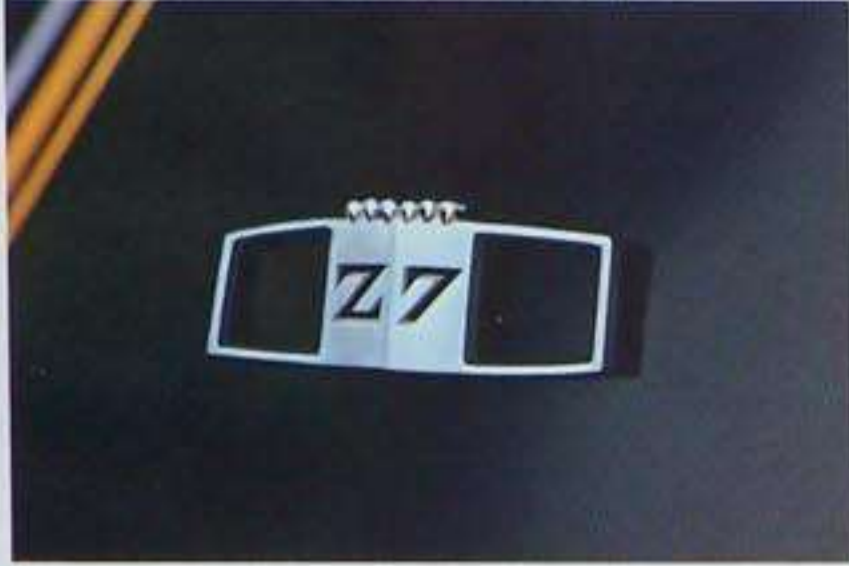

Zephyr Z-7 bucket seat interior in Corinthian vinyl

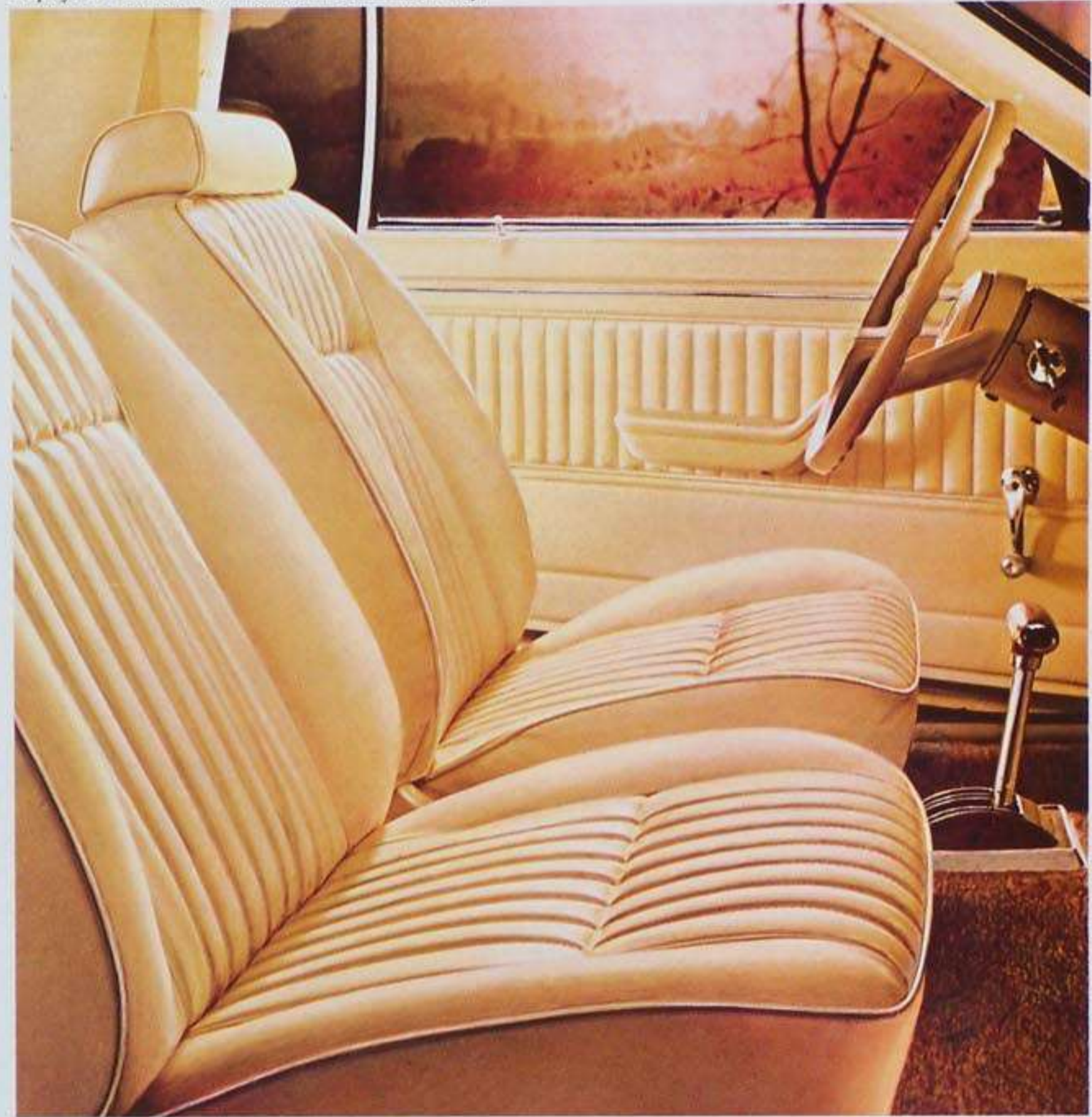

BEAUTY THAT'S MORE THAN SKIN DEEP.

The Zephyr Z-7's interior good looks match its handsome exterior. Shown above is the Z-7's standard bucket seat interior in cream color vinyl with gold trim. Other available interior color choices are russet, Wedgewood blue, black, chamois, or white with a choice of color-keyed components.

Touches that enhance the Z-7's interior include sew trim upholstery in the smart design of the Luxury Interior Accent Group and a harmonizing interior color paint at the door belt. And deluxe, color-keyed seat and shoulder belts are also standard in the Mercury Zephyr Z-7.

An exterior decorative touch that tells the world you're the proud owner of a Zephyr Z-7 is the Z-7 plaque, shown above left, which accents the handsome Z-7 cross-over roof. Also shown left is Zephyr's wide-mount

strut front suspension, which incorporates a front stabilizer bar as standard, for roll control and stability during cornering. The front suspension is isolated from the body with special rubber mountings and bushings to minimize transmission of road noise and harshness to the car's interior. Mounting of the shock absorbers close to the wheels maximizes shock absorber action when hitting a bump, thus contributing to Zephyr's ride.

Aerodynamics played a large part in producing Zephyr. A Zephyr prototype underwent more hours of wind tunnel testing before production, than any other car in Ford history. Minimization of aerodynamic drag, or wind resistance, means a rise in fuel economy, as well as improved crosswind stability and decreased wind noise.

1978 MERCURY ZEPHYR. RIDE-ENGINEERED.

Zephyr bodies were developed with the aid of computerized structural analysis and underwent more aerodynamic testing than any Ford Motor Company vehicle ever manufactured. The shape of Zephyr is classic, clean and aerodynamically sound. Its low hood, fender line, and expansive glass area mean excellent driver and passenger visibility. All suspension components are integrated to provide a steady ride over varying road conditions. And Zephyr offers diversified engine availability—four-, six- and eight-cylinder engines.

Front Suspension. Zephyr's advanced wide-mount strut-type suspension features coil springs that are mounted away from the shock absorbers to minimize road noise and harshness. The single ball joint on each side, features a rubber "doughnut" to help dampen noise and vibration. A front stabilizer bar is standard. Caster and camber adjustments are not necessary under normal driving conditions. The entire front suspension system is isolated from metal contact with special rubber mountings and bushings.

Zephyr's Dimensions	2-Door/ 4-Door Wagons		
	Z-7	4-Door	Wagons
Wheelbase	105.5"	105.5"	105.5"
Head Room, front	37.2"	38.5"	39.2"
Head Room, rear	36.3"	37.7"	39.2"
Leg Room, front (max.)	41.8"	41.8"	41.8"
Leg Room, rear (min.)	32.7"	35.4"	35.4"
Shoulder Room, front	56.7"	56.7"	56.7"
Shoulder Room, rear	57.3"	55.7/ 56.7"	56.7"
Hip Room, front	56.2"	56.2"	56.2"
Hip Room, rear	55.1"	53.7"	48.7"
Luggage or cargo capacity (cu. ft.)	16.1	16.8	79.5
Fuel capacity (gal.)	16.0	16.0	16.0
Curb weight (lbs.)	2743	2706/ 2748	2837*

*with 2.3L engine and manual transmission

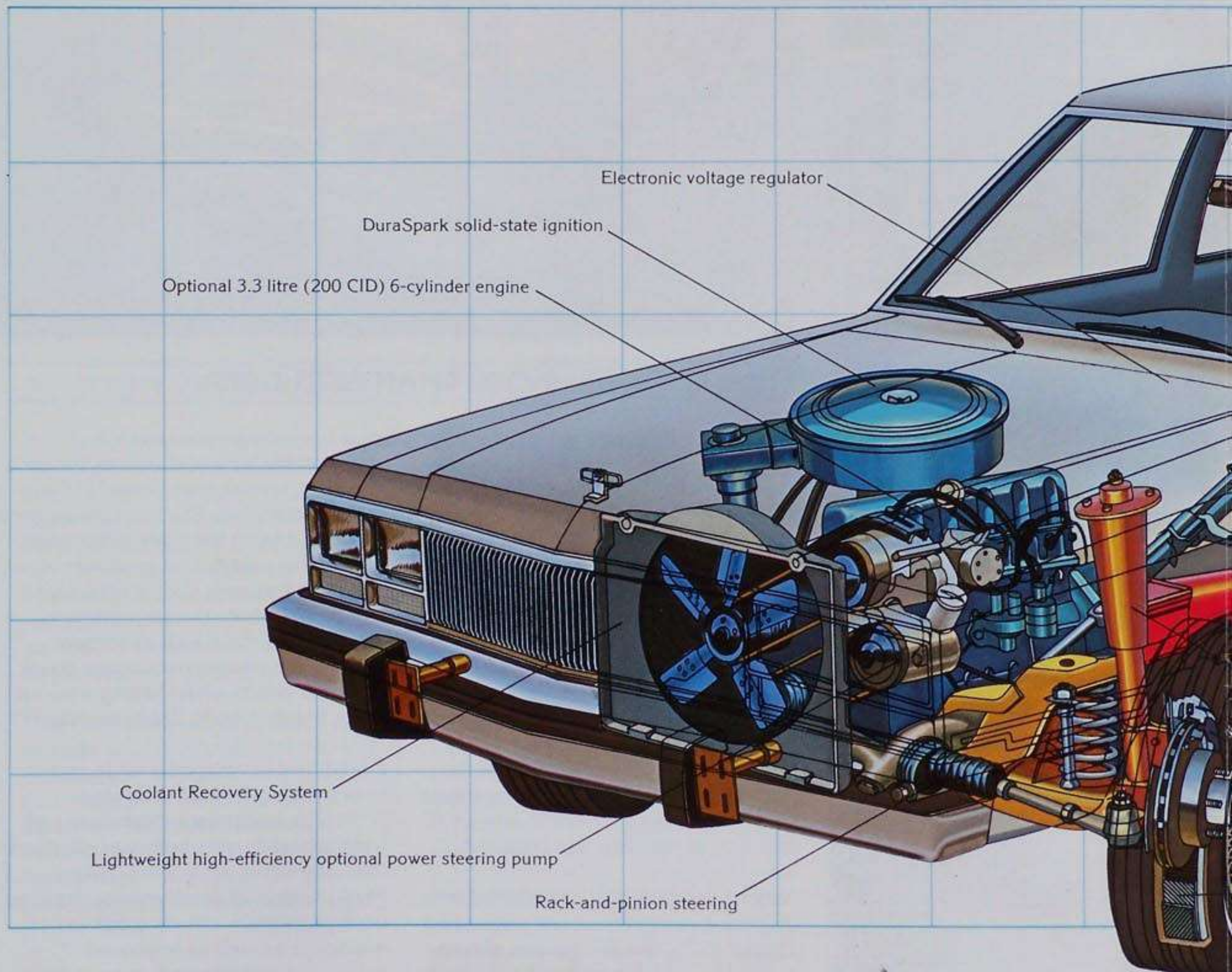



Wide-mount strut front suspension, 4-bar link coil spring rear suspension, Unitized body construction, variable ratio rack-and-pinion steering opt.

Rear Suspension. Zephyr utilizes a new four-bar link rear suspension with coil springs. It minimizes internal friction and features a handling-oriented geometry and allows for improved body design. The positioning of the links prevents axle rotation when accelerating.

Front Disc Brakes. Zephyr's pin slider-type front disc brake system with a new low-friction mounting feature is designed to improve reliability, pedal feel and reduce lining wear. A front brake lining wear indicator is also included.

Rack-and-Pinion Steering. Rack-and-pinion steering was incorporated in Zephyr's design for precise and responsive steering characteristics. Zephyr's optional variable-ratio power rack-and-pinion steering helps reduce steering effort to a minimum.

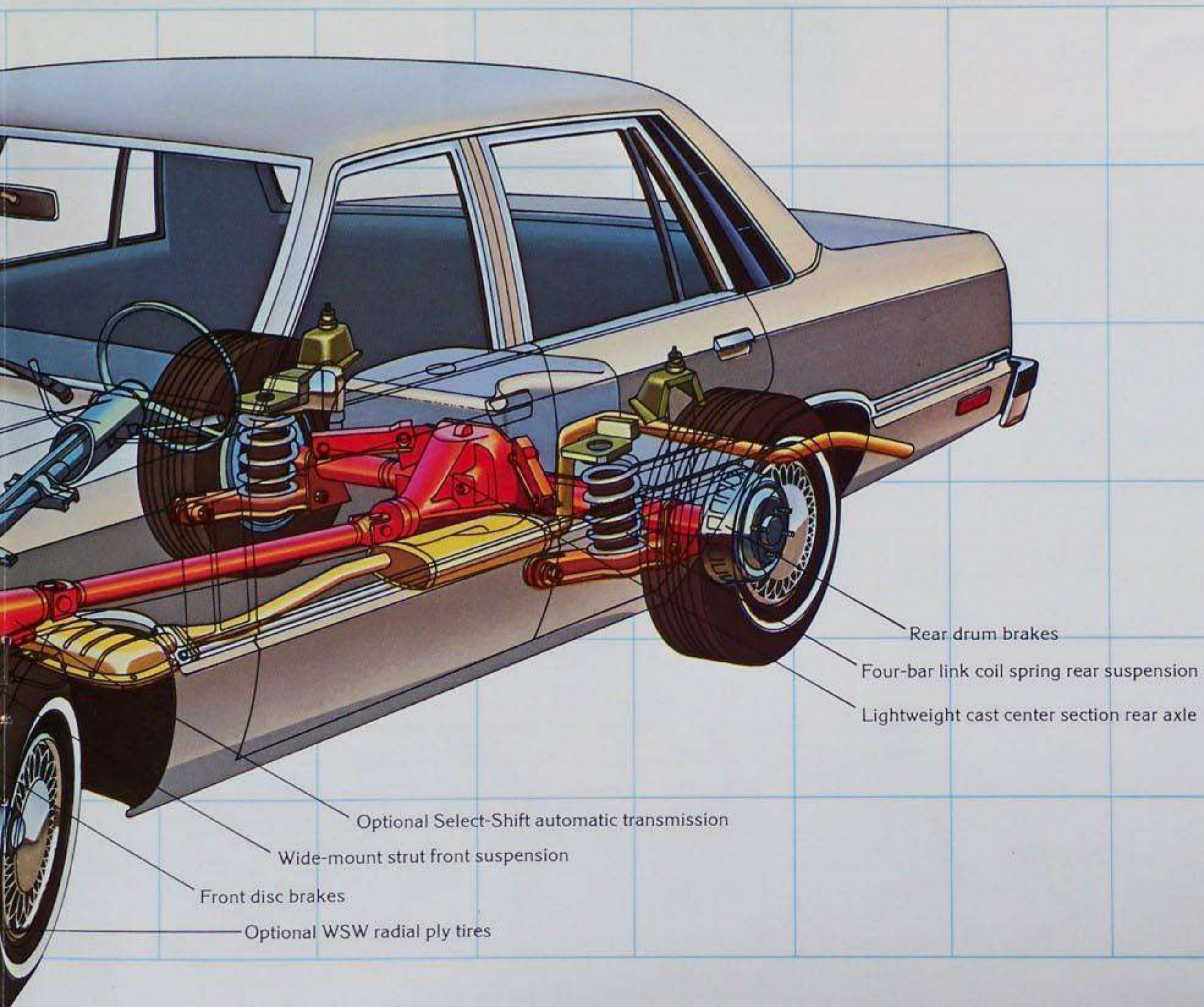

Mercury Zephyr 4-Dr. with Luxury Exterior Decor Option



1978 MERCURY ZEPHYR — ENERGY ENGINEERED FOR MILEAGE AND SPACE.

Travel in Zephyr and travel in style. It's a "now" size car for people on the move. Its exterior styling is clean, contemporary and all new. As functionally efficient as it is pleasing to the eye. But Zephyr's crisp styling and trim dimensions only hint at the comfort and room inside. The 1978 Zephyr caters to your personal tastes with four exciting models available in a variety of color-coordinated interiors finished in handsome new sew styles. Low-back front bucket seats are standard with the standard 2.3L OHC 4-cylinder engine; bench type front seats with the others. An optional Flight Bench seat with fold-down center armrest is also available. Zephyr 2-door and 4-door sedans also offer individually

adjustable optional rear window ventilation louvers for draft-free ventilation. Mercury Zephyr. Test drive the Zephyr. With contemporary styling, roominess, and a ride you won't soon forget.

Trunk design in the Zephyr sedans also reflects efficiency of space, offering 16.8 cubic feet of space, with a flat floor, and the spare tire stowed conveniently under the floor.

Zephyr's instrument panel is completely functional, featuring a two pod instrument cluster with easy-to-read instruments and all control levers within easy reach of the driver.

The new Zephyr makes it possible to dress-up your car just as you want, and exactly where you want. Interior? There's a special Zephyr Luxury Interior Option tailor made. Exterior? Zephyr also offers a special Luxury Exterior Decor Group. Both groups, of course, offer features over and above the full complement of standard features for every Zephyr, listed on page 3.

The special Zephyr Luxury Interior Option includes:

- Flight Bench seat
- Luxury sound package
- Glove box lock
- Deluxe steering wheel and hub
- High-gloss woodtone instrument panel applique

Flight Bench seat option in Wedgewood blue



Standard 2.3 litre engine



Mercury Zephyr instrument panel



Mercury Zephyr interior roominess



MERCURY ZEPHYR LUXURY DECOR GROUPS.

- Inside day/night mirror
- Luxury door trim panel including carpeted lower portion
- Luxury carpeting
- Carpeted luggage compartment—Liftgate carpeted on wagons
- Deluxe seat and shoulder belts
- Bright door hardware accents
- Visor vanity mirror
- Cigar lighter
- Two rear seat ashtrays

The new Zephyr Luxury Exterior Decor Group includes the following:

- Dual accent hood paint stripes
- Deluxe bodyside protective molding
- Dual rear view mirrors—left-hand remote control/right-hand convex non-remote
- Bright door frame and quarter window moldings

Make no mistake, Zephyr can be as luxurious as you please. In addition to a long list of exterior refinements, its Luxury Interior Option features such things as a Flight Bench seat, shown in Wedgewood blue Shannon cloth, deluxe steering wheel, luxury carpeting, and high-gloss woodtone instrument panel appliques. We believe Zephyr's interior roominess will please you. In both 2-door and 4-door models headroom is 38.5 inches front, and 37.7 inches rear. And there's 41.8 inches of stretch-out leg room in front, 35.4 inches in the rear compartment. And rear seating comfort is enhanced by the thin-back design of Zephyr's front bench seat, standard, with six- and eight-cylinder engines. Bucket seats are standard with the 2.3 litre engine.

1978 MERCURY ZEPHYR: ALL NEW AND INNOVATIVE IN DESIGN.

The new Zephyr was planned, inside and out, to be what today's driver needs in an automobile in light of today's requirements. Roomy for a car its size. The very name, Zephyr, usually signifying a gentle, fresh breeze, appropriately describes this new Mercury, created to answer today's demands for personal transportation. Zephyr's fresh design is dramatically expressed in its unique dual horizontal headlamps positioned over dual horizontal parking lamps, a feature exclusively Zephyr's in its class. With its innovative modern approach to design, it offers you a desirable choice in an efficient, easy-to-own-and-operate size automobile.

With Zephyr you also have a wide choice of models. Two- and four-door sedans, with option groups to enhance luxury levels to your taste and budget. A smartly styled Z-7 coupé. A fine Station Wagon that also offers a higher luxury-level choice in the Villager Wagon Option. In its interior and exterior, Zephyr was created to be the kind of automobile you've been waiting for. The kind of car ideal for young people on the go as well as for families that enjoy doing things together.

You are invited to discover for yourself the many automotive virtues

of Zephyr, to see first hand just how a new Zephyr will fit into your life style. Visit your Lincoln-Mercury dealer and test drive the Zephyr of your choice. Check out its various levels of luxury. Its practical size.

If your desire in a car extends to an exciting "different" look—to the eye-catching flair of an expensive foreign road sedan—give serious thought to the Zephyr ES option. Its special styling touches include smart black exterior accents on grille, cowling, mirrors and window frames.

We believe you'll find the ES option an exceptional value in sporty fun. The special styling touches in black

Mercury Zephyr 2-Dr. Sedan and Mercury Zephyr 2-Dr. Sedan with ES option—4-Dr. ES option also available



MERCURY ZEPHYR WITH ES OPTION.

give Zephyr with the ES option a look of excitement, symbolizing the spirited action of today's on-the-go life style. The ES option makes your Zephyr a visual expression of your appreciation for the unusual in automotive good looks.

Pictured below is the intriguing black/chamois combination interior for the ES option. Steering column and sports steering wheel are in black. So, too, the instrument panel. Carpeting and armrests are black. Black accents are on the doors. Functional features include a rear

stabilizer bar and special suspension tuning. Mercury Zephyr is all the more exciting when you equip yours with the ES option.

16.8 cubic feet of trunk space in 2- and 4-Door Sedans



Mercury Zephyr lets you exercise your options with a choice of exciting interior combinations. The ES option interior shown below features low-back bucket seats finished in soft, supple chamois vinyl. Another handsome option shown is the bucket seat combination in Wedgewood blue Logan cloth-and-vinyl. Other available interior colors are russet, black, white and chamois. The steering column-mounted wiper/washer, turn signal, headlamp dim switch and horn are touches of convenience you'll find in every Zephyr. We believe the 1978 Zephyr is a great car.

Mercury Zephyr 2-Dr. Sedan with ES option



Rear window ventilation louvers



Bucket seat option in chamois and black vinyl

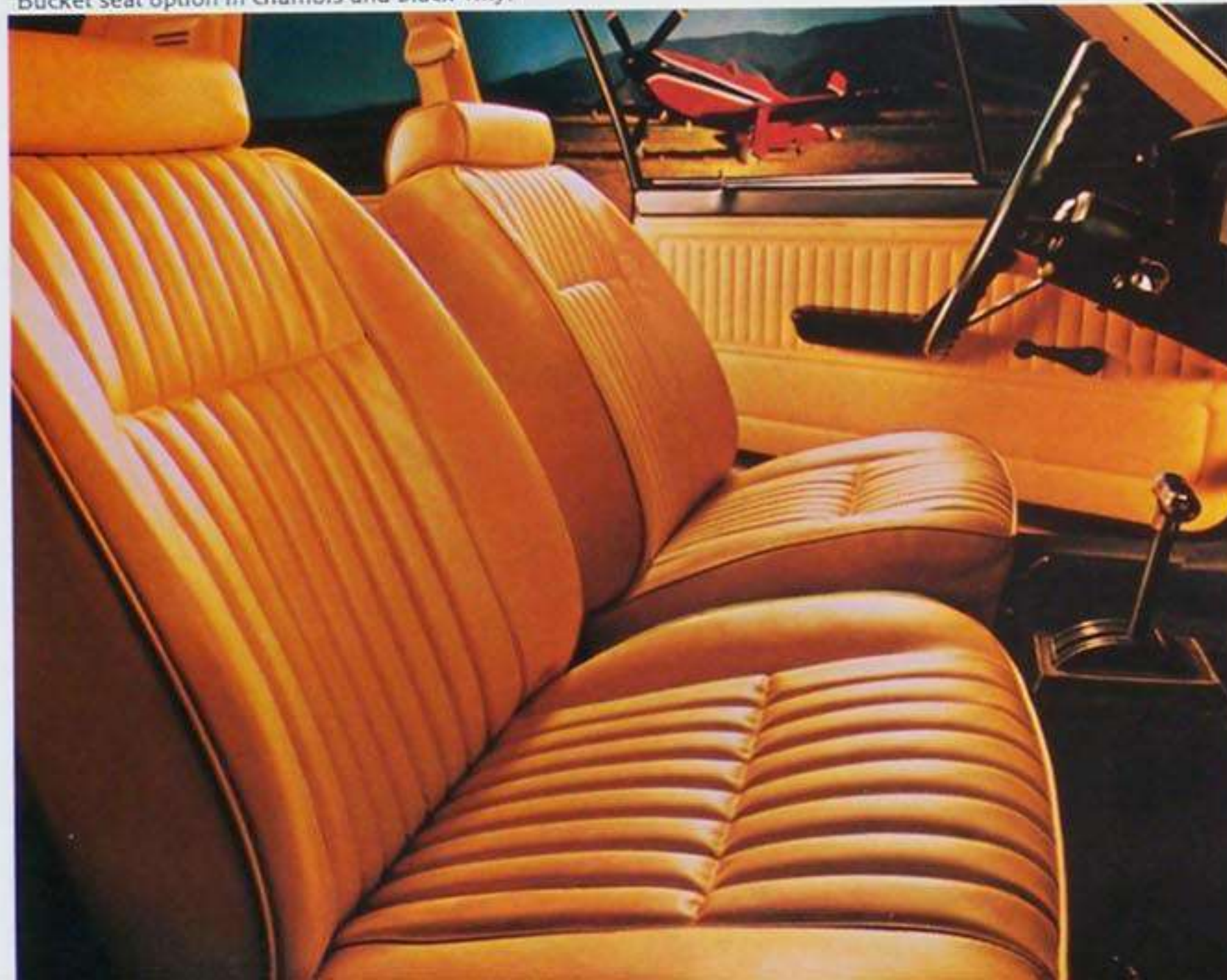

Bucket seat option in Wedgewood blue Logan cloth



Steering column stalk-mounted controls



1978 MERCURY ZEPHYR 4-DOOR STATION WAGON.

Mercury Zephyr is ideal for family fun and togetherness, especially when the choice is a 1978 Zephyr wagon. It's ride-engineered like all Mercury Zephyrs. This family-oriented wagon comes with Zephyr's advanced wide-mount strut front and coil spring rear suspension . . . popular 2.3 litre overhead cam 4-cylinder engine . . . precise rack-and-pinion steering . . . and more than 6 1/2 feet of load length with the second seat folded down. Convenience features, too, such as the "Liftgate Open" warning light and cargo area light standard.

For an added touch of luxury in a Zephyr station wagon, choose the Zephyr wagon with Villager Option.

It's a family dream, ideal for those trips into the great outdoors. So much room for stretch-out comfort, and with the second seat folded down there's 79.5 cubic feet of cargo space to carry picnic baskets, sports equipment, whatever. Zephyr also offers additional space with its optional lockable stowage compartment. The Zephyr Villager is fitted with special features of note that include exterior beauty from woodtone bodyside and tailgate appliques in a medium cherry color. Bright moldings, too, with woodtone inserts surrounding bodyside and liftgate appliques. And bright door frame and rear window moldings. All in addition to the extensive list of standard Zephyr features.

And if you're taking your kids to a Little League game you'll really appreciate Zephyr's roominess.

You'll be pleased with Zephyr's soft, supple, but very practical vinyl upholsteries. And you have such a wide choice of colors. Shown below right is the Luxury Interior Option featuring the Flight Bench seat interior in chamois vinyl, a luxurious seating for a station wagon. The standard Zephyr front seat is shown below in russet vinyl.

And Zephyr has the answer on how to keep the rear liftgate window clean without stopping. It's the optional liftgate window wiper/washer that

Mercury Zephyr Station Wagon with Villager Option and Mercury Zephyr Wagon



MERCURY ZEPHYR. ROOMY. VERSATILE.



Station Wagon interior with standard bench seat

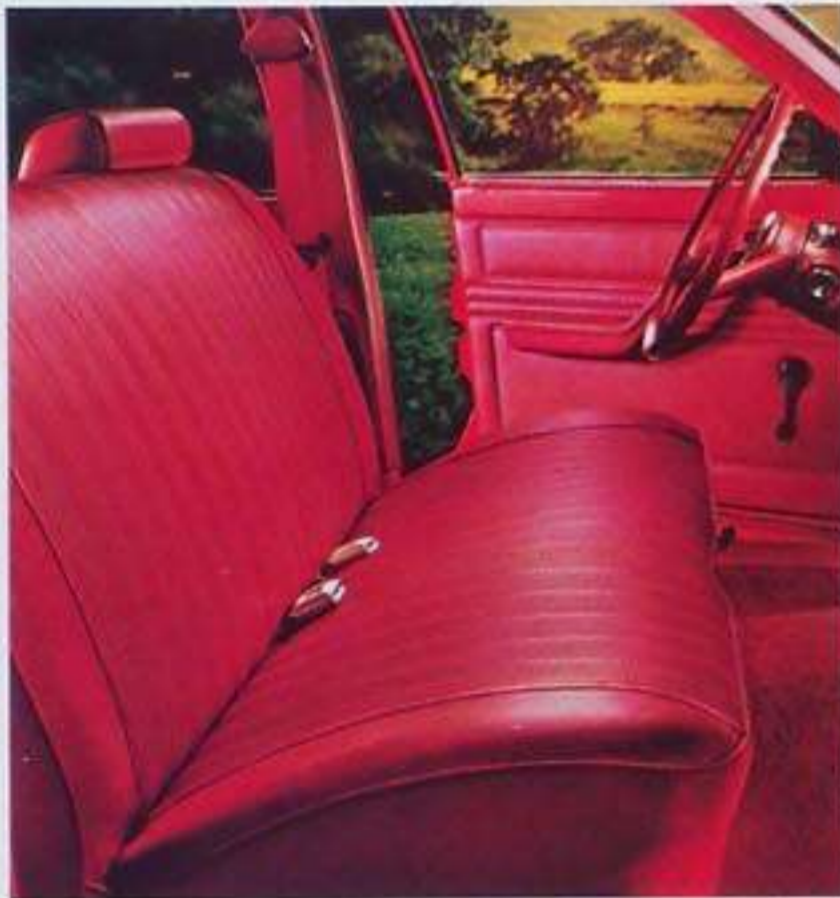

really does the job of cleaning the rear window to help provide rear visibility in a rainstorm. And Zephyr offers many more optional features that add to your comfort and convenience, as well as your pleasure on the road.

Choose from six audio systems available for Zephyr, including the AM/FM stereo radio with cassette tape, shown below, and keep yourself and the family pleasantly entertained. Also keep them in comfort whatever the weather with Zephyr's optional air conditioner. And there's an optional roof-mounted luggage rack to carry extra cargo. You can outfit your Zephyr wagon—or any Zephyr to suit your personal tastes.

Zephyr's efficiently designed station wagon cargo space provides room for all manner of luggage, sports equipment, bulky crates—whatever. With the spare tire stowed under the cargo floor, you have 79.5 cubic feet of space for your cargo needs.

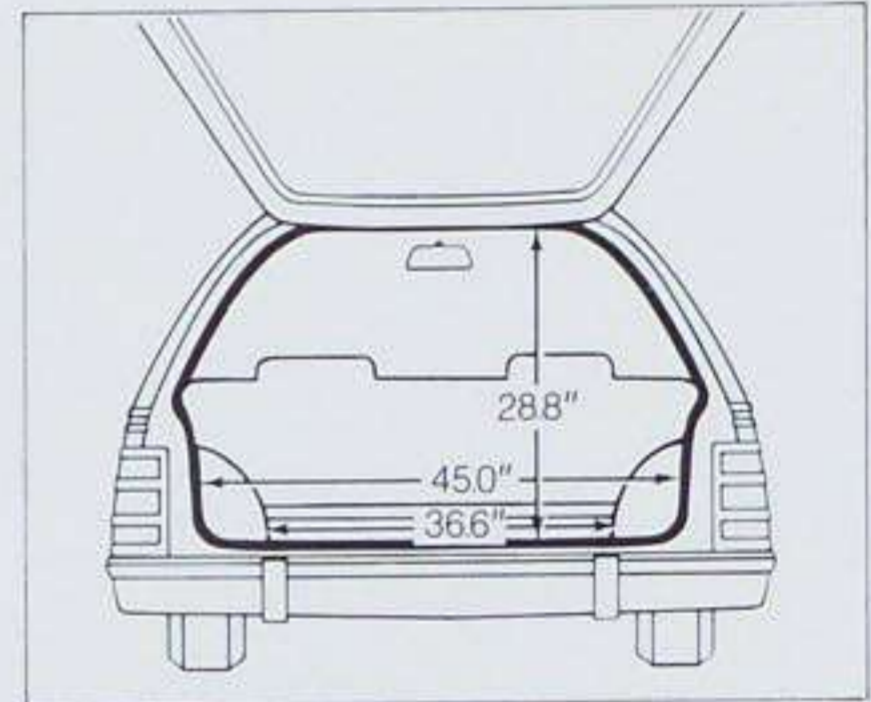

Station Wagon interior with Flight Bench seat option



Wiper-mounted washer jets

AM/FM stereo w/cassette tape

Zephyr Station Wagon cargo space



THE 1978 MERCURY ZEPHYR CAR AVAILABILITIES:



Mercury Zephyr Z-7 Coupé



Mercury Zephyr 2-Dr. w/Luxury Exterior Decor Option



Mercury Zephyr 4-Dr. w/Luxury Exterior Decor Option



Mercury Zephyr 2-Dr. w/ES option (4-Dr. also avail.)



Mercury Zephyr 2-Dr. Sedan



Mercury Zephyr 4-Dr. Sedan



Mercury Zephyr Station Wagon w/Villager Option



Mercury Zephyr Station Wagon

1. Includes visor vanity mirror, cigar lighter and rear seat ashtray (one in 4-door and S/W with bench seats; two in all others), day/night inside mirror, deluxe color-keyed seat belts and glove box lock. Included in the Luxury Interior Option.
2. Required in New York unless Electric Rear Window Defroster specified. NA on wagons.
3. Includes pleated vinyl seat trim, deluxe door trim with bright accents, deluxe steering wheel hub, instrument panel woodtone applique (except with ES option), deluxe sound package and interior color paint at door belt (except with ES option).
4. Includes these lights: luggage compartment, (sedans and Z-7), ashtray, glove box, engine compartment, rear door courtesy switches (4-dr. models), map light and passenger door courtesy switch.
5. Located in driver's side rear quarter panel.

ZEPHYR POPULAR OPTIONS

AVAILABILITY

PERFORMANCE RELATED

	Zephyr Sedans	Zephyr Wagon	Zephyr Z-7
3.3 litre (200 CID) 1V 6-cylinder Engine	X	X	X
5.0 litre (302 CID) 2V V-8 Engine	X	X	X
California Emissions System (Req. in California)	X	X	X
Select-Shift Automatic Transmission	X	X	X
Floor-Mounted Transmission Selector	X	NA	X
Battery, Heavy-Duty	X	X	X
Suspension, Handling	X	NA	X

COMFORT & CONVENIENCE

Air Conditioning, Manual control	X	X	X
Clock, Electric	X	X	X
Convenience Group (1)	X	X	X
Defogger, Rear Window (2)	X	NA	X
Defroster, Electric Rear Window	X	X	X
ES option (see page 12)	X	NA	NA
Interior Accent Group (3)	X	X	Std.
Light Group (4)	X	X	X
Lower Bodyside Protection	X	X	X
Luggage Rack, Roof-Mounted	NA	X	NA
Luxury Exterior Decor Group (see page 10)	X	NA	NA
Luxury Interior Option (see page 11)	X	X	X
Louvers, Rear Window Ventilation	X	NA	NA
Mirrors, Dual	X	X	X
Molding, Protective Bodyside	X	X	NA
Molding, Bright Window Frame	X	X	Std.
Paint, Glamour	X	X	X
Paint, Tu-Tone	X	NA	X
Power Disc Brakes	X	X	X
Power Door Locks	X	X	X
Power Seat	X	X	X
Power Steering	X	X	X
Radio, AM	X	X	X
Radio, AM w/Stereo Tape	X	X	X
Radio, AM/FM Monaural	X	X	X
Radio, AM/FM Stereo	X	X	X
Radio, AM/FM Stereo w/8-Track Tape	X	X	X
Radio, AM/FM Stereo w/Cassette Tape	X	X	X
Roof, Vinyl	X	NA	X
Steering Wheel, Sport	X	X	X
Stowage Compartment, Lockable (5)	NA	X	NA
Tinted Glass, Complete	X	X	X
Villager Option (see pages 3 and 14)	NA	X	NA
Wheel Covers, Styled	X	X	X
Wheel Covers, Wire (see page 2)	X	X	X
Wheels (4) Aluminum (see page 12)	X	X	X
Wiper/Washer on Liftgate Window	NA	X	NA
Windshield Wipers, Interval	X	X	X
Windows, Front Vent	X	X	NA

X—Available Std.—Standard NEC—No Extra Charge NA—Not Available
The above is only a partial list of options. See your dealer for a complete list. Some options have restricted availability or require other options as a requirement of availability. See your dealer for details.

Motorcraft 



TESTED TOUGH

Quality Replacement Parts from Ford—Your new Mercury comes equipped with factory engineered and approved parts including a dependable Motorcraft battery, Autolite Power-Tip spark plugs, Motorcraft shock absorbers, ignition parts and Long Life oil filter. For continued top performance be sure to specify genuine Motorcraft parts whenever replacement is necessary.

Lincoln-Mercury Division reserves the right to discontinue or change specifications or designs at any time, without incurring any obligations. Some features shown or described previously are optional equipment items which are available at extra charge. Some options are required in combination with other options.

**MERCURY
ZEPHYR**

LINCOLN-MERCURY DIVISION

