

1983
CHRYSLER
E CLASS



E CLASS

STEWART M. DUHIG
OF ED BARWICK
CHRYSLER - PLYMOUTH
VOLVO -
PH. 224-3166 - ASK FOR DUKE

1983 CHRYSLER E CLASS.

Chrysler's largest front-wheel drive sedan.

Chrysler E Class, America's newest front-wheel drive automobile, offers a highly desirable combination of six-passenger room, outstanding ride and handling, and superb styling— all in an efficient, contemporary size.

Appointed with a wealth of fine touches, the Chrysler E Class sedan rests on a 103-inch wheelbase to offer excellent overall interior roominess that includes a spacious rear seat. It also carries a deep 17-cubic-foot trunk.

But sleek good looks, adult-size room, comfort, and an extra-smooth ride alone do not make Chrysler E Class a car that is unquestionably right for the times. The key element is its efficiency on the road. It is powered by a fuel-efficient Chrysler-built 2.2-liter Trans-4 engine coupled to a smooth three-speed automatic transaxle. Chrysler E Class sedan is rated at **24** EPA EST MPG;* 32 estimated highway. Our latest example of our front-wheel drive technology—Chrysler E Class—represents a lot of value with a lot of class. Come experience it for yourself.

*Use EPA EST MPG numbers for comparison. Your mileage may differ depending upon speed, weather, and trip length. Actual highway mileage will probably be lower than highway estimate. California: **24** EPA EST MPG; 32 estimated highway.

About this catalog. We have tried to make this catalog as complete as possible. And we hope you find it useful. However, since the time of printing, some of the information you'll find here may have been updated. Your dealer has details, and you should ask him for current information before ordering.

Some of the equipment shown or described throughout this catalog is available at extra cost.



Chrysler E Class four-door sedan, shown in Crimson Red.

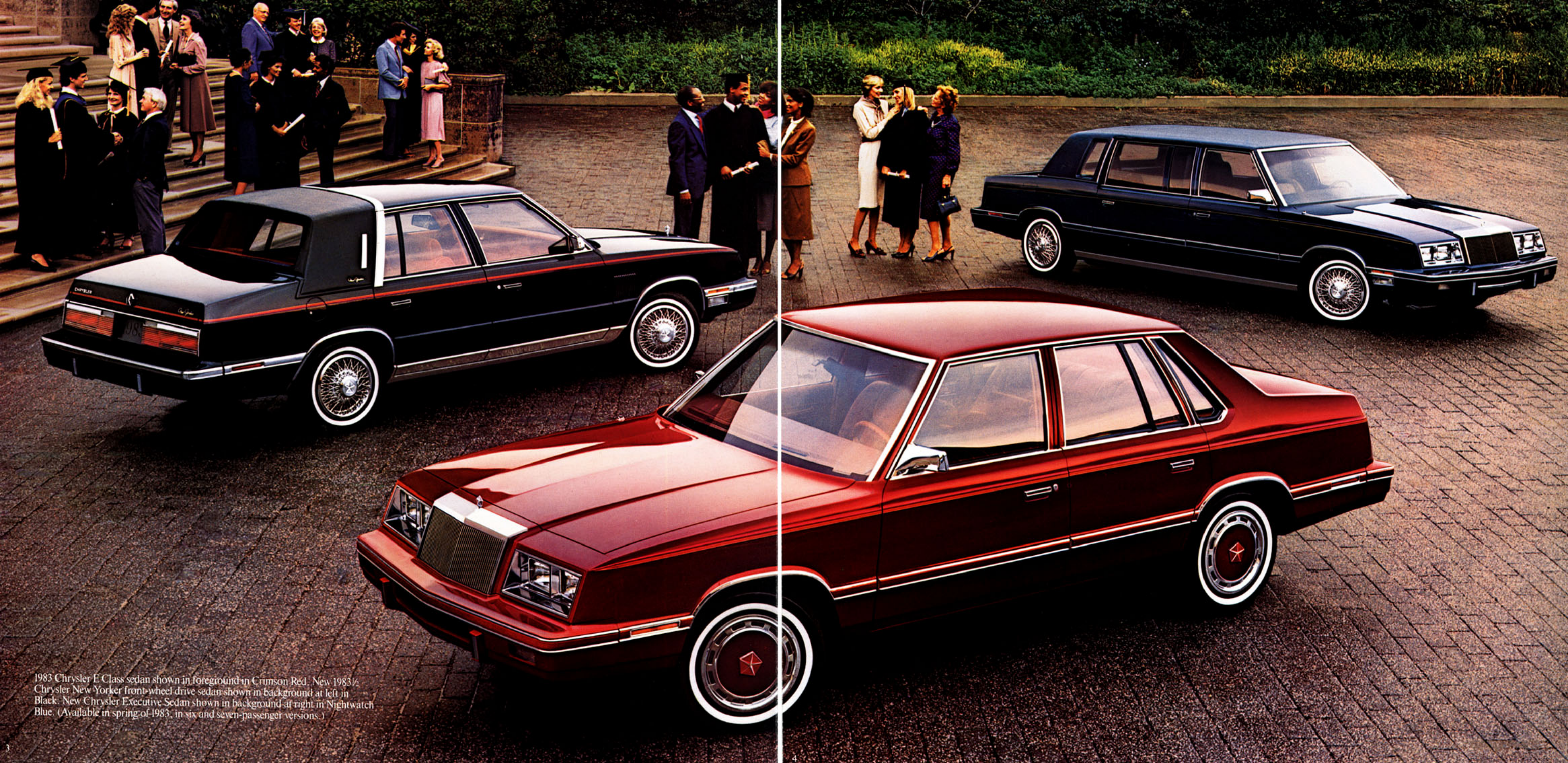

1983 Chrysler E Class sedan shown in foreground in Crimson Red. New 1983 1/2 Chrysler New Yorker front-wheel drive sedan shown in background at left in Black. New Chrysler Executive Sedan shown in background at right in Nightwatch Blue. (Available in spring of 1983, in six and seven-passenger versions.)

Chrysler E Class standard padded instrument panel and cluster, shown in Red with two-tone woodtone treatment and with optional air conditioning, electronically tuned AM/FM stereo radio, and Electronic Travel Computer cluster.

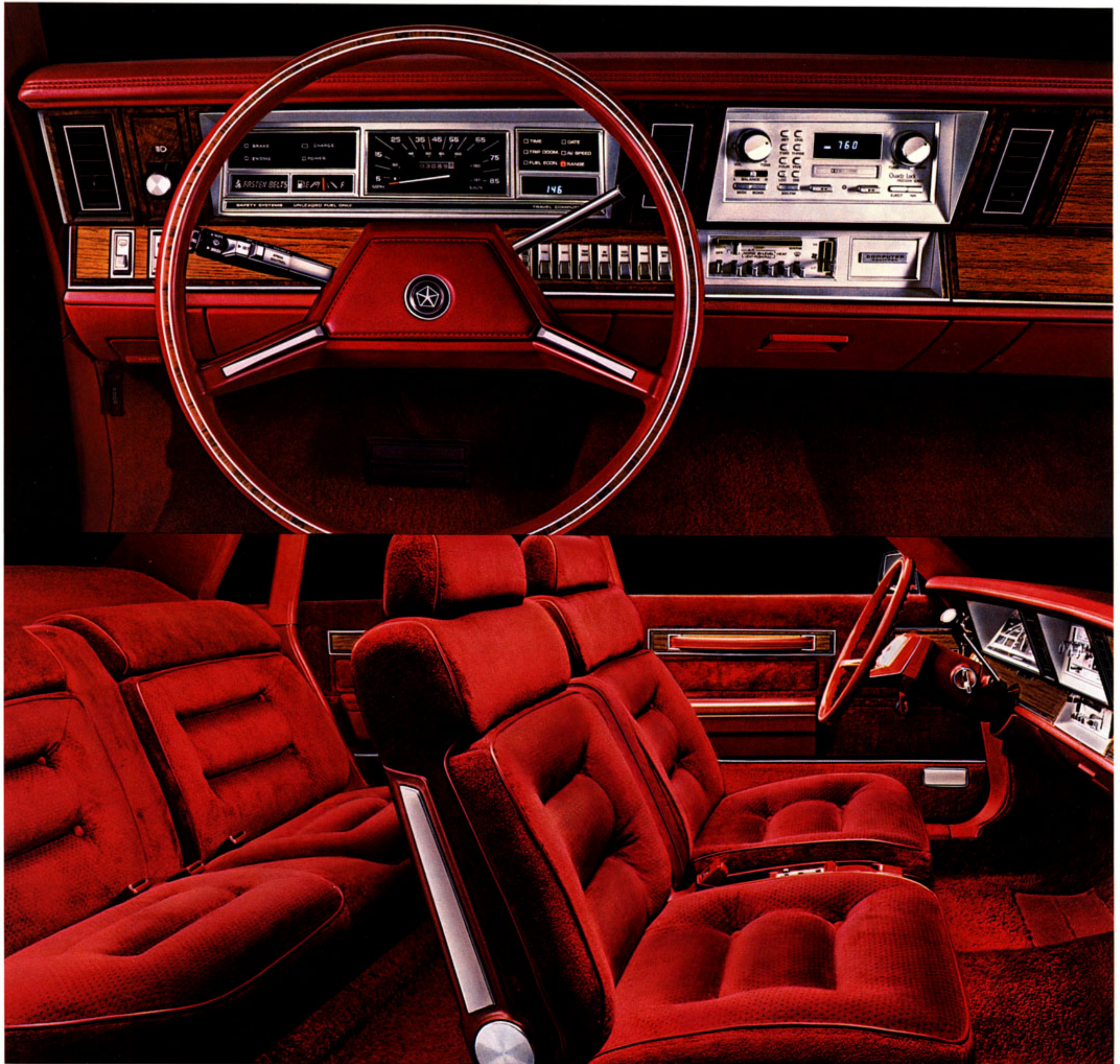

Optional 50/50 cloth bench seat with dual armrests, dual recliners, seat-mounted center console with seat controls, seatback storage pockets, and cloth-covered door trim panels. Shown in Red.



Chrysler E Class four-door sedan, shown in Nightwatch Blue/Glacier Blue Crystal Coat two-tone.

Standard cloth interior with center armrest bench seat and cloth-covered door trim panels. Shown in Blue.



Chrysler E Class sedan. It gives generously.

It's immediately apparent that Chrysler E Class is a new kind of car. Its efficient size doesn't sacrifice the amenities of contemporary design. Its luxury grille and sculptured hood are distinctive. Dual rectangular halogen headlamps and bumper-mounted park and turn lamps add practicality to its appearance.

Road-ready value is what Chrysler E Class is mostly about. Inside, it is obvious everywhere you look. Its standard Electronic Voice Alert System audibly tells you of the car's condition when the ignition key is inserted. It will let you know that all systems are "OK," or that a door is ajar or fuel is low. There are eleven different messages in all. Thick cut pile carpeting abounds throughout. Even the trunk floor is fully carpeted. Digital electronic clock and AM radio are both standard. So, too, is a luxury steering wheel.

Chrysler E Class has ride and handling characteristics that are smooth and precise. Standard precision controlled suspension with Iso-Strut coil springs up front and flex arm beam axle at the rear soaks up road shocks. Power steering and power brakes are standard. Standard ride control steel-belted radial ply tires and a quiet Sound Control Package add to your driving pleasure.

Real value is the result of Chrysler Corporation's confidence in its quality procedures. Because of this confidence, upon expiration of the normal 12-month/12,000-mile new vehicle limited warranty, limited warranty coverage is extended on power train components, including engine, transaxle and axle—plus outer body rust-through protection—to five years/50,000 miles, whichever comes first.

Value is further enhanced with more standard features such as electric fuel filler door release, dual outside bright mirrors, and electric deck lid release.

STEWART M. DUHIG
OF ED BARWICK
CHRYSLER - PLYMOUTH
VOLVO -
PH. 224-3166 - ASK FOR DUKE

Front-wheel drive. Engine and trans-axle drive front wheels through two short drive shafts. Permits reduction of floor tunnel in the body for greater interior roominess.

Iso-Strut front suspension. Independent coil spring and strut suspension with integral linkless antisway bar. Completely rubber-isolated from the car body.

Electronic feedback carburetor. Oxygen sensor monitors combustion gases to maintain ideal carburetor fuel-air mixture for best combustion efficiency.

Chrysler-built TorqueFlite automatic transaxle. Features wide-ratio gears, with high-ratio first and second gears for good acceleration without loss of fuel economy.

Power-assisted rack-and-pinion steering. Provides positive responsive steering with low turning effort, good returnability, and excellent directional stability.

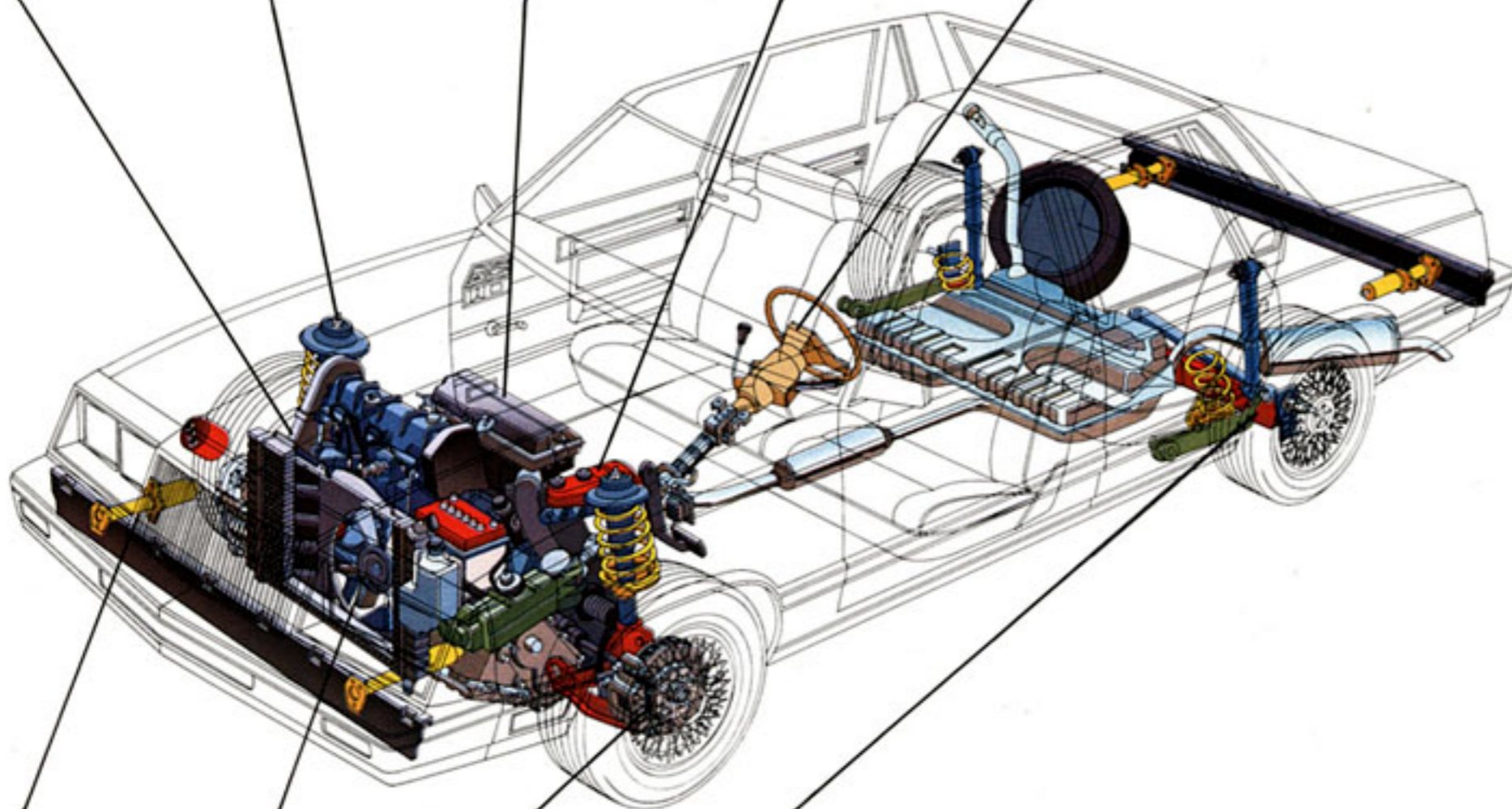

Bumper system. Engineered to exceed federal regulations while blending with Chrysler E Class luxurious styling.

Chrysler-built 2.2-liter Trans-4 engine. More powerful with increased horsepower and higher torque. The intake manifold and intake and exhaust valves have been redesigned. The result is high performance and efficiency.

Power brakes. Front disc brakes have large rotor and caliper assemblies. Rear drum brakes are now self-adjusting. Stops are safer and sure.

Trailing arm rear suspension. Features beam axle with trailing arm suspension system with coil springs, adjacent shock absorbers, track bar, and a torsion-tube anti-roll control for a smooth, even ride.

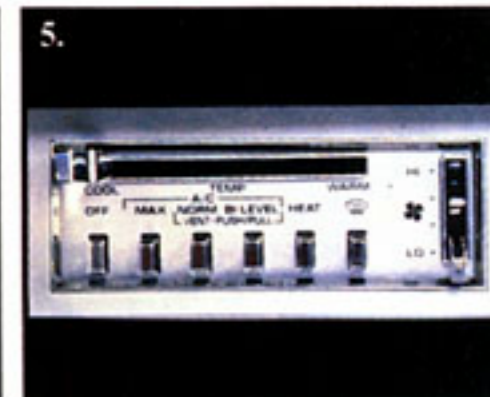

Design has a lot to do with the sophisticated formula that makes front-wheel drive technology work so well in the 1983 Chrysler E Class sedan. Not just make-it-look nice styling, but aerodynamic styling that uses the flow of the air to hold the car to the road while maximizing engine power and fuel efficiency. Chrysler E Class sedan's aerodynamic styling allows it to cruise at 50 miles per hour while using only 14.1 of its 94 total horsepower.

Quality is another key ingredient in Chrysler's formula for success. Contributing

to Chrysler's ability to offer 5/50 outer panel rust-through protection is the fabrication of the unitized body with the extensive use of galvanized sheet metal panels, one of the best known methods of corrosion protection, and pre-coated steel along with a seven-step dip-and-spray process. Cars are checked constantly during assembly to make sure parts fit and systems work.

Size up the new Chrysler E Class sedan for yourself. Check the quality. We know you'll find it high because we've already checked it...many times.

Pictured Options.

1. Electronically Tuned AM/FM Stereo Radio with Cassette Player. Precise solid state tuning without fade or drift. Fluorescent digital display and a memory system. Available with or without cassette tape player with Dolby* sound. *Dolby is a registered trademark of Dolby Laboratories.

2. Tilt Steering Wheel. Adjusts to six different positions for personal comfort. Provides easy entry and exit.

3. Power Remote Sideview Mirrors. Remote control power lever to adjust outside left and convex right outside mirrors.

4. Electronic Travel Computer Cluster. Digital display that supplies pertinent trip data at a touch. Includes fuel range and present mpg rate, trip odometer, average speed since reset, date, time, and a U.S./metric unit selector.

5. Air Conditioning with Bi-Level Ventilation. Improves the flow of cool, clean air, helps provide more even temperature, and reduces cold drafts.

6. Vanity Mirror. Handy illuminated passenger side visor vanity mirror adds even more luxury.

7. Automatic Speed Control. Helps make highway driving easier and saves gas on long drives. Control is located on the standard steering column multifunction control lever.

Optional Equipment

Certain models, packages, and options are subject to specific restrictions, requirements, and late availability. Consult your dealer for current ordering information.

- Air Conditioning—With bi-level feature (see engine cooling)
- Battery—500-amp maintenance-free: heavy-duty
- Bumper Guards—Front and rear
- Coating—Lower body: protective vinyl
- Computer Cluster—Travel: electronic
- Defroster—Rear window: electrically heated (required at extra cost in New York state)
- Emissions Controls—California (required at extra cost on all vehicles registered in California)

- Emissions Controls—High-altitude (2.2-liter engine only)
- Engine—2.6-liter Mitsubishi-built (automatic transaxle required at extra cost)
- Engine Cooling—Recommended for vehicles to be equipped with field-installed air conditioning
- Glass—Tinted: all windows
- Lamps—Cornering
- Mats—Floor: front and rear: color-keyed

Mirrors

- Exterior—Dual: power remote control: chrome
- Exterior—Dual: remote control: chrome
- Interior—Passenger visor vanity: illuminated

Power

- Door Locks
- Seat—Bench
- Seat—50/50: left side only
- Windows

Radios

- AM/FM/MX—Electronically tuned digital
- AM/FM/MX—Electronically tuned digital: cassette player with Dolby* sound system
- AM/FM/MX—Manually tuned
- Premium Speaker Package—Electronically tuned radio
- Premium Speaker Package—Manually tuned radio

- Seat—Center armrest bench: vinyl
- Seat—50/50 bench: cloth
- Spare Tire—Conventional
- Speed Control—Automatic (deluxe windshield wipers required)
- Steering Column—Tilt (deluxe windshield wipers required)
- Steering Wheel—Luxury: leather wrapped, two-spoke
- Stripes—Upper body-side and lower deck lid
- Suspension—Sport/handling
- Trunk Dress-Up
- Undercoating
- Wheel Covers—14-inch: wire (four)
- Wheels—14-inch: cast aluminum (four)

- Windshield Wipers—Deluxe: intermittent
- *Dolby is a trademark of Dolby Laboratories.

Optional Packages

Two-Tone Paint Packages

- Sable Brown/Beige Crystal Coat
- Nightwatch Blue/Glacier Blue Crystal Coat
- Black/Bright Silver Crystal Coat

Protection Group

- Lower body vinyl protective coating
- Protective door edge moldings
- Bumper guards, front and rear

Chrysler E Class Sedan

Standard Features

- Alternator—60-ampere
- Armrests—Door
- Ash Receivers—Front and rear
- Battery—370-ampere maintenance-free
- Battery Test Indicator
- Brakes—Power, dual diagonal: disc front; self-adjusting drum rear
- Bumper Rub Strips—Color-keyed
- Bumpers—Energy-absorbing
- Carpeting—Passenger compartment
- Cigarette Lighter
- Cleaner Air System
- Clock—Electronic digital
- Coat Hooks
- Computer—Combustion: electronic
- Console Symbols—International (ISO)
- Coolant Overflow Reservoir
- Corrosion Protection—Extensive use of galvanized steel
- Deck Lid Power Release
- Directional Signals—With lane-change feature
- Door—Fuel filler: with lock and power release
- Door Release Handle—Interior: easy-open with integral rocker type lock/unlock system
- Electronic Ignition and Voltage Regulator
- Electronic Voice Alert System—Audibly announces the following: key in ignition, headlamps on, fasten seat belts, door ajar, low washer fluid, parking brake on, low fuel, low engine oil pressure, engine overheating, electrical system malfunction, all monitored systems OK.
- Head Restraints—Adjustable

- Engine—Four-cylinder 2.2-liter Trans-4
- Engine Cooling Fan—Electric
- Flashers—Hazard warning
- Fuel Filler Cap—Tethered
- Fuel Tank—13-gallon
- Headlamps—Halogen high and low beam: rectangular
- Headliner—Cloth-covered: color keyed
- Heater and Defroster
- Hood—Counterbalanced
- Hood—Insulation pad
- Hood Ornament—Pentastar
- Hood Release—Inside
- Horn—Pass/flash system
- Horns—Dual
- Instrument Panel—Brushed finish cluster with two-tone woodtone treatment
- Instrument Panel—Message center: includes low washer fluid, low fuel, trunk ajar, door ajar
- Instrument Panel—Padded
- Insulation—Special: body sound
- Lights—Ash receiver, dome/reading, glove box, ignition switch (with time delay), door-actuated dome-light, parking brake warning, side marker with reflectors, trunk, underhood
- Lock—Glove box
- Mirrors—Inside rearview day/night
- Mirrors—Outside dual manual: chrome
- Moldings—Bright backlight, windshield, belt, upper door frame, quarter window, drip rail, lower deck lid
- Radio—AM: manually tuned
- Steering—Rack-and-pinion: power
- Steering Wheel—Corporate luxury
- Suspension—Front: Iso-Strut with coil springs around the shock absorbers, linkless sway bar; rear: flex arm beam axle with trailing link coil springs and premium shock absorbers
- Taillamps—Full width
- Tire—Spare: compact, high-pressure
- Tires—P185/70R14 steel-belted radial wide white sidewall
- Transaxle—Three-speed automatic
- Ventilation System—Upper level forced air: four outlets
- Wheel Covers—Luxury (set of four)
- Windshield Wipers and Washers—Two-speed: electric
- Wiper System—Concealed

Interior Trim

Standard Chrysler E Class Interior—Cloth center armrest bench seat with adjustable head restraints and cloth-covered door trim panels. Available in Blue, Silver, Red, and Beige.

Optional Chrysler E Class Interior—All-vinyl center armrest bench seat with adjustable head restraints. Offered in Silver, Red, and Beige.

Optional Chrysler E Class Interior—50/50 cloth bench seat with dual armrests, dual recliners, seat-mounted center console with seat controls, and seatback storage pockets. Door trim panels are the same as standard interior. Available in Blue, Silver, Red, Beige, and Brown.



**STEWART M. DUHIG
OF ED BARWICK
CHRYSLER - PLYMOUTH
VOLVO -
PH. 224-3166 - ASK FOR DUKE**

E Class Exterior Colors



Charcoal Metallic



Nightwatch Blue



Glacier Blue Crystal Coat



Black



Bright Silver Crystal Coat



Beige Crystal Coat



Crimson Red



Sable Brown



Pearl White

Two-Tone Packages



Black/Bright Silver Crystal Coat



Sable Brown/Beige Crystal Coat



Nightwatch Blue/Glacier Blue Crystal Coat

Note: Due to occasional printing irregularities, the colors shown may vary slightly from actual hues. See your Chrysler dealer for accurate color chips.

All product illustrations and specifications are based on authorized information. Although descriptions are believed correct at publication approval, accuracy cannot be guaranteed. Chrysler Corporation reserves the right to make changes from time to

Form No. 81-005-3019 8/82 (175M) Litho in U.S.A.

Chrysler for 1983

LeBaron.
Like no other car built in America, Europe, or Japan.



Cordoba.
America's road-ready, value-packed midsize specialty car.



New Yorker Fifth Avenue Edition.
The best luxury car value in America.



Optional 5/50 Protection Plan Coverage

Chrysler Corporation offers a 5/50 "Added Coverage" Service Contract for your new Chrysler E Class which provides protection against rising service and parts costs for specified major repairs not included in the 5/50 limited warranty. Coverage starts on the specified components in the plan after your vehicle's "basic" 12-

month/12,000-mile limited warranty expires on these components and continues for five years or 50,000 miles (whichever occurs first) from the vehicle's original warranty start date. A deductible applies. The plan provides an allowance for alternate transportation and towing. Ask your dealer for details.

Dimensions, Weight and Capacity

| | | | |
|-------------------|--------|-----------------------|-------------|
| Length: | 185.6" | Curb Weight: | 2,583 lbs |
| Width: | 68.3" | Tread (front/rear): | 57.6"/57.0" |
| Height: | 52.9" | Cargo Capacity (est): | 17.0 cu ft |
| Wheelbase: | 103.1" | Passenger Capacity: | 6 |
| Turning Diameter: | 35'6" | Fuel Capacity: | 13 gal |

Engines and Transaxles

| Type | Displacement | Bore & Stroke | Compression Ratio | Horsepower | Torque | Transaxle Availability |
|--------------------|----------------------|---------------|-------------------|----------------|-------------------|--------------------------|
| | | | | SAE Net at RPM | | |
| Federal/California | 2.2-liter (135 CID) | 3.44 x 3.62 | 9.01:1 | 94 hp @ 4,800 | 117 lb-ft @ 2,800 | S-Automatic (2.78 OTGR)† |
| Federal/California | 2.6-liter* (156 CID) | 3.59 x 3.86 | 8.2:1 | 92 hp @ 4,500 | 131 lb-ft @ 2,500 | S-Automatic (3.02 OTGR)† |

*Mitsubishi-built.

†OTGR: overall top gear ratio.

time, without notice or obligation, in prices, specifications, colors and materials, and to change or discontinue models. See your dealer for the latest information.

Standard Safety Features

- Safety-Rim wheels
- Combination lap-shoulder belts for the driver and right front passenger, and lap belts for all other passengers
- Seat belt reminder system
- Energy-absorbing steering wheel
- Dual braking system with separate braking fluid reservoirs in the master cylinder
- Brake fluid pressure loss warning light (also serves as indicator when parking brake is applied)
- Hazard warning flasher system
- Turn signals with lane-change feature
- Electronic ignition
- Backup lights
- Energy-absorbing sun visors
- Front seat head restraints
- Energy-absorbing front seatbacks
- Inside and outside rearview mirrors
- Side marker lights and reflectors
- Seatback latches on folding seats
- Fade-resistant front disc brakes
- Electric windshield washers and wipers
- Ignition and steering column lock
- Anti-theft trunk lock
- Headlamp and wiper circuit breakers with automatic reset
- Key-left-in-ignition warning
- Non-override door locks (except driver's door)
- Resilient window crank knobs
- Side door beams
- Dual throttle return springs
- Interlocking door latches
- Recessed inside door release handles
- Rotary glove box latch
- Reinforced windshield header and roof
- Glare reduction measures for windshield wipers, instrument panel, and steering wheel
- Double ball-joint rearview mirror mount

Buy or Lease a Chrysler E Class

In these days of tight money and high interest rates more consumers are considering leasing as an alternative to buying. Leasing a new Chrysler E Class usually eliminates large down payments, and often results in lower monthly payments because you're paying only for that portion of the car life under the leasing agreement.

Leasing could be right for you, and the more you learn about it the more likely you are to consider it seriously. If leasing sounds like a sensible solution to your transportation needs, talk it over with us—your leasing professionals.

MOPAR parts are engineered by Chrysler Corporation for use in your Chrysler E Class. When replacement is necessary, be sure to specify MOPAR parts. Used by professional mechanics all over the world.

**STEWART M. DUHIG
OF ED BARWICK
CHRYSLER - PLYMOUTH
VOLVO -**

PH. 224-3166 - ASK FOR DUKE



A PRODUCT OF
THE NEW CHRYSLER
CORPORATION