



DODGE

1 9 9 3

P I C K U P



RAM PICKUP
DAKOTA
RAMCHARGER
RAM 50

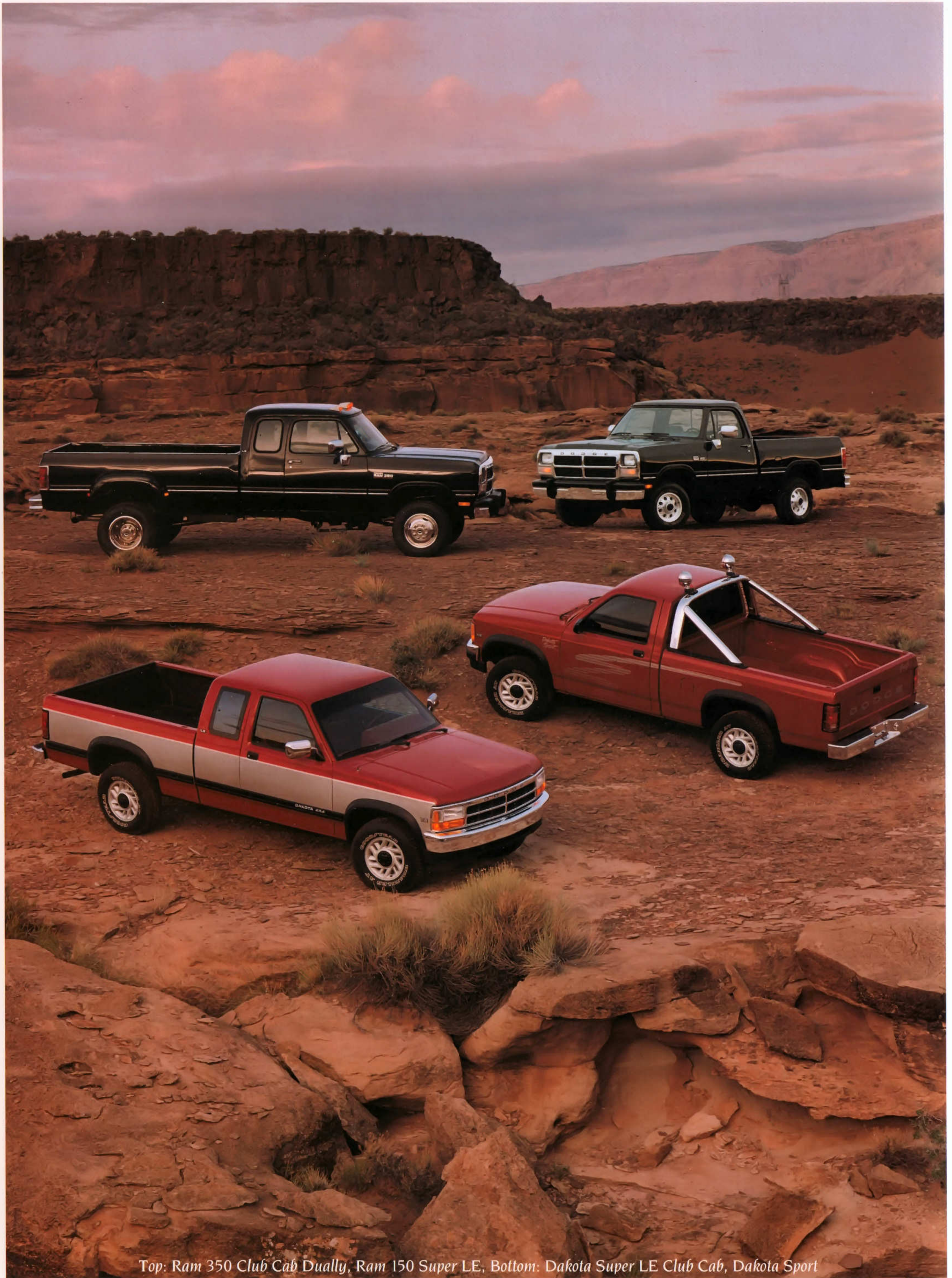

Top: Ram 350 Club Cab Dually, Ram 150 Super LE, Bottom: Dakota Super LE Club Cab, Dakota Sport



(top left)
5.9-liter I-6 Cummins Intercooled Turbo Diesel
 • 160 horsepower at 2,500 rpm.
 • 400 pound-feet of torque at 1,700 rpm.

(top right)
New MAGNUM 5.9-liter V8
 • 230 horsepower at 4,000 rpm.
 • 325 pound-feet of torque at 3,200 rpm, Light-Duty Cycle.
 • 330 pound-feet of torque at 2,800 rpm, Heavy-Duty Cycle.



(bottom left)
MAGNUM 5.2-liter V8
 • 230 horsepower at 4,800 rpm.
 • 280 pound-feet of torque at 3,200 rpm.

(bottom right)
MAGNUM 3.9-liter V6
 • 180 horsepower at 4,800 rpm.
 • Dakota: 225 pound-feet of torque at 3,200 rpm.
 • Ram Pickup: 220 pound-feet of torque at 3,200 rpm.

Keep America powerful.

A new MAGNUM 5.9-liter V8 joins the successful family of MAGNUM Series engines for a choice of power you can

only get from Dodge. Each of these state-of-the-art MAGNUM engines is the most powerful in its class and

is designed for heavy-duty use, long life and minimum maintenance. In just one year, Dodge MAGNUM engines

have provided over 1.7 billion miles of work and recreational power for demanding truck owners across America.

Ram-Tough Trucks

Today's Dodge trucks, gas and diesel, can overpower any other line of pickups you can buy.* As you read through this catalog, you'll see how Dodge backs up this statement with Ram-tough engineering and durability features that add up to the Dodge advantage for you every day.

Dodge trucks are built to take the punishment dished out by big jobs, bad roads, no roads, long hauls, lousy weather, stop-and-go traffic and the daily grind. Name your nightmare. These trucks are designed to get you through it and do your job with unbeaten reliability.

Only Dodge combines proven, job-rated toughness with the best-in-class horsepower of the MAGNUM 3.9-liter V6 or the MAGNUM 5.2-liter V8 offered on Ram Pickups, Dakotas and Ramchargers—plus the newest state-of-the-art MAGNUM

Series engine: a potent 5.9-liter V8 available on Ram Pickups and Ramchargers.

Only Dodge offers you the awesome, unmatched towing power and efficiency of the Cummins Intercooled Turbo Diesel engine: 400 pound-feet of torque at 1,700 rpm—a world-class advantage available on Ram 250/350 Pickups.

And whether they're empty or loaded to the max, Dodge trucks have the responsive handling, controlled ride and sure braking you need to drive every mile with confidence.

In all-important warranty protection, Dodge trucks are ahead of the pack with the best coverage in the industry: the limited warranties of Chrysler Corporation's exclusive Owner's Choice Protection Plan.†

The 1993 lineup of Ram-tough Dodge trucks leads the way in keeping you and America powerful... as a test-drive will quickly prove.



CONTENTS

Dodge Ram Pickup.....	Page 8	Trailer Towing, Engine	
Dodge Dakota Pickup.....	Page 20	Lineup.....	Pages 44, 45
Dodge Ramcharger.....	Page 34	<i>*Certified by SCORE International.</i>	
Dodge Ram 50 Pickup.....	Page 40	<i>†See page 43 and your dealer for details on these limited warranties.</i>	
Warranty.....	Page 43		



Ram 150 Super LE 4x4



Dakota Super LE Club Cab 4x4



Ramcharger Canyon Sport



Ram 50 SE

No one builds a tougher, safer truck than Dodge.

Ram-tough Dodge trucks are built on the brute strength of carbon steel frames with a maximum load strength of 36,000 pounds per square inch.

For a confident ride and responsive handling, an indepen-

dent front wishbone-type suspension is standard on all two-wheel-drive Dodge pickups and Ramchargers. Torsion bar suspension on four-wheel-drive Dakota and Power Ram 50 models absorbs the shocks of rough terrain for solid straight-ahead steering control. And for brute strength and superior ground clearance, Ram Pickups and Ramcharger 4x4s feature solid live front axles.

Gas-charged front/rear shock absorbers and computer-selected springs optimize the ride and handling on Ram Pickups, Dakotas and Ramchargers, while providing a long life of hauling and towing. The precise control of rack-and-pinion steering is standard on two-wheel-drive Dakotas.

Engineered for safety, Dodge trucks come with dual hydraulic

brake lines, energy-absorbing steering columns, adjustable bench seat headrests, flash-to-pass turn signals, a Unibelt restraint system, safety-rim wheels, a full set of easy-to-read gauges, plastic fuel tanks and many other safety features.

A computer-controlled rear-wheel antilock brake system is standard on Ram Pickups, Dakotas, Ramchargers and—new for '93—on Ram 50s and Power Ram 50s. A new four-wheel antilock brake system is also available on Dakotas.

Beefy MAGNUM power trains include state-of-the-art MAGNUM engines backed up with heavy-duty prop shafts, U-joints, axles, and differential gears.

A five-speed manual transmission with overdrive is standard on Dakotas equipped



Dakota can carry four-by-eight-foot sheets of building material in an available eight-foot cargo box with the tailgate closed.

with the 2.5-liter engine—the same transmission used on Dakotas equipped with the MAGNUM 3.9-liter V6. Special lubrication to the fifth gear, gear bushing and other key areas helps give this transmission Ram-tough reliability at high speeds.

A heavy-duty five-speed manual transmission with overdrive is standard on Ram Pickups, and a high-capacity Getrag five-speed manual transmission with overdrive is standard on diesel-powered Ram Pickups.

(Below right) Rod Hall storms to another Baja victory in his 800-horsepower Class Four Dodge Power Ram 150.

All Dodge trucks feature galvanized steel to help prevent corrosion in the floor pan, wheelhousings, underbody, front fenders and other critical areas.

Double-wall construction is featured for full-size toughness on pickup cargo box sides, tailgate, front fenders and other areas.

Four-by-eight-foot sheets can be carried flat on the floor between the wheel wells of a Ram Pickup. The all-welded cargo box on every Ram-tough Dodge Pickup is free of exposed bolts—like those used on Ford pickups—that can trap water and cause rust.



8-foot cargo box is available on Ram Pickup (shown) and Dakota. 6 1/2-foot cargo box is available on Ram Pickup (shown) and Dakota.



Walker Evans races this Ram 150 in SCORE/HDRA desert events and a Dakota in stadiums.

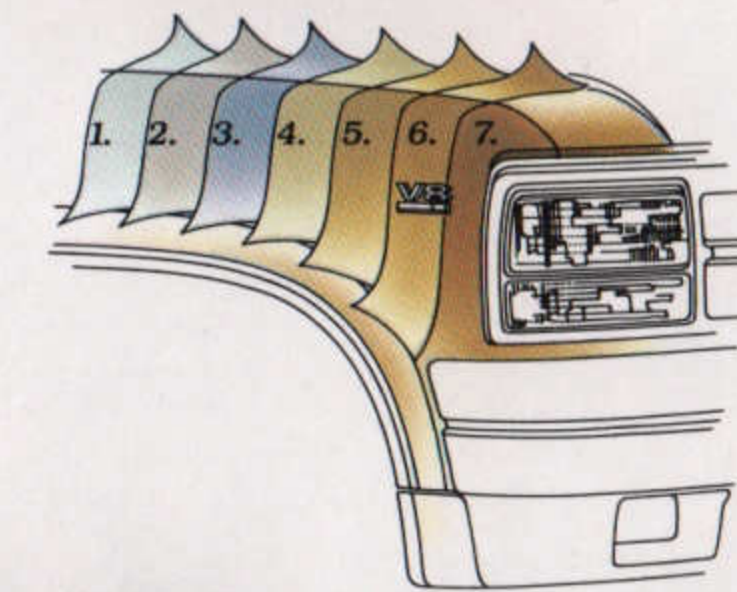

1. Extensive use of galvanized steel
2. Spray cleaning and phosphate treatment
3. Uniprime (TM) primer coat
4. Lower bodyside anti-chip urethane coating
5. Enamel paint—First coat
6. Enamel paint—Second coat
7. Clear Coat finish

A new four-wheel antilock brake system is optional on 1993 Dakotas for added braking control.

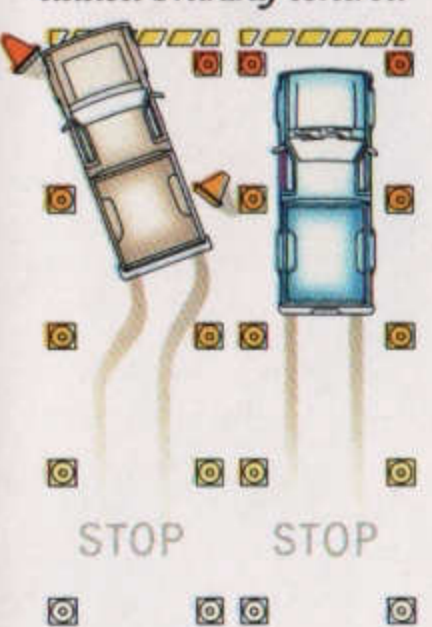

A heavy-duty four-speed automatic transmission with overdrive is optional on all MAGNUM-powered models. This Ram-tough power handler has a lockup torque converter to eliminate slippage—resulting in lower transmission temperatures, less engine wear and improved fuel economy.

Dodge 4x4 sets the industry standard. Ram-Trac lets you shift-on-the-fly from two- to four-wheel drive and back without stopping or backing up. Standard on Dodge Power Ram 150/250 Pickups, Dakotas and Ramcharger models. For heavy-duty off-road jobs, Dodge Ram 250/350 Pickups offer the New Process Model 205 cast-iron transfer case featuring gear drive and manual locking hubs (used on all diesels).

Proven off-road tough in SCORE/HDRA Desert Racing, race-modified Dodge Ram Pickups have won nine championships over the last 11 years. Last season in a Dodge Power Ram 150, Rod Hall added to his legend as the winningest driver at Baja by scoring his twelfth major Baja victory.

Midsize Dakota has a smooth-riding independent front suspension and a bigger frame than any compact pickup for more hauling and towing capacity.

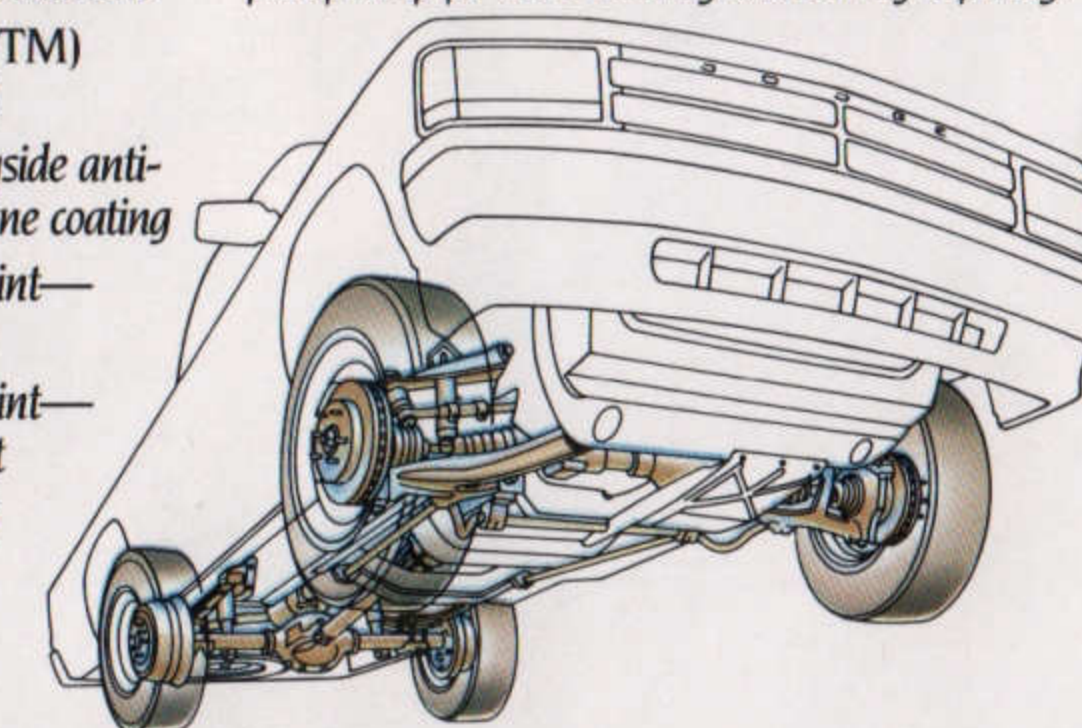

And in "chunk-of-Baja" stadium racing, Walker Evans is defending the Grand National Sport Truck Championship and Manufacturers' Cup Challenge titles he won with a modified Dakota 4x4.

Extensive corrosion protection is standard on every Dodge truck. As part of the seven-step process shown at the upper left, Dodge Ram Pickups, Dakotas and Ramchargers get a lower bodyside antichip urethane coating and a Clear Coat paint finish; Dakota frames are also dipped in hot wax.

Dodge Ram 50

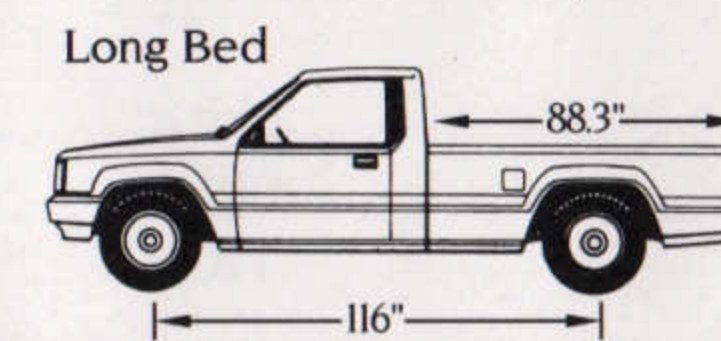
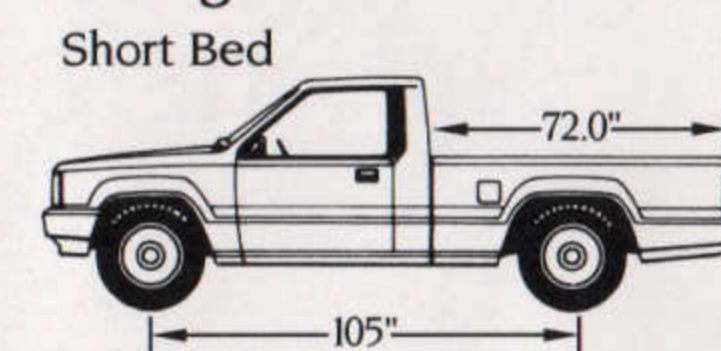

Dodge Dakota

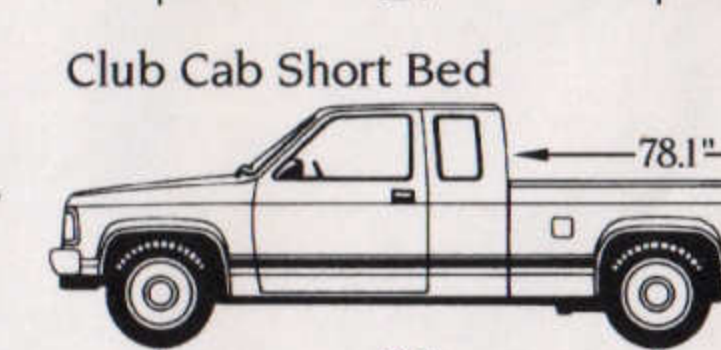
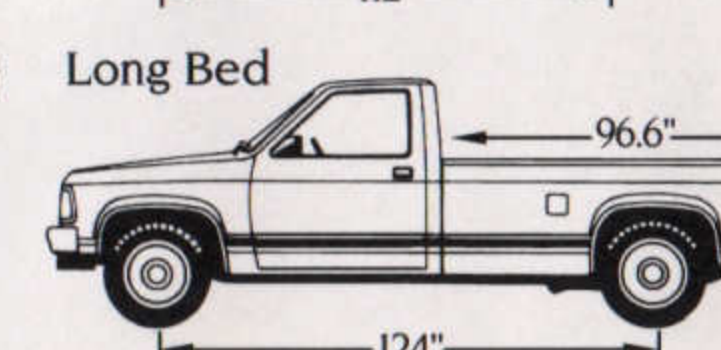
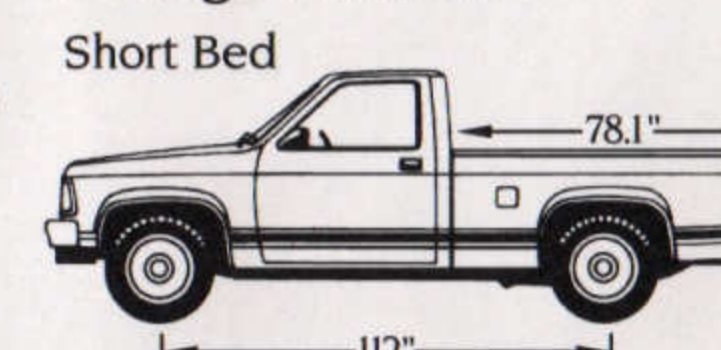

Dodge Ram Pickup

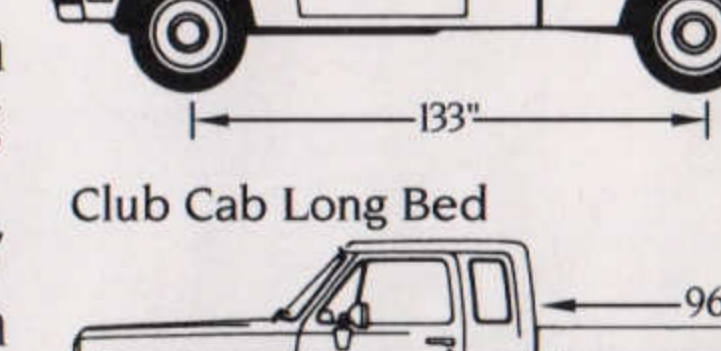
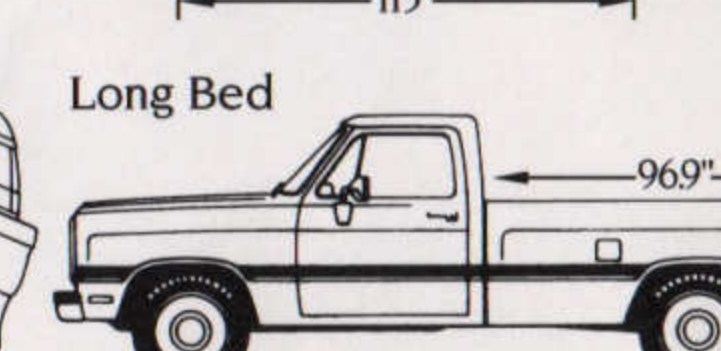
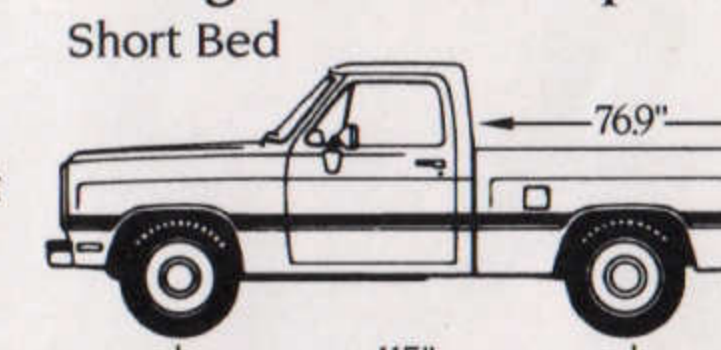

And Chrysler Corporation's Owner's Choice Protection Plan protects every Dodge vehicle with an unmatched choice in limited warranties. See page 43 and your dealer for details.

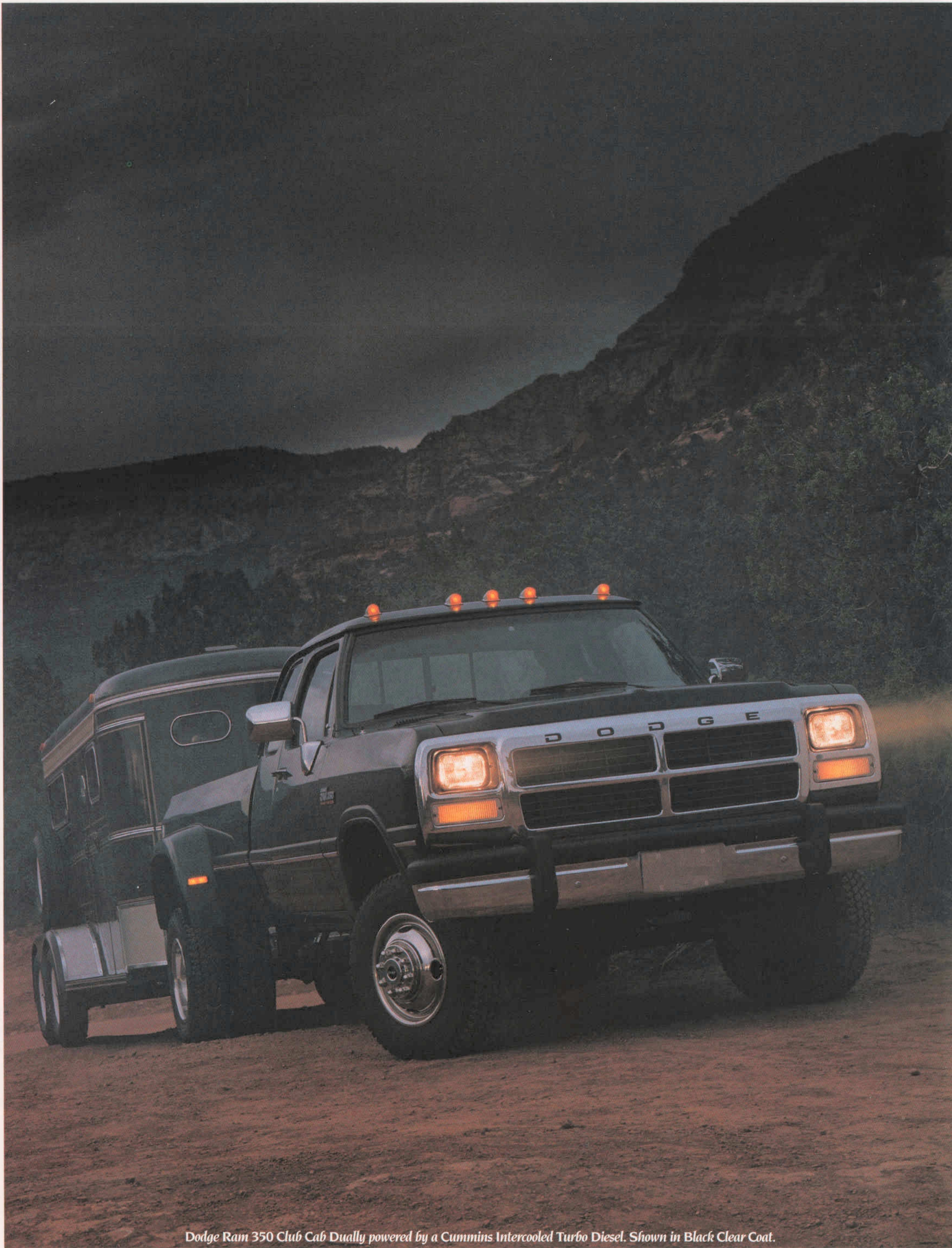

Dodge Ram 350 Club Cab Dually powered by a Cummins Intercooled Turbo Diesel. Shown in Black Clear Coat.



"Tow Vehicle of the Year."

-Trailer Boats*

The most powerful lineup of full-size pickups in America offers you 15 Ram-tough models to meet your needs with an unmatched choice of state-of-the-art gas and diesel engines. A potent new MAGNUM

5.9-liter V8 is offered on all Ram models, and joins the MAGNUM Series 3.9-liter V6 and 5.2-liter V8 gas engines for a full lineup of best-in-class hauling and towing power that the competition doesn't offer.

The 5.9-liter Cummins Intercooled Turbo Diesel engine, available on Ram 250/350 Pickup models, pumps out the most torque of any diesel pickup engine: 400 pound-feet at 1,700 rpm.

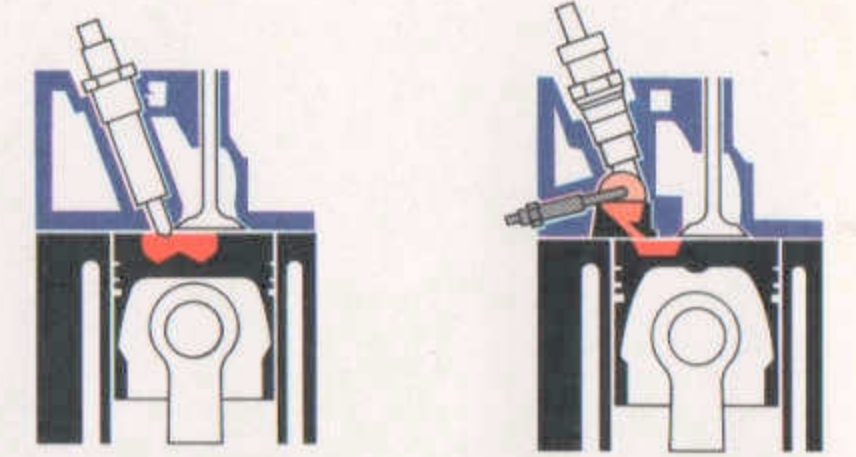

Cummins direct-chamber injection.

Ford/Chevy/GMC indirect injection.

Open direct-chamber fuel injection provides smooth, efficient combustion without the complexity of a swirl prechamber and glow plugs which can burn out or swell up.

Engineered from the ground up for the long haul, the Cummins Intercooled Turbo Diesel is the only pickup diesel that is both turbocharged AND intercooled. Plus, it has the most big-rig features in its class, like direct injection shown above, and:

- A proven turbocharger made by Holset (a Cummins subsidiary) for high-mileage reliability.
- Seven main bearings for long-haul durability.



Connecting rods: Dodge Cummins Intercooled Turbo Diesel, Ford Navistar Diesel, Chevy/GMC Detroit Diesel.

- Gear-driven components to eliminate chains that can break.
- Largest forged crankshaft (150 pounds) and connecting rods in its class for brute strength and long life.
- Design simplicity that requires no special maintenance tools.
- Heater grid to warm intake air for fast starts.

"...for overall performance, the Cummins engine in the Dodge (350 Club Cab Dually) stood out—especially in fuel economy."

-Trailer Boats

Cummins 5.9-liter Intercooled Turbo Diesel

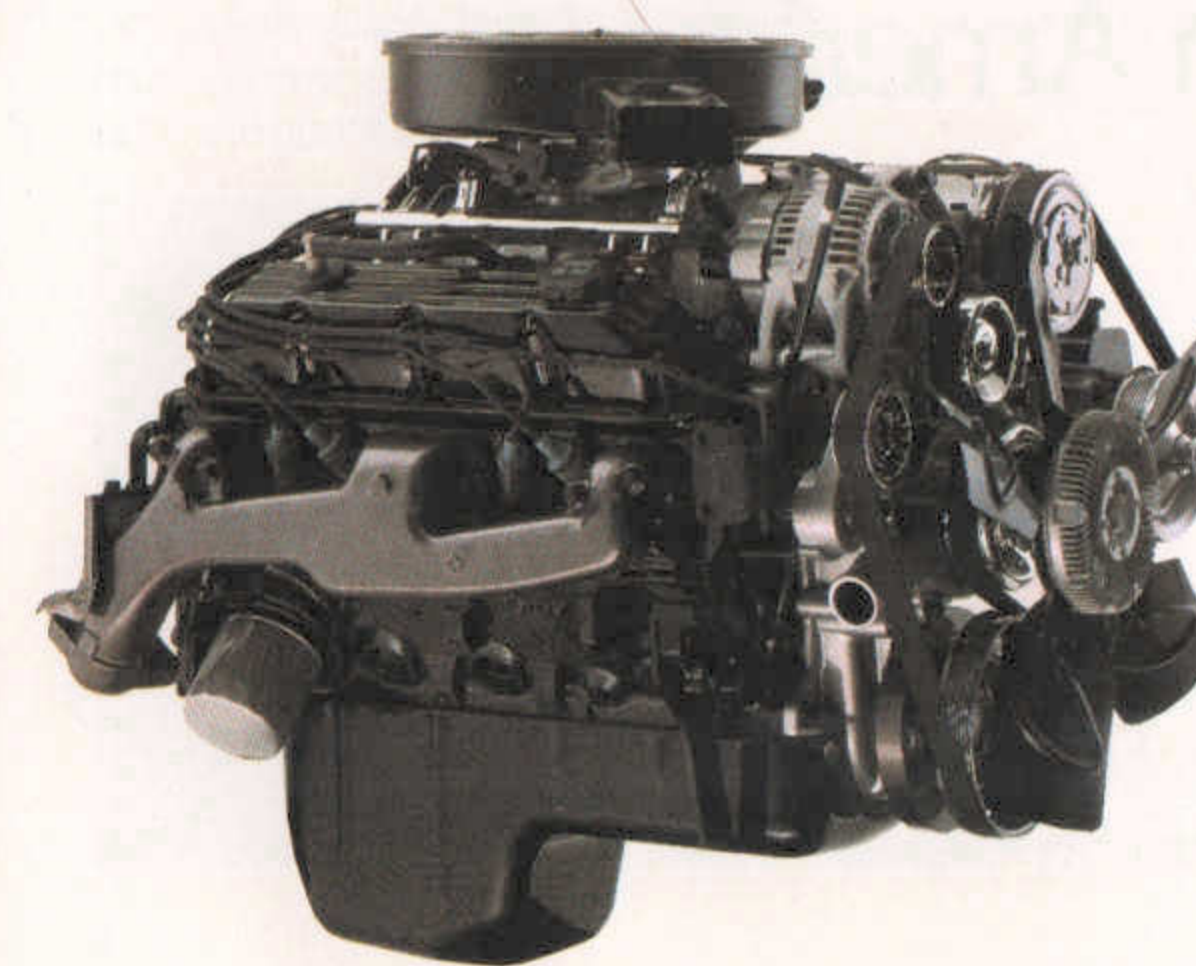
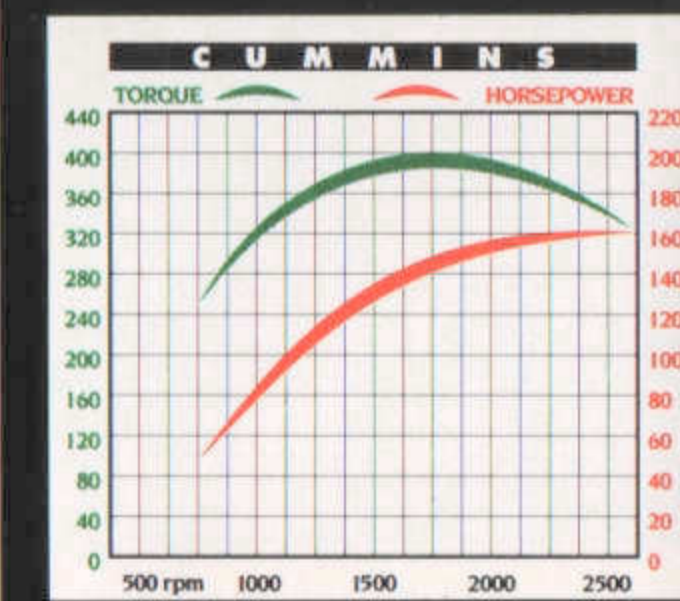
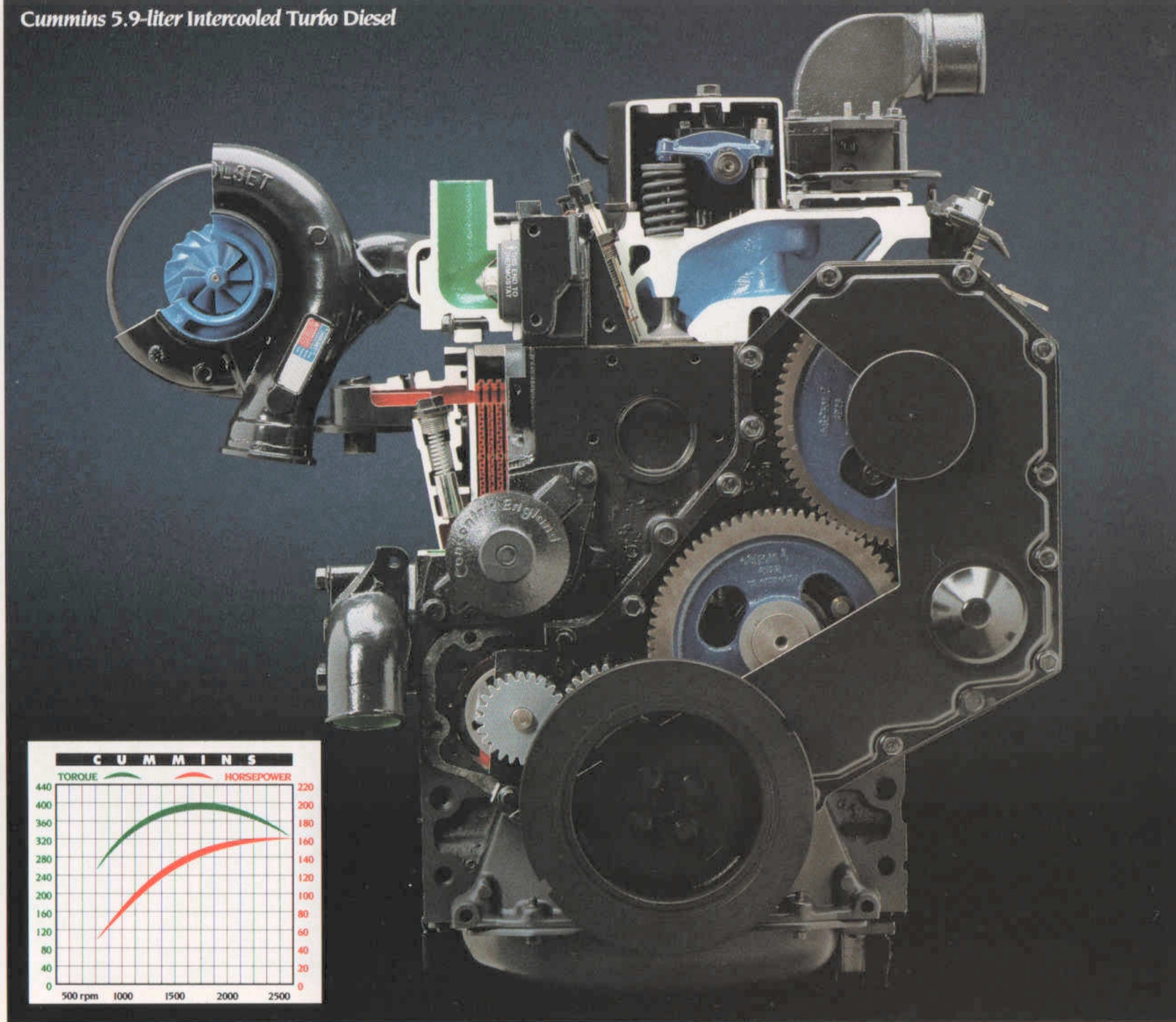

New MAGNUM 5.9-liter V8 with 230 horsepower at 4,000 rpm and 325 pound-feet of torque at 3,200 rpm, Light-Duty Cycle or 330 pound-feet of torque at 2,800 rpm, Heavy-Duty Cycle.

- New sequential multipoint fuel injection (SMPI) boosts horsepower and fuel economy.
- New tuned intake manifold, intake/exhaust valves and high-flow exhaust manifold for improved breathing and more horsepower.
- New combustion chambers, ports, pistons and ring package for more horsepower and improved emissions control.
- New progressive-bore throttle body (patented by Dodge) for better engine response and more horsepower.
- New self-tensioning serpentine belt accessory drive for less maintenance and reduced engine vibration.
- Improvements in the head, block and oil pan for less weight, tighter sealing and longer life.
- 29-percent fewer components than last year for improved reliability, reduced weight and less maintenance.

*Dodge Ram 350 Club Cab Dually with a Cummins Intercooled Turbo Diesel engine.

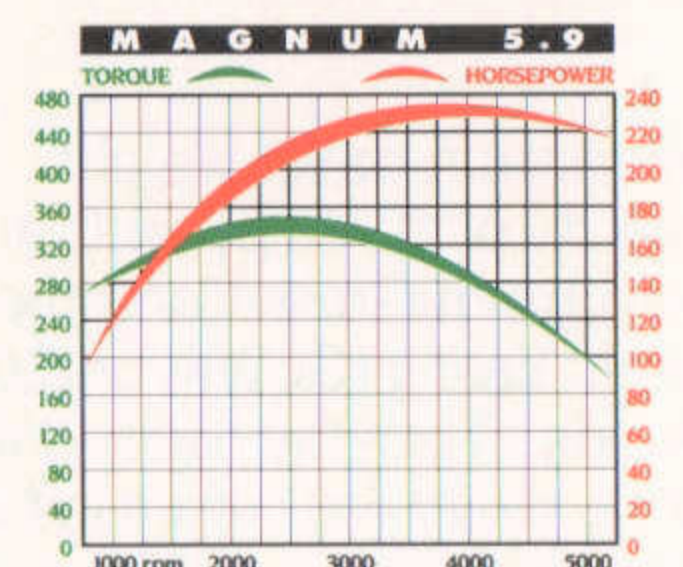



The hardest-working pickup in America.

A maximum trailer weight capacity of 11,700 pounds and a maximum Gross Combined Weight Rating (GCWR) of 17,000 pounds. That's the heavy-duty towing ability you command in a Ram 350 Dual-Rear-Wheel Regular Cab Pickup (Dually)

when it's properly equipped with an available Cummins Intercooled Turbo Diesel engine, standard manual five-speed transmission and available 4.10 axle ratio.

This coast-to-coast towing muscle is made possible by the same Cummins diesel technology

that powers over 50 percent of today's big on-highway Class 8 trucks, including the heavy-duty 18-wheelers. And it's proven every day in over 125,000 Cummins-powered Ram Pickups that do America's big pickup jobs.

The big-rig guts in a Cummins-

powered Ram Pickup include as standard: • Five-speed manual Getrag transmission • 13-inch clutch • Heavy-duty Dana 70 rear axle • 120-amp alternator • 1,025-amp battery • NP-205 cast iron gear-drive transfer case on 4x4 models

Mopar accessories offer you additional ways to customize your Ram Pickup with a wide range of recreational and job-ready dealer-installed options, such as grille guards, trailer hitches, running boards, chrome wheel liners, snowplows and much more. See your dealer for the complete list.



- Heavy-duty engine cooling
- Auxiliary oil cooling on automatic transmissions • Heavy-duty frame rails • Upgraded springs and shocks.

A new super-duty transmission oil cooler is also available as a dealer-installed option for Cummins-equipped Ram Pickups with automatic transmissions and the standard 3.54 axle ratio. The new transmission oil cooler adds an extra 2,000 pounds to the maximum Gross

Combination Weight and Trailer Weight Ratings.

Put Cummins torque to work for you in a wide choice of Ram Pickup 250/350 models: regular or Club Cab; two- or four-wheel drive; single- or dual-rear wheels. You'll agree with towing experts who've said:

"...it's still the best tow vehicle we've found...especially with this engine."

-Trailer Boats

Dodge Ram 350 Super LE Club Cab Dually with Cummins Intercooled Turbo Diesel power. Shown in Black Clear Coat.



No one builds a tougher truck than Dodge.

Big MAGNUM-powered Ram Pickups take on seemingly impossible jobs with standard Ram-tough components like:

- Carbon steel frames
- Heavy-duty transmissions
- Rear wheel antilock brakes
- Heavy-duty front and rear axles
- Solid front axle on 4x4 models

- Heavy-duty batteries
- Available rear step bumpers
- Rated to tow 5,000 pounds
- Self-spring hoods with fully stamped inner panel
- Steel tailgate straps and more.

Dodge makes sure every Ram Pickup is specified to more than meet your needs with a combi-

nation of Ram-tough standard equipment and available Customer-PreferredSM Advantage Packages.

Adding one of these Customer-PreferredSM Advantage Packages provides a combination of MAGNUM power and versatility you won't get from Ford or Chevy:

- **Work Advantage**—adds popular equipment like payload and tire upgrades, rear step bumper, 30-gallon fuel tank and other items to help you do the toughest jobs.

- **Work Special**—adds comfort and appearance items such as styled steel wheels,

bodyside protective moldings, deluxe cloth seat, carpeting and more, for a truck that looks good and works hard, too.

- **Super LE**—our top-of-the-line truck, featuring premium interior comfort and convenience items that include air conditioning, power windows, power locks,

power mirrors, speed control, tilt steering, cassette stereo radio and much more.

"...a wide range of configurations... the (Cummins) power available is more than enough to pull a house trailer. Or a house."

-Road & Track Truck & Van Buyer's Guide

Bedliners, bedmats, tailgate protector, rear tube bumpers and many other Mopar accessories are available as dealer-installed options.



Cummins-powered Ram 250 Super LE 4x4. Shown in Bright White Clear Coat.



“Versatile taskmasters for the long haul.”

-Road & Track Truck & Van Buyer's Guide

MAGNUM power tool. Towmobile. Loyal worker. Weekend escape machine. Whatever your needs are in a full-size pickup, there's a Ram Pickup to meet them with hundreds of combinations possible from a choice of:

- Short and long wheelbase models
- Regular Cabs
- Club Cabs with an extra 34 cubic feet of cab room
- Single- or dual-rear-wheel models
- Two- or four-wheel drive
- Payloads from 1,660 to 5,400 pounds
- Gross Vehicle Weight Ratings up to 10,100 pounds

- Gross Combination Weight Ratings (truck and trailer) up to 17,000 pounds
- MAGNUM V6, V8 or Cummins Intercooled Turbo Diesel power... and more.

In addition, Customer-PreferredSM Advantage Packages let you add valuable equipment

while saving money with big discounts equal to NO CHARGE* for some of the equipment. The Super LE Package, for example, includes a MAGNUM V8, automatic transmission, air conditioning and more at NO CHARGE.* Ask your salesperson to

Ram 150 Work Special 4x2. Shown in Flame Red Clear Coat.



help you choose and equip a Ram Pickup for work, recreation or both. And for information on Ram Chassis Cabs and other heavy-duty commercial applications, ask for a free copy of the 1993 Dodge Work Truck Catalog.

*Package savings based on equipment if purchased separately.

Ram 150 4x2 Work Special Long Bed. Shown in Flame Red Clear Coat. Power Ram 150 4x4 Super LE Short Bed. Shown in Black Clear Coat.

“Most of all, the Rams are well-suited to any task potential owners are likely to set for them.”

-Road & Track Truck & Van Buyer's Guide

Full-size comfort and convenience.

A Ram Pickup cab has the generous room you expect from a full-size pickup: the hip, leg, head and shoulder room you need to really feel comfortable. So much room, for example, that you get almost three inches more hip room in a Ram Pickup than in any comparable Ford F-Series model.

Dodge adds convenience to this comfort for versatility that means as much on a job site as on a long-distance vacation. Power-assisted steering and power-assisted brakes are standard, as are a full complement of gauges. The heater, radio and optional air conditioning controls are easy to reach and use; the open design of the steering wheel



spokes provides an unrestricted view of the speedometer and gauges; and the control buttons for optional speed control are handily mounted on the wheel for instant use. You'll find attention to detail like this throughout a Ram Pickup cab to help you fight fatigue on long trips.

For the ultimate in convenience, choose optional power windows, power door locks, power mirrors and tilt steering column. They're all included in the top-of-the-line Super LE, but you can choose them elsewhere as well.

All seating is first class.

Whether you prefer heavy-duty vinyl or premium cloth, Dodge Ram Pickup seats are designed for a "command-of-the-road" seating position. A full foam-cushioned bench seat is standard on regular cab models, and Club Cab models come with a split-bench seat and rear side-facing jump seats; high-back reclining front bucket seats with a center storage console are available.

For all-weather comfort, Ram Pickups come with tinted glass

Easy-to-read analog gauges are featured on all Ram Pickups: 100-mph speedometer, odometer, trip odometer and voltmeter—plus engine coolant temperature, engine oil pressure and fuel level gauges. The Super LE instrument panel shown includes woodgrain applique, cassette stereo radio, speed control, tilt steering and more.

and excellent flow-through ventilation from front-door pivoting vent windows, door air exhausters and a driver-side Ram-air floor vent. Rear quarter vent windows are standard on Club Cab models; a sliding rear window is available on all models.

"...quite comfortable. That's especially true of the Club Cab versions..."

-Road & Track Truck & Van Buyer's Guide

Ram Club Cab LE interior, shown in Spice. The available premium cloth and vinyl bucket seats are safety-engineered with integrated head restraints and are human-engineered with generous lumbar and thigh support, plus recliners. A large storage console between the seats includes a two-place cup holder for beverages.



Ram Pickup Selected Standard and Optional Equipment

Super LE	Work Special (150 Regular Cab only)	Work Advantage	Base
Air Conditioning	O	O	O
Alternator—75-amp	S	S	S
—120-amp (standard with Cummins Diesel)	O	O	O
Axle—Sure Grip Differential	O	O	O
Battery—600-amp maintenance-free	S	S	S
—810-amp maintenance-free	O	O	O
—1,025-amp maintenance-free	S ⁽¹⁾	S ⁽¹⁾	S ⁽¹⁾
Brakes—Power front disc/rear drum with rear-wheel antilock	S	S	S
Bumper, Front—Bright	S	S	S
—Bright with black step pad/bumper guards			●
Bumper, Rear—Argent painted	O	●	●
—Bright with step pad	O	O	●
Cigar Lighter	S	S	S
Clutch—Hydraulic actuation (11" diameter gas, 13" diesel)	S	S	S
Cooler—Automatic transmission auxiliary oil	O	● ⁽²⁾	O
—Super duty automatic transmission oil cooler for diesel engine only—requires 3.54 axle ratio. Dealer installed—adds 2,000 lbs to trailer weight and G.C.W.R. for trailer towing	O	O	O
Cooling—Maximum engine	O	● ⁽²⁾	O
Door Trim—Full-length vinyl with armrest	S	S	S
—Full-length premium cloth with armrest and lower carpet			●
Floor Covering—Heavy-duty black rubber mat	S	S	
—Premium carpeting			●
Frame—36,000 psi high-strength carbon steel ladder type	S	S	S
Fuel Tank—22-gallon	S		
—30-gallon (standard on Club Cab)	O	●	●
Gauges—Analog type: includes 100-mph speedometer, engine temperature, fuel, oil pressure, voltmeter and trip odometer	S	S	S
Glass—Tinted, all windows with door vent windows	S	S	S
—Sliding rear window	O	O	●
Grille—Bright	S	S	S
Halogen Headlights			●
Hood Release—Inside	S	S	S
Heater, Engine Block	O	O	O
Lights—Cab clearance (standard with dual-rear wheels)	O	O	O
Light Group—Interior upgrade including cargo bed light	O	O	●
Mirrors—6"x9" dual bright, manual	O	●	●
—6"x9" dual bright power, remote	O	O	●
—7"x10" dual bright, wide mounted	O	O	O
Moldings—Lower bodyside and wheel flare	O	O	●
Paint—Premium exterior paint with Clear Coat finish and lower body antichip coating	S	S	S
—Two-tone paint treatment, lower bodyside	O	O	O
—Two-tone paint treatment, center band	O	O	O
Pickup Box—Double wall construction with stake pockets and high-strength steel floor	S	S	S
Power Windows and Door Locks	O	O	●

Super LE	Work Special (150 Regular Cab only)	Work Advantage	Base
Radio—AM/FM stereo with clock (two speakers)	S	S	S
—AM/FM stereo with cassette and clock (four speakers)	O	O	●
—Premium AM/FM stereo, with cassette and clock (four speakers), seek-and-scan, Graphic Equalizer			O
Seats—Heavy-duty three-man vinyl bench (split-back on Club Cab)	S	S	
—Deluxe cloth three-man bench (split-back on Club Cab)	O	O	●
—Premium cloth three-man bench (split-back on Club Cab)			●
—Premium cloth reclining buckets with center storage console (Club Cab)	O	O	O
—Club Cab rear: Two side-facing fold-up seats	S	S	S
Shock Absorbers—Gas-charged, long-life (heavy-duty on 250, 350)	S	S	S
Skid Plate—4x4 transfer case, protective (Standard on Diesel)	O	O	O
Snowplow Preparation Group (4x4 150, 250)	O	O	O
Snowplow Preparation Group, Heavy-Duty (4x4 250, 350)	O	O	O
Speed Control and Tilt Steering Group	O	O	●
Stabilizer Bar—Front	O	O	O
Steering—Power-assisted recirculating ball-type	S	S	S
Storage Tray—Behind seat on regular cabs			●
Suspension—Front independent coil spring (4x2)	S	S	S
—Front solid live axle leaf spring (4x4)	S	S	S
Tailgate—Removeable with caliper lock latches and steel strap holds	S	S	S
—Premium brushed aluminum applique			●
Tilt Steering Column (without Speed Control)	O	O	O
Tires—P235/75R15 BSW all-season steel radial	O	● ⁽³⁾	● ⁽³⁾
—P235/75R15 OWL all-season steel radial	O ⁽³⁾	O ⁽³⁾	● ⁽³⁾
Tire Upgrades—Ask dealer for details (see page 8 for tires with GVW upgrades)	O	O	O
Trailer Tow Preparation Group	O	O	O
Transfer Case, 4x4 System			
—Ram-Trac two-speed part-time 4x4 with shift-on-the-fly (150, 250)	S	S	S
—Heavy-duty two-speed part-time 4x4 gear drive with manual hubs and PTO provision (350, all diesel)	S	S	S
Vent—Driver-side Ram air at feet	S	S	S
Wheels—150: 15x6.5" steel with bright hubcaps	S	S	
—150: 15x6.5" styled steel wheels	O	O	●
—150: 15x6.5" cast aluminum road wheels			O
—250/350: 16x6" heavy-duty steel with bright hubcaps	S	S	
—250/350: 16x6" heavy-duty steel with bright trim rings	O	O	●
—350 dual rear wheel: 16x6" eight-bolt heavy-duty steel discs	S	S	S
Window—Sliding rear	O	O	●
Windshield Wipers—Two-speed	S		
—Deluxe with intermittent feature		●	●
Woodtone Instrument Panel Applique			●

S-STANDARD. O-OPTIONAL. ●-DISCOUNT PACKAGE EQUIPMENT.* ⁽¹⁾Diesel. ⁽²⁾250/350. ⁽³⁾150.
*Equipment in Customer-Preferred™ Discount Advantage Package gives you major options at NO CHARGE. See salesperson for details.

Dodge Ram Interior Dimensions

Head Room	40"	Hip Room	65"
Shoulder Room	64.2"	Leg Room	39.4"

Dodge Ram Pickup Model and GVW Selector

MODEL	GVW PKG.	AVAIL.	MODEL/PAYLOAD LBS.		AXLES		SPRING CAPACITY		TIRES
			Short	Long	Front	Rear	Front	Rear	
150 4x2	5,500	S	1,770	1,670	3,300	3,600	2,800	3,640	P215/75R15
	6,200	E	—	2,335	3,300	3,600	2,800	3,640	P235/75R15XL
150 4x2 Club	6,200	S	1,980	1,860	3,300	3,600	3,200	3,640	P235/75R15XL
	7,400	S	—	3,255	3,300	5,500	3,000	5,450	LT215/85R16
250 4x2	8,510	E	—	4,245	3,300	5,800	3,400	5,450	LT235/85R16
	7,400	S	—	2,945	3,300	5,500	3,400	5,450	LT215/85R16
250 4x2 Club	8,510	E	—	4,020	3,300	5,800	3,400	5,450	LT235/85R16
	8,700	S	—	4,335	3,300	6,200	3,400	7,300	LT235/85R16
350 4x2	10,100	E	—	5,400	4,000	6,900	3,300	7,300	LT215/85R16 Dual Rear
	10,100	S	—	4,565	4,000	6,900	4,000	7,300	LT215/85R16 Dual Rear
150 4x4	6,400	S	2,250	2,070	3,500	3,600	3,280	3,640	P235/75R15XL
150 4x4 Club	6,400	S	—	1,660	3,800	3,600	3,600	3,640	P235/75R15XL
250 4x4	7,500	S	—	2,920	3,500	5,500	3,280	7,300	LT215/85R16
	8,510	E	—	3,905	3,500	5,800	3,600	7,300	LT235/85R16
250 4x4 Club	7,500	S	—	2,690	3,800	5,500	3,600	7,300	LT215/85R16
	8,510	E	—	3,660	3,800	5,800	3,600	7,300	LT235/85R16
350 4x4	8,700	S	—	3,820	4,500	6,200	3,880	7,300	LT235/85R16
	10,100	E	—	4,830	4,500	6,900	3,880	7,300	LT215/85R16 Dual Rear
350 4x4 Club	10,100	S	—	4,075	4,500	6,500	5,000	7,300	LT215/85R16 Dual Rear

S—Standard. E—Extra cost.

Dodge Ram Pickup Dimensions

MODEL	WHEEL-BASE	OVERALL LENGTH*	PICKUP BOX			TAILGATE OPENING	WIDTH BETWEEN WHEEL-HOUSINGS
			Length	Width	Depth		
Regular Cab Short Bed	115"	193.8"	76.9"	70.0"	19.1"	67.36"	51.0"
Regular Cab Long Bed	131"	213.8"	96.9"	70.0"	19.1"	67.36"	51.0"
Club Cab Short Bed	133"	211.8"	76.9"	70.0"	19.1"	67.36"	51.0"
Club Cab Long Bed	149"	231.8"	96.9"	70.0"	19.1"	67.36"	51.0"

*Overall length shown without rear bumper.

- Available for all Club Cab models are these premium cloth high-back reclining bucket seats. A center console and rear side-facing jump seats with vinyl trim are included.
- The Super LE Package features this premium cloth bench seat with adjustable headrests. On Club Cab models the seatback is split and rear side-facing jumpseats in vinyl trim are included.

- Standard in the Work Special Package and available at extra cost on regular cab base and Work Advantage models with the base decor is this deluxe cloth-with-vinyl-trim bench seat with adjustable headrests.
- Standard on all base and Work Advantage models is this heavy-duty vinyl bench seat with headrests. On Club Cab models the seatback is split and rear side-facing jump seats with vinyl trim are included.

EXTERIOR PAINT COLORS (ALL COLORS ARE CLEAR COAT)	INTERIOR TRIM COLORS		
	Spice Tan	Crimson Red	Charcoal
1 Flame Red	●	●	●
2 Copper Metallic (extra cost)	●		●
3 Electric Blue Metallic			●
4 Dark Spectrum Blue Metallic (extra cost)	●		●
5 Emerald Green Metallic	●		●
6 Light Sand Metallic (extra cost)	●		●
7 Black	●	●	●
8 Sabre Gray Metallic (extra cost)		●	●
9 Silver Star Metallic		●	●
10 Bright White	●	●	●

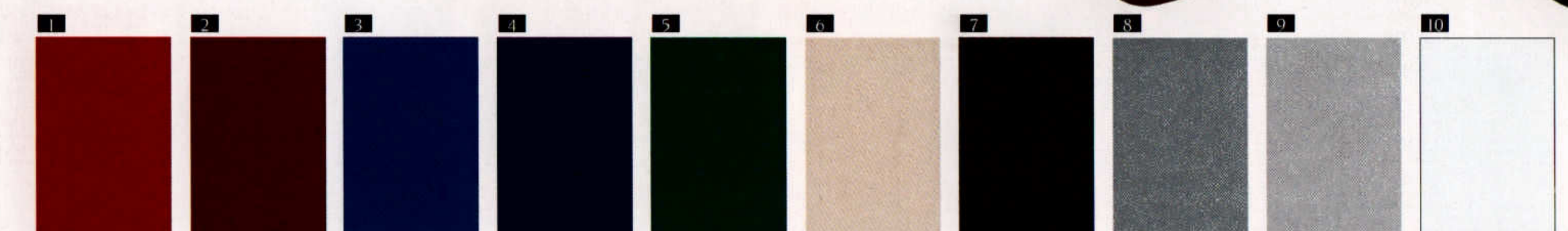

NOTE: Due to printing limitations, the colors shown will vary slightly from actual hues. See your Dodge dealer for accurate color chips.



Ram 350 Super LE Club Cab Dually



Power Ram 250 Super LE



Power Ram 150 Super LE



Ram 150 Work Special





Dakota Sport 4x4. Shown in Flame Red Clear Coat.



"Pickup Truck of the Year."

-Four Wheeler

An available MAGNUM 5.2-liter V8 is one of the reasons *Four Wheeler* magazine named the Dakota Club Cab 4x4 its 1992 Pickup Truck of the Year. And why Dakota is America's

best all-around pickup.

"Sane drivers will run out of tire, shock or nerve before this truck runs out of seamless power," said *Four Wheeler*. "...the Dakota is endless."

The rumble of a big V8 in the only midsize pickup around got the attention of the experts and will get yours, too. But that's to be expected. The MAGNUM 5.2-liter V8 is

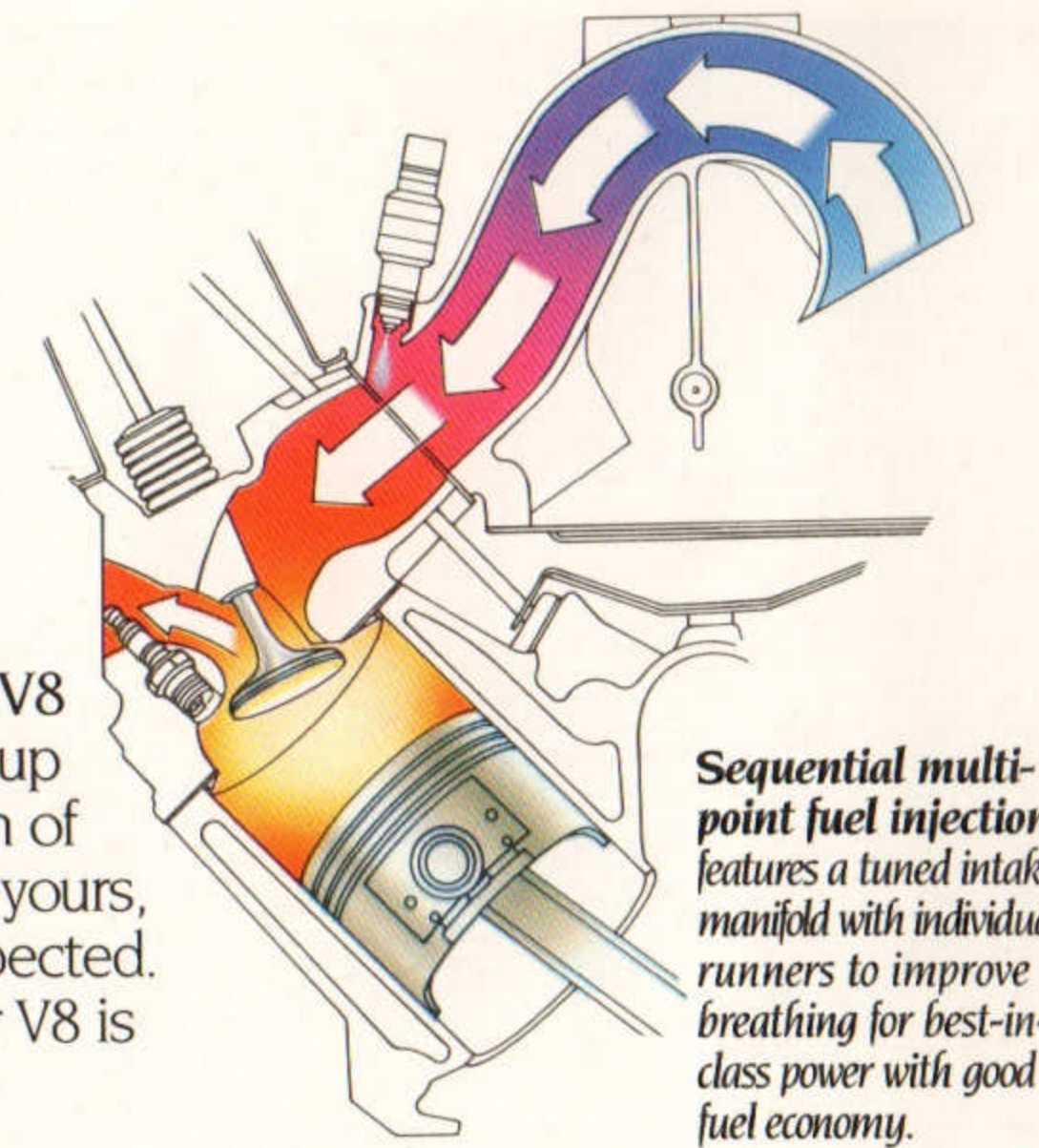

Sequential multi-point fuel injection features a tuned intake manifold with individual runners to improve breathing for best-in-class power with good fuel economy.

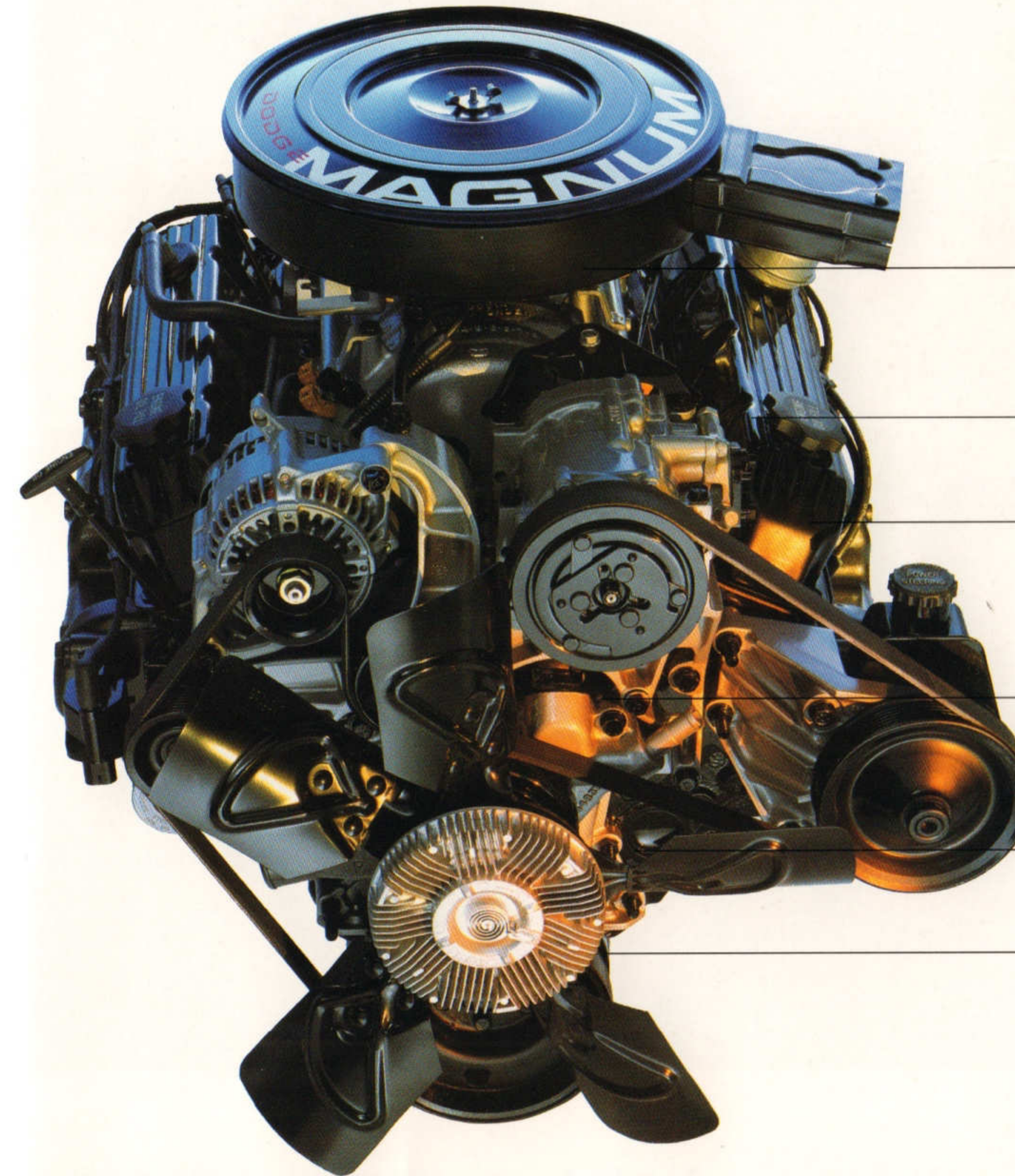

MAGNUM SMPI 5.2-liter V8

- **Progressive-bore throttle body** (patented by Dodge) for excellent engine response and more horsepower.
- **Sequential multi-point fuel injection** boosts horsepower and fuel economy.
- **Tuned intake manifold, large intake/exhaust valves and high-flow exhaust manifold** for efficient breathing and high horsepower delivery.
- **Combustion chambers, ports, pistons and ring package** designed for high horsepower and emissions control.
- **Serpentine belt accessory drive** for low maintenance and reduced engine vibration.
- **Plus features in the head, block and oil pan** for low weight, tight sealing and long life.

the same potent V8 offered on Dodge full-size Ram Pickups. It's why *Motor Trend* called the Dakota V8 "a true muscle truck" with "more horsepower than a Mustang GT... a stormer." Believe it!

The best-in-class power of a MAGNUM 3.9-liter V6 is also offered as standard or available, depending on the model. With the same state-of-the-art features as listed on the MAGNUM 5.2-liter V8 at the left, the MAGNUM 3.9-liter V6 kicks out 180 horsepower at 4,800 rpm and 225 pound-feet of torque at 3,200 rpm.

Or you can enjoy the reliable performance and economy of a 2.5-liter engine. No compact pickup offers you such a complete lineup of engines.

For state-of-the-art braking, a new four-wheel antilock brake system (ABS) is available in place of Dakota's standard rear-wheel antilock brake system.

Don't miss the fun of test-driving a midsize Dakota at your Dodge dealer. Coming, going or stopping, America's best all-around pickup is a powerful way to go trucking.

MAGNUM SMPI 5.2-liter V8

- 230 horsepower at 4,800 rpm.
- 280 pound-feet of torque at 3,200 rpm.

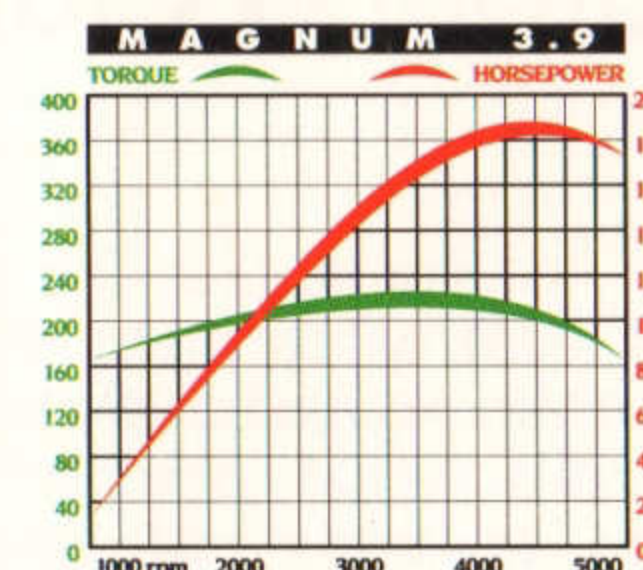
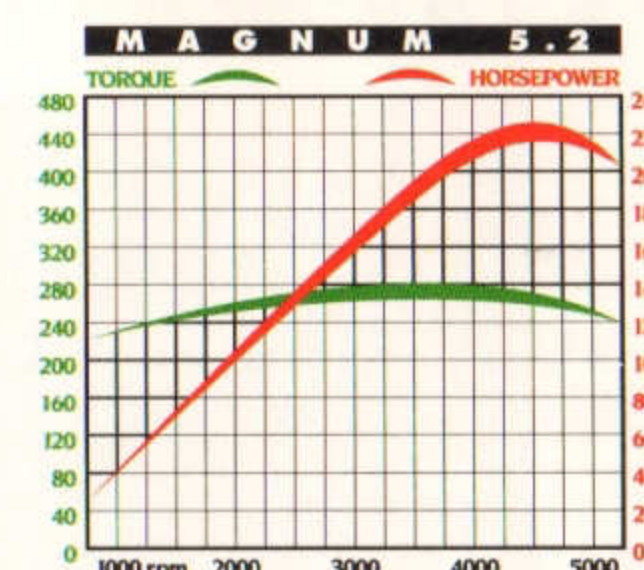

MAGNUM SMPI 3.9-liter V6 has the same features listed above on the MAGNUM 5.2-liter V8 for best-in-class V6 power:

- 180 horsepower at 4,800 rpm.
- 225 pound-feet of torque at 3,200 rpm.

"Pack this (V8) power in a midsize and comments come out like 'pocket rocket, ooo-weeh!'"

-Four Wheeler



America's best all-around Club Cab.

If a compact Club Cab is too small for your big jobs, but a full-size Club Cab is more truck than you want, Dakota Club Cab offers a unique solution: a midsize design that combines the best of both worlds.

Nineteen inches longer

inside than a Dakota regular cab, the industry's only midsize Club Cab has up to 25.2 cubic feet of extra cab space behind the front seat for more in-cab cargo room than any compact competitor, as well as more seating—for up to six people.

And Dakota Club Cab works harder with a longer, wider and deeper cargo box than extended cab compact pickups.

Payload capacities up to 2,000 pounds are available on Dakota Club Cabs—a higher maximum payload than any

compact competitor and comparable to payloads on some full-size pickups. To handle such loads, the full-size muscle of a MAGNUM V6 or a MAGNUM V8 is also available—another advantage the compact pickups don't offer.

"The Dakota (Club Cab) feels like a much larger truck...power made passing easy."
-Four Wheeler

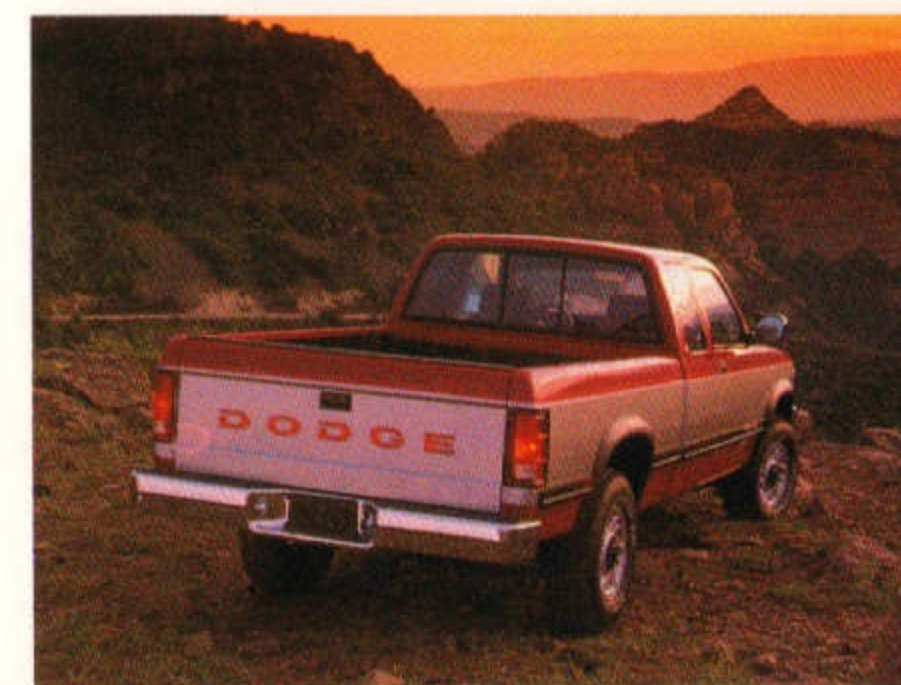

Test-drive a MAGNUM-powered Dakota Club Cab and you'll feel the combination of extra cab room, full-size performance and compact-size handling that put this Club Cab in a midsize class by itself.

"Three big pluses weigh in the Dakota's favor—size, power and handling."

-4-Wheel & Off-Road

Dakota Super LE Club Cab 4x4. Shown in Flame Red Clear Coat/Silver Star Metallic Clear Coat.



"The sports sedan of trucks."

-AutoWeek

Thanks to its unique midsize design, the Dakota Club Cab has a longer wheelbase than any compact extended cab: 131 inches. Whether you choose a two- or four-wheel-drive model, those extra inches of wheelbase make a difference you'll notice in this

unique Club Cab's smooth ride over bumps, tar strips and other on- and off-road surprises.

Dakota Club Cab handles like a compact-size pickup when parking, cornering, changing lanes or swooping through S-turns on a mountain road. Such

responsive handling in a pickup with full-size performance is the result of Dakota's midsize design, plus standard features like: • Gas-charged front and rear shock absorbers • Front stabilizer bar • Precise rack-and-pinion steering on 4x2 models

- Independent front torsion bar suspension on 4x4 models
- All-season steel radial tires... and more.

Customer-PreferredSM Advantage Packages let you add valuable equipment with big package discounts equal

"Out on the highway, the long wheelbase and relatively light truck yielded a smooth ride."

-Four Wheeler



to getting many items at NO CHARGE.* A Super LE Package, for example, includes popular items like air conditioning, stereo/cassette radio, aluminum road wheels, speed control and tilt

*Package savings based on price of equipment if purchased separately.

steering—all at NO CHARGE.* See the complete list of Super LE items on page 32.

"It drives like a full-size pickup, yet parks like a compact."

-AutoWeek

Dakota Super LE Club Cab 4x2. Shown in Electric Blue Metallic Clear Coat.

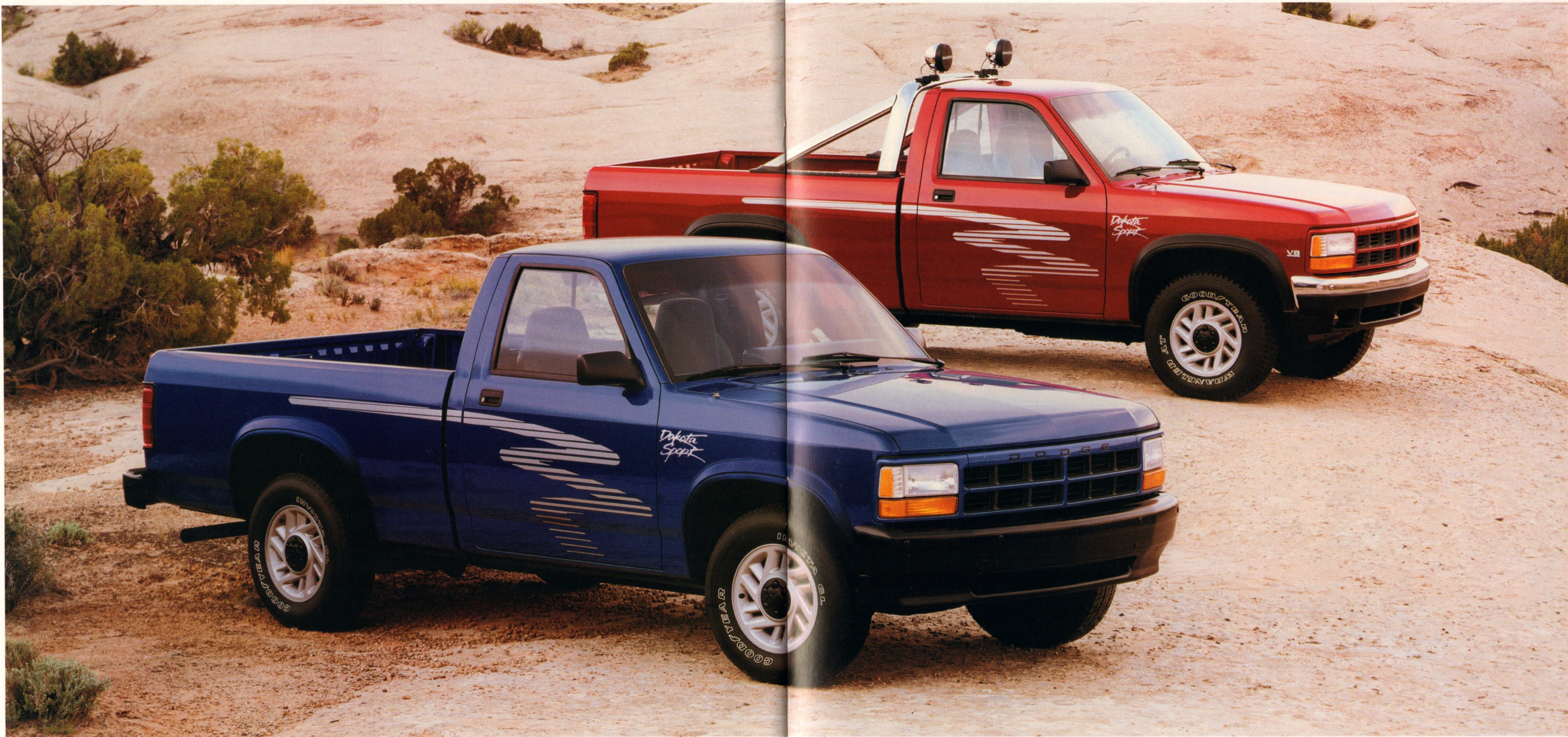

Own a pocket rocket with a MAGNUM V8.

Dakota's Sport Customer-PreferredSM Advantage Package lets you add major performance options to your Dakota at **NO CHARGE**.* cast-aluminum road wheels... outlined white-letter tires... cassette/stereo radio... cloth seats... rallye cluster

gauges... aero-type halogen headlights... "strobe whip" tape stripe... and more. See your salesperson for all the details and get a combination of MAGNUM power, street-smart styling and comfort not offered by any compact pickup.

No "tweaking" needed for the power hungry. Right out of the box, a MAGNUM V6 or V8 comes with sequential multipoint fuel injection, tuned intake system, high-flow exhaust, fist-sized intake/exhaust valves and other high-tech engineering

designed to make the most of all those cubic inches. All you have to do is buckle up, turn on the ignition and go!

Mopar dealer-installed accessories let you trick-up your new Dakota without leaving your Dodge dealer. And Mopar options

"...roquets off the line like a pit bull after the mailman."

-Motor Trend



can also add to your truck's value with:

- Accessory lighting
- Aerodynamic light bar
- Grille guards
- Bedliners
- Bed side rails
- Tonneau cover
- Rear window louver
- Tubular rear bumpers
- Tubular side steps
- Power

*Package savings based on price of equipment if purchased separately.

sliding rear window • Tool box... and much more. See your dealer for details.

"Just as impressive are the Dakota's 0-60-mph times... There are a lot of so-called performance cars that can't match these figures, and it is fun to put them to shame..."

-4-Wheel & Off-Road

Dakota 4x4 Sport shown in Flame Red Clear Coat. Dakota 4x2 Sport shown in Electric Blue Metallic Clear Coat.



Almost three-and-a-half tons of MAGNUM towing power.

Properly equipped with a MAGNUM V8 engine, midsize Dakota has up to 6,900 pounds of towing capacity. That's more towing power than any compact pickup offers you, and even more than some full-size pickups.

Dakota's transmissions are all built tough for long-haul towing reliability, and precisely matched to the engine you choose for smooth power delivery. Refer to the Driveline Chart on page 45 for specific engine and

transmission combinations.

A Trailer Tow Prep Package is available as a factory-installed option and includes: • Tachometer • Heavy-duty radiator • Auxiliary transmission oil cooler (auto. transmission only) • Auxiliary

power steering fluid cooler (V6 and V8 only) • 120-amp alternator • 810-amp maintenance-free battery • Heavy-duty flashers • 22-gallon fuel tank • Five-lead wiring harness. Equip your Dakota for towing with the help

"When stuffed full of 5.2-liter's worth of V8 engine, the handsome Dakota is a hauler in every sense of the word."

-Road & Track Truck & Van Buyer's Guide



of an expert who knows how to do it correctly the first time: your Dodge Truck dealer.

In payload capacity, midsize Dakota outworks compact pickups and even some full-size pickups. A regular cab two-wheel-drive Dakota can carry up to 2,550 pounds of payload, and a four-wheel-drive regular

cab up to 2,000 pounds.

For information on Dakota Chassis Cabs and other commercial applications, refer to the 1993 Dodge Work Truck Catalog or ask your salesperson.

"Racehorse or workhorse, it's your choice."

-Road & Track Truck & Van Buyer's Guide

Dakota Special LE 4x2. Shown in Dark Spectrum Blue Metallic Clear Coat and Light Sand Metallic Clear Coat. Shown with available bodyside and wheelflare molding.

Extra midsize room.

Dakota's unique midsize design provides extra inches of head, hip and shoulder room you and your passengers won't find in

car-like interior with standard features that include: • Tinted windows • Side-door demisters • Passenger-side storage tray



any compact pickup from Ford, Chevy or the imports. Why be squeezed?

Three adults can sit comfortably up front in all Dakotas on a standard bench seat, with integrated head restraints for added safety. And Dakota Club Cab models have 25.2 cubic feet of extra cab space behind the front seat—more than any compact club cab offers.

Three adults can also ride facing forward on Dakota Club Cab's available 60/40 split-folding rear seat, shown at the right; neither Ford nor Chevy offer three-across rear seating on their compact pickups. And, when you lift both sides of the 60/40 rear seat, you'll find hidden storage areas that let you hide valuables out of sight.

While Dakota is Ram-tough and capable, it also has a comfortable

The Dakota Special LE woodtone instrument panel includes a soft vinyl Sport steering wheel with optional cruise control mounted on the wheel arms, speedometer, oil pressure gauge, coolant temperature gauge, trip odometer and a tachometer (tachometer not available with the 2.5-liter engine).

- Two-place slide out beverage holder
- Soft-cloth headliner
- Three-point seat belt system for all outboard occupants... and more.

Dakota's Customer-PreferredSM Advantage Packages save you money on additional comfort and convenience items with big discounts that provide savings equal to the value of equipment like the Special LE trim package at NO CHARGE.* See page 32 for package contents and ask your salesperson to show you how Customer-PreferredSM Advantage Packages can make a Dakota affordable while adding to its value down the road.

*Package savings based on price of equipment if purchased separately.

"...we consider the Dakota a comfortable cruiser...a balanced, capable package with an outstanding (available V8) powerplant."

-Four Wheeler

The Dakota Special LE Club Cab interior, shown in Spice, features a 60/40 split bench front seat with folding center armrest, reclining seat-backs and adjustable driver-side lumbar support for lower back comfort.



Dodge Dakota Selected Standard and Optional Equipment

Super LE (Club Cab only)	Special LE	Sport	Work (Long wheelbase model only)	Base	S (Regular Cab only)
Air Conditioning	O	O	O	O	●
Alternator—75-amp	S	S	S	S	S
Axle—Sure Grip Differential	O	O	O	O	O
Battery—600-amp maintenance free	S	S	S	S	S
Brakes, Power-Assisted—Front disc, rear drum with antilock	S	S	S	S	S
Brakes, 4-Wheel Antilock	O	O	O	O	O
Bright Package—Bright front bumper with sport air dam and fog lights and bright rear step-type bumper				O	
Bumper, Front—Black with lower air dam	S	S	S	S	
—Bright with lower air dam					● ●
Bumper, Rear—Black with step pad	O	O	O	●	
—Bright with step pad					● ●
Cigar Lighter	S	S	S	S	S
Clutch—Hydraulic actuation (8.9" diameter—4x2, 10.5" diameter—4x4)	S	S	S	S	S
Cooling—Maximum engine		O	O	O	O
Cup Holder—Two-place on instrument panel	S	S	S	S	S
Door Trim—Full length with armrest	S	S	S	S	
—With cloth applique and lower carpet					● ●
Electrical—Heavy-duty: 810-amp battery/120-amp alternator		O	O	O	O
Floor Covering—Black rubber mat	S	S	S		O
—Carpeting					● S
—Accessory carpeted floor mats					● ●
Frame—36,000 psi high-strength carbon steel ladder type	S	S	S	S	S
Fuel Tank—15-gallon	S	S	S		
—22-gallon	O	●	O	●	●
Gauges—Analog type includes 85-mph speedometer, engine temperature, fuel, oil pressure, voltmeter and trip odometer	S	S	S		
—Rallye cluster with tachometer and 125-mph speedometer plus all gauges listed above		O	O	●	●
Glass—Tinted: all windows	S	S	S	S	S
—Vented rear quarter windows (Club Cab)			S	S	S
—Deep tint quarter windows (Club Cab)					● ●
Grille—Argent painted with "Dodge" letters	S	S	S		
—Bright with "Dodge" letters					● ●
—Body-color with "Dodge" letters					●
Headlights—Halogen sealed beam	S	S	S		
—Halogen aero-type					● ● ●
Headliner—Soft, cloth-covered	S	S	S	S	S
Heater—Engine Block	O	O	O	O	O
Light Group—Interior upgrade including underhood light	O	O	O	●	●
Mirrors—5"x7" dual black	S	S	S		
—5"x7" dual black remote		O	O	O	● ●
—6"x9" dual bright		O	O		
—6"x9" dual bright power					O
Moldings—Lower bodyside and wheel flare				O	●
—Wheel flare only (4x4)					●
Off-Road Appearance Group—Chrome front and rear bumpers, two front fog lights, and chrome light bar with two off-road lamps				O	
Paint—Premium exterior paint with Clear Coat finish and protective lower body antichip coating	S	S	S	S	S
—Two-tone paint treatment, lower bodyside	O	O	O	O	O
—Two-tone paint treatment, center band	O	O	O	O	O

S-STANDARD. O-OPTIONAL. ●-ADVANTAGE PACKAGE EQUIPMENT.
 *Equipment in Customer-Preferred™ Discount Advantage Package gives you major options at NO CHARGE. See salesperson for details.

Super LE (Club Cab only)	Special LE	Sport	Work (Long wheelbase model only)	Base	S (Regular Cab only)
Pickup Box—Double-wall construction with two-tier loading and one-piece high-strength steel floor	S	S	S	S	S
Power Windows and Door Locks					O
Protection Package—4x4 skid plates for fuel tank, transfer case and front axle				O	O
Radio—AM/FM stereo with clock (two speakers)	O	S	S		
—AM/FM stereo, cassette with clock (four speakers)	O	O	●	● ●	
—AM/FM stereo, cassette with seek-and-scan, clock, graphic equalizer (four speakers)					O
Seats—Heavy-duty three-man vinyl bench (60/40 split bench with center armrest on Club Cab)	S	S	S		
—Deluxe cloth three-man bench (60/40 split bench with center armrest on Club Cab)	O	O	O	●	
—Premium cloth three-man bench (60/40 split bench with center armrest and lumbar adjustment on Club Cab)					● ●
—60/40 rear bench flip-type seats (Club Cab only)		O	O	● ● ●	
Shock Absorbers—Gas-charged, long life	S	S	S	S	S
Snowplow Preparation Group (4x4 only)		O	O	O	O
Speed Control and Tilt Steering Group					O
Stabilizer Bar (4x4 and Club Cab)		S	S	S	S
Steering—Rack and pinion (4x2), recirculating ball (4x4)	S	S	S	S	S
—Power-assisted (Standard on 4x4)	O	O	● ● ● ●	● ●	
Storage Tray—Behind seat on Regular Cab (standard under Club Cab rear seat)					● S
Suspension—Front independent coil spring (4x2)	S	S	S	S	S
—Front independent torsion bar (4x4)	S	S	S	S	S
Suspension, Heavy-duty—Heavy-duty shock absorbers and stabilizer bar				O	O
Tailgate—Removable with caliper lock latches	S	S	S	S	S
Tape Stripe—Upper body and tailgate accents					● ●
—"Strobed Whip" sport stripe					●
Tilt Steering Column (without Speed Control)		O	O	O	●
Tires—P195/75R15 BSW all-season steel radial (4x2)	S	S	S		
—P205/75R15 BSW all-season steel radial (4x4)	S	S			
—P215/75R15 BSW all-season steel radial (4x2)	O	O			●
—P215/75R15 OWL all-season steel radial (4x2)					● ●
—P235/75R15 BSW all-season steel radial (4x4)					● ●
—P235/75R15 OWL all-terrain steel radial (4x4)					● ●
—Full-size spare tire (matches other tires)	S	S	S	S	S
Trailer Tow Preparation Group		O	O	O	O
Transfer Case—Ram-Trac two-speed part-time 4x4 with shift-on-the-fly (4x4 only)	S	S	S	S	S
Wheels/Wheel Trim—15" cast aluminum					● ●
—15" styled steel with center cap and bright trim rings	O	O			●
—15" steel with center cap	S	S	S		
Window—Rear sliding	O	O	O	O	● ●
Windshield Wipers—Two-speed	S	S	S		
—Intermittent wipe		O	O	● ● ●	
Woodtone Instrument Panel Applique (others are black)					● ●

Dodge Dakota Pickup Model/Payload Selector

MODEL	MIN. GVWR	AVAIL.	MODEL/PAYLOAD LBS.		AXLES		SPRINGS @ GRD		TIRES
			Short	Long	Front	Rear	Front	Rear	Front and Rear
Dakota S	4,230	S	1,250		3,300	3,850	2,800	2,700	P195/75R15
Dakota 4x2	4,290	S	1,250		3,300	2,300	2,800	2,700	P195/75R15
	4,380			1,250					
Dakota 4x4	4,890	E	1,800		3,300	3,850	2,800	3,000	P205/75R15
	4,980			1,800					
Dakota Club Cab 4x2	5,950	E	2,550		3,300	3,850	2,800	3,850	LT215/75R15
	5,990			2,550					
Dakota Club Cab 4x4	4,750	S	1,450		3,300	3,850	2,800	3,000	P195/75R15
	5,600	E	2,000		3,300	3,850	2,800	3,850	LT215/75R15
Dakota 4x4	5,170	S	1,450		3,400	3,850	3,400	3,000	P195/75R15
	5,200			1,450					P205/75R15
Dakota Club Cab 4x4	5,790	E	2,000		3,400	3,850	3,400	3,850	P235/75R15
	5,830			2,000					
Dakota Club Cab 4x4	5,420	S	1,450		3,400	3,850	3,400	3,000	P215/75R15
	5,800	E	1,800		3,400	3,850	3,400	3,850	P235/75R15

S—Standard. E—Extra cost.

Dodge Dakota Pickup Dimensions

MODEL	WHEEL-BASE	OVERALL LENGTH ⁽¹⁾	WIDTH	HEIGHT	PICKUP BOX				
					Length	Width	Depth	Tailgate Opening	Width Between Wheel-housings
Regular Cab Short Bed	112"	189.1"	68.4"	64.2" ⁽²⁾	6.5'	59.6"	17.5"	57.5"	44.9"
Regular Cab Long Bed	124"	207.5"	68.4"	64.2" ⁽²⁾	8.0'	59.6"	17.5"	57.5"	44.9"
Club Cab Short Bed	131"	208.1"	68.4"	64.2" ⁽²⁾	6.5'	59.6"	17.5"	57.5"	44.9"

⁽¹⁾ Without rear bumper. ⁽²⁾ 67.1" on 4x4 models. ⁽³⁾ 67.2" on 4x4 models.

Dodge Dakota Interior Dimensions

Head Room—front	39.5"	Leg Room—front	41.8"
Shoulder Room—front	58.0"	Space Behind Seat (Club Cab)	25.2" cu ft ⁽¹⁾
Hip Room—front	56.0"		

⁽¹⁾ Without rear bench seat.

- Premium cloth reclining high-back bucket seats with center console are available for all Special LE, Super LE and Sport models. The driver's seat has a four-position manual lumbar adjustment.
- A premium cloth 60/40 split bench reclining seat is standard with Special LE and Super LE Club Cab models. Features include a folding center armrest, adjustable headrests and driver-side lumbar adjustment. A fold-up 60/40 split rear bench seat is included on Club Cab models.
- Standard on base Club Cab models is a 60/40 split bench reclining seat made

EXTERIOR PAINT COLORS (ALL COLORS ARE CLEAR COAT)	INTERIOR TRIM COLORS		
	Spice Tan	Crimson Red	Charcoal
Flame Red	●	●	● ⁽¹⁾
Copper Metallic (extra cost)	●	●	●
Light Sand Metallic (extra cost)	●	●	●
Dark Spectrum Blue Metallic (extra cost)	●	●	●
Emerald Green Metallic	●	●	● ⁽¹⁾
Electric Blue Metallic	●	●	● ⁽¹⁾
Black	●	●	● ⁽¹⁾
Sabre Gray Metallic (extra cost)	●	●	●
Silver Star Metallic	●	●	●
Bright White	●	●	● ⁽¹⁾

⁽¹⁾ Sport models available in these combinations only.

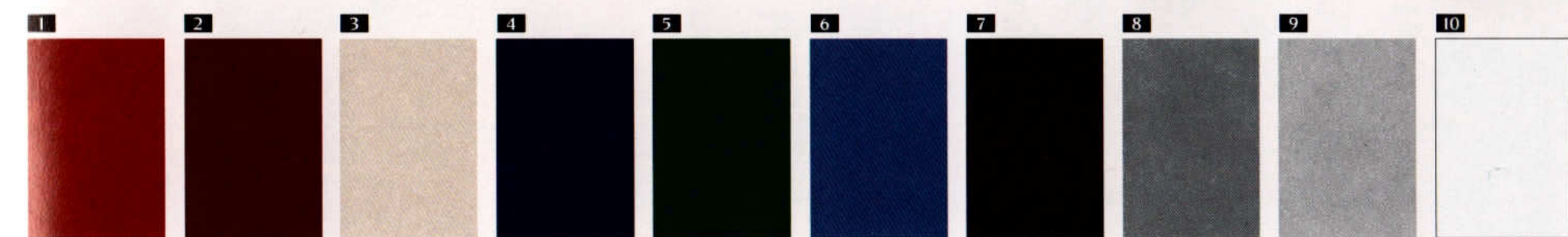

NOTE: Due to printing limitations, the colors shown will vary slightly from actual hues. See your Dodge dealer for accurate color chips.



Dakota Super LE Club Cab 4x4



Dakota Sport 4x4



Dakota Special LE



Dakota (base)

of heavy-duty vinyl with a folding center armrest and adjustable head restraint for outboard seating positions. A similar seat in deluxe cloth is standard on Sport models and available on base models. A rear 60/40 fold-up bench seat is standard on Sport models and included with the optional deluxe cloth seat on base models.

- Special LE regular cab models feature this premium cloth bench seat with a fold-down armrest and adjustable head restraints for outboard seating positions.
- Bench seats, made of heavy-duty vinyl, are standard on Dakota S, base and Work models and optional on Special LE models. A similar seat in deluxe cloth is standard on Dakota Sport and available on S, base and Work models.





Ramcharger 4x4, shown in Flame Red Clear Coat and Light Sand Metallic Clear Coat.

 "...will get you where you're going, do whatever you ask, and bring you back..."

-Road & Track Truck & Van Buyer's Guide

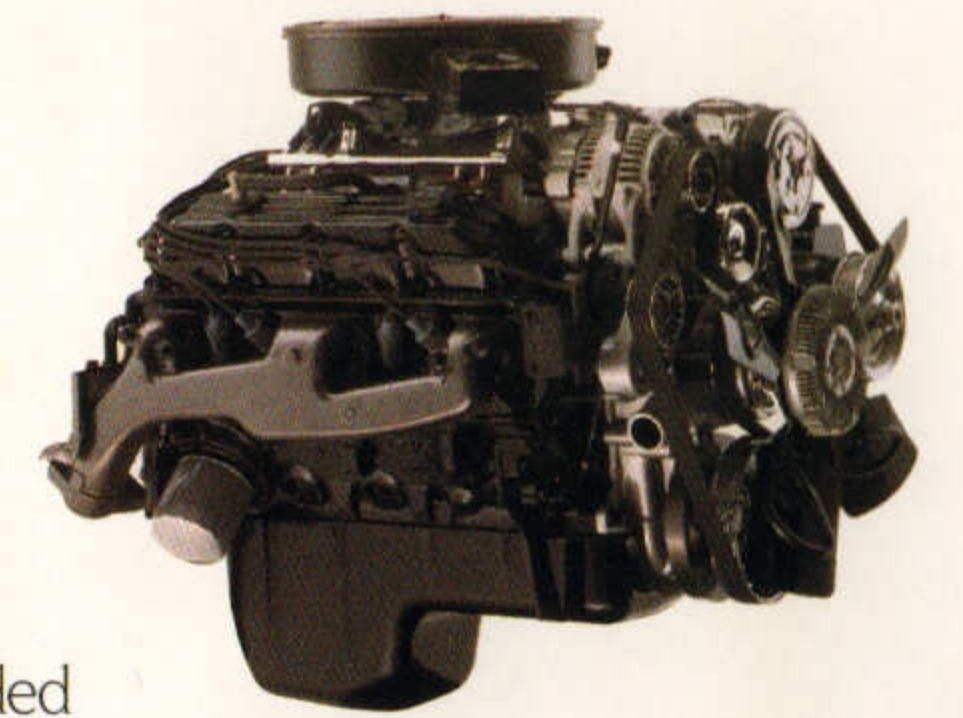

Ramcharger's optional new MAGNUM 5.9-liter MPI V8 pumps out 230 horsepower at 4,000 rpm and 325 pound-feet of torque at 3,200 rpm. Both ratings are best-in-class.

America's most powerful sport utility vehicle continues to out-horse the competition with even more MAGNUM power in 1993.

In addition to the standard MAGNUM 5.2-liter V8, Ramcharger offers an available new MAGNUM 5.9-liter V8 —

both packed with proven state-of-the-art engine technology (described on page 9) for more horsepower and torque than any competitive engine of comparable size.

Not sure you need four-wheel drive? It's a must if you plan to

go off-road, and recommended for extra traction on muddy or snowy roads. But if four-wheel drive isn't right for your needs, you can still enjoy a Ramcharger without it. Unlike Ford and Chevy, Dodge gives you the advantage of choice by

making Ramcharger the only full-size sport utility vehicle available as a 4x4 or 4x2 model. You decide.

And if you do choose a Ramcharger 4x4, you'll get Ram-Trac shifting so you can shift-on-the-fly between two- and four-wheel-drive High while traveling at speeds up to 55 mph.

For a smooth, level ride, every Ramcharger features computer-selected springs and gas-charged shock absorbers all around. And two-wheel-drive Ramchargers take on rough roads with an independent front suspension, while four-wheel-drive models have a solid front axle for extra strength when the road disappears and you're on your own. To help stop you safely wherever you drive, computer-controlled



Ramcharger LE and Canyon Sport feature high-back bucket seats, full center console, full carpeting, and a folding rear bench seat for optimal cargo space. LE interior shown in Charcoal.



Ramcharger has more overall interior room and rear cargo capacity than Ford Bronco.

rear-wheel antilock brakes are standard.

Capable, comfortable and Ram-tough, a MAGNUM-powered Ramcharger is the ultimate sport utility vehicle.

"It looks like a near bullet-proof vehicle...Looks, in this case, don't deceive."

-Road & Track Truck & Van Buyer's Guide

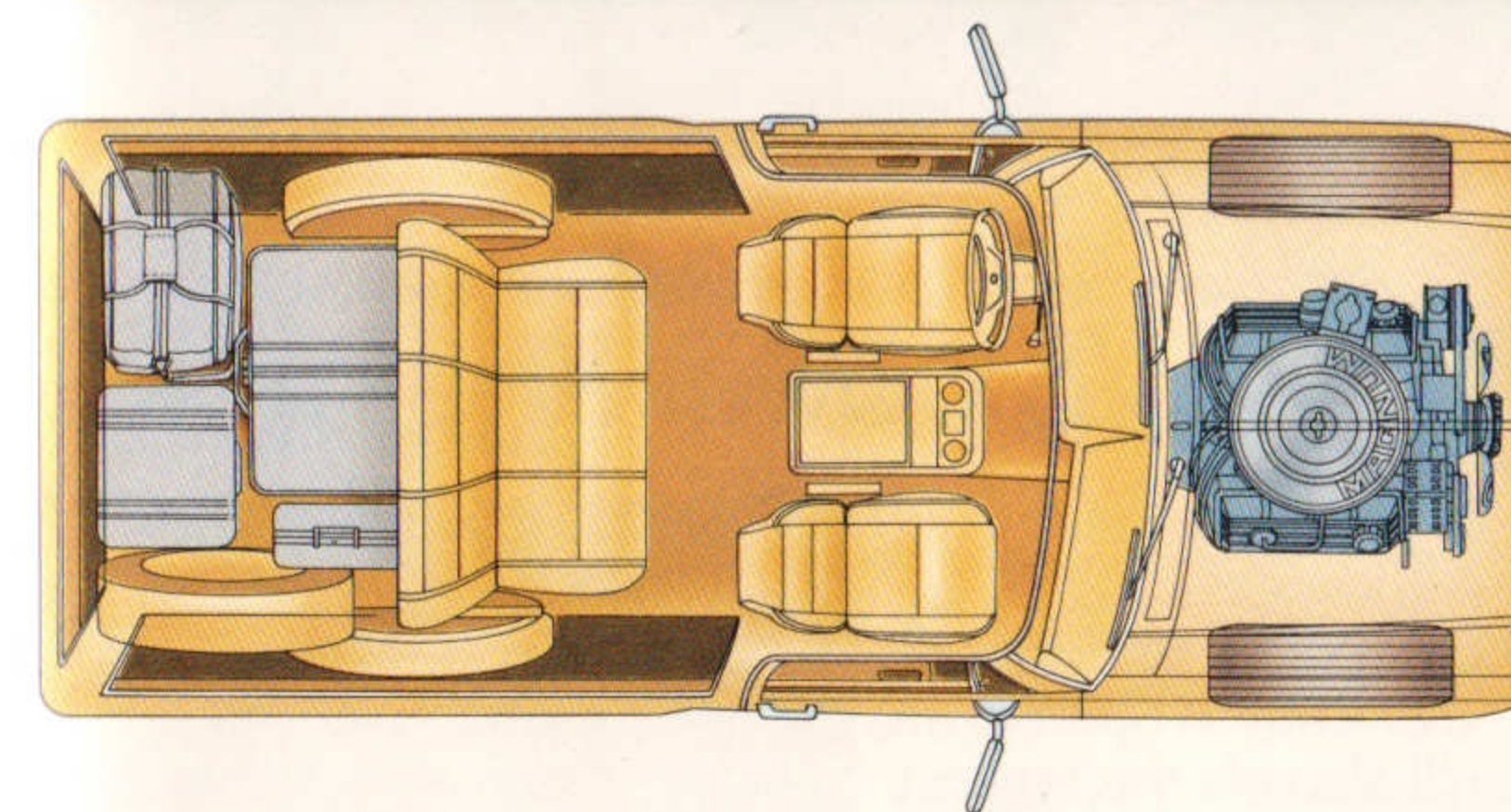

Folding rear seat offers more interior cargo room than Ford Bronco or Chevy Blazer: 86.1 cubic feet. Remove the seat for up to 105.7 cubic feet.

70.0 inches of cargo length from the front seatback to the tailgate. All-steel roof is more resistant to squeaks and rattles than Ford Bronco's

bolted-on piece of fiberglass. Tough double-wall construction is used in doors, tailgate, fenders and other critical areas.

Galvanized steel is used throughout as part of a seven-step process to resist corrosion.

Versatile seating for five is standard; six is optional.



The only sport utility with MAGNUM V8 power and more.

A Dodge Ramcharger Canyon Sport can take you on- or off-road with a combination of power, comfort and convenience features unmatched by any other sport utility vehicle: • MAGNUM V8 engine • Automatic transmission • Air conditioning • Power

windows and door locks • Electronic speed control • Tilt steering • Rear window defroster • Four-speaker AM/FM stereo cassette radio • Premium Austin cloth seats • Center floor console. And all this comes with a big discount equal to NO CHARGE*

on equipment like air conditioning and other Canyon Sport extras. You'll also get the biggest towing and payload ability in a sport utility. Properly equipped, a two-wheel-drive Ramcharger outworks the competition with 7,500 pounds of towing capacity

and 1,375 pounds of payload power. Ramcharger 4x4 models offer the same towing capacity and an even higher payload rating of up to 1,785 pounds. Plus: the industry's best limited truck warranty protection backs your Ramcharger with

Standard 4x4 Canyon Sport features include a MAGNUM V8 engine, automatic transmission, heavy-duty transfer case, all-season outlined white letter tires and a 600-amp battery.



Chrysler Corporation's unique Owner's Choice Protection Plan. See page 43 and your dealer for details on these limited warranties. *Package savings based on price of equipment if purchased separately.

"It's a macho machine with a uniquely American cut and swagger."

-Car & Driver

Ramcharger Canyon Sport 4x2 and 4x4 models available in Black Clear Coat, Bright White Clear Coat, Flame Red Clear Coat and Emerald Green Clear Coat—all with a secondary lower color of Light Sand Metallic Clear Coat.

Ramcharger Selected Standard and Optional Equipment

Canyon Sport						Canyon Sport					
LE						LE					
Base						Base					
S-Plus						S-Plus					
S						S					
Air Conditioning	O	●	O	●	●	Paint, Two-Tone—Lower bodyside paint break		O	O	●	
Alternator—90-amp	S	S	S	S	S	—Center band paint break		O	O		
—120-amp			O	O	O	Power Windows and Door Locks		O	●	●	
Axle—Sure Grip Differential	O	O	O	O	O	Radio—Delete standard radio: for credit	S	O			
Battery—600-amp	S	S	S	S	S	—AM/FM stereo	O	●	S		
—810-amp			O	O	O	—AM/FM stereo, cassette (four speakers)	O	O	O	●	●
Brakes—Front disc, rear drum with antilock	S	S	S	S	S	—AM/FM stereo, cassette with seek-and-scan		O	O	O	
Bumper, Front—Bright with step pads and guards			O	●		Roof Vent	S	S	S	S	S
—Painted Light Sand with step pad and guards					●	Seats—All-vinyl high-back buckets	S	S	S		
Bumper, Rear—Painted Light Sand with step pad					●	—Deluxe cloth high-back buckets	O	O	O		
—Step-type, bright finish	O	O	O	O		—Premium cloth high-back buckets				●	●
—Step-type, painted Light Sand					O	—Premium cloth split-back bench seat (no-cost option)				O	O
Buzzer—Key-in-ignition, headlights on, fasten seat belts	S	S	S	S	S	—Rear bench seat in matching front seat material	S	S	S	S	S
Canyon Sport Decor Group					●	Service—Identification for dip stick, oil fill cap, power steering reservoir, coolant overflow bottle, windshield washer fluid	S	S	S	S	S
Console—Between seats					●	Skid Plate—Fuel tank	O	O	O	O	O
Cooling—Maximum engine			O	O	O	—Transfer case (4x4 models only)	O	O	O	O	O
—Auxiliary transmission			O	O	O	Speed Control and Tilt Steering Group	O	O	O	●	●
Defroster—Electric rear window	O	O	O	●	●	Stabilizer Bar			O	O	O
Fuel Tank—34-gallon	S	S	S	S	S	Steering—Power-assisted	S	S	S	S	S
Gauges—Oil pressure, engine temperature, trip odometer and voltmeter	S	S	S	S	S	Sun Visor—Dual vinyl	S	S	S	S	S
Grille—Bright finish	S	S	S	S		Sunscreen Glass	O	O	O	●	●
—Painted body color					S	Tape Stripe—Upper bodyside					●
Headliner—Full, soft deluxe cloth	S	S	S	S	S	Tilt Steering Column without Speed Control			O		
Heater—Engine block	O	O	O	O	O	Tires—P235/75R15XL OWL	O	O	O	O	●
LE Decor Group					●	—P235/75R15XL BSW	S	S	S	S	
Light Group, Interior Upgrade—Including underhood light	O	●	O	●	●	—31x10.5R15XL OWL (4x4 models only)			O	O	O
Message Center—Includes maintenance required, brake, antilock brake, low oil and check engine warning lights. Also includes four-speed automatic transmission overdrive switch	S	S	S	S	S	Trailer Tow Preparation Group			O	O	O
Mirrors—6"x9" dual, power			O	●	●	Wheels—Argent with hubcap	S	S	S		
—7"x10" dual, manual			O	O	O	—Styled steel, argent painted			O	●	
Moldings—Lower bodyside and wheel flare			O	●	●	—Cast aluminum			O	O	●
						Windshield Wipers—Two-speed	S		S		
						—Deluxe with intermittent wipe	O	●	O	●	●

S-STANDARD. O-OPTIONAL. ●-DISCOUNT PACKAGE EQUIPMENT*

*Equipment in Customer-Preferred™ Discount Advantage Package gives you major options at NO CHARGE. See salesperson for details.

Dodge Ramcharger Dimensions

MODEL	WHEEL-BASE (IN.)	WIDTH (IN.)	CARGO VOL. (CU FT)			CARGO AREA DIMENSIONS (IN.)		
			HEIGHT (IN.)	Rear Seat Folded Down	Without Rear Seat	Length	Width	Height
4x2	106	79.5	69.72	86.1	105.7	70.0	62.5	41.8
4x4	106	79.5	73.06	86.1	105.7	70.0	62.5	41.8

1. Premium cloth, high-back front bucket seats feature inboard folding armrests and seatback recliners. Standard on models equipped with the LE Decor and Canyon Sport Packages.*

2. A premium cloth split-back front bench seat is available as a no-cost option on models equipped with the LE Decor and Canyon Sport Packages.*

3. Optional seats for S and base models are available in deluxe cloth. These high-back front bucket seats feature inboard folding armrests.*

4. Heavy-duty vinyl high-back front bucket seats are standard on all S and base models. A rear bench seat in matching trim is included.

*A forward folding rear bench seat, trimmed to match front seat, is standard on all models.



1.



2.



3.



4.

INTERIOR TRIM COLORS

EXTERIOR PAINT COLORS (ALL COLORS ARE CLEAR COAT)	Spice Tan	Crimson Red	Charcoal
1 Flame Red	●	●	●
2 Copper Metallic ⁽¹⁾ (extra cost)	●		●
3 Electric Blue Metallic			●
4 Dark Spectrum Blue Metallic (extra cost)	●		●
5 Light Sand Metallic (extra cost)	●		
6 Emerald Green Metallic ⁽¹⁾			●
7 Black	●	●	●
8 Sabre Gray Metallic (extra cost)		●	●
9 Silver Star Metallic		●	●
10 Bright White	●	●	●

⁽¹⁾Not available on S models.



NOTE: Due to printing limitations, the colors shown will vary slightly from actual hues. See your Dodge dealer for accurate color chips.



Ramcharger S



Ramcharger LE



Ramcharger Canyon Sport

Dodge Ramcharger GVW Package Selector

MODEL	GVW PKG	WHEELBASE (IN./PAYLOAD)	AXLES		SPRINGS @ GRD		TIRES
			Front	Rear	Front	Rear	
4x2	5,600	106/1,375 106/1,365	3,000	3,600	2,600	3,640	P235/75R15XL
4x4	6,000	106/1,430 106/1,420	3,500	3,600	3,280	3,640	P235/75R15XL
4x4	6,400 ⁽¹⁾	106/1,785	4,000	3,600	4,200	3,640	P235/75R15XL

⁽¹⁾Included in and only available with Light-Duty Snowplow Preparation Package.



Dodge Power Ram 50 shown in Bright Red.

 "When reliability counts, Ram or Power Ram 50s will be there to be counted."

-Road & Track Truck & Van Buyer's Guide

A lower price, excellent fuel economy, and bumper-to-bumper advantages make Dodge Ram 50 one of today's best values in a small pickup. If you're looking for your first truck, you'll find a Ram 50 to

be just about ideal. If you're an experienced truck owner, you'll be pleased by how much truck a Ram 50 offers, especially for the price.

Choose from a short- or long-wheelbase two-wheel-drive

Ram 50 and a short-wheelbase four-wheel-drive Power Ram 50 model. You'll get a standard 2.4-liter engine with the economical power you need to take on the boulevard or the back country, plus the precise response of a



A lockable, rustproof tool box and many other Mopar accessories are available as dealer-installed options.

five-speed manual transmission with overdrive.

To get you off-road and back, Power Ram 50 comes with skid plates and smooth-riding independent front torsion-bar suspension, plus automatic locking front hubs so you can make fast shifts from two-wheel drive to four-wheel drive without leaving the cab.

With a standard payload rating of 1,580 pounds, Ram 50 is the small pickup you can take out on a big job, while a four-wheel-drive Power Ram 50 can haul a payload on- or off-road up to 1,805 pounds. Properly equipped, both models can tow up to 3,500 pounds. And they stop you and those loads with computer-controlled rear-wheel antilock brakes, standard for 1993.

Dealer-installed Mopar options let you customize your Ram 50 without leaving your Dodge dealer... with: • Air conditioning • Running boards • Rear window louvers • Accessory lighting • Aerodynamic light bar • Tube-type rear step bumper • Four-speaker AM/FM stereo cassette radio... and more.

For basic value, Ram-tough reliability and the fun of a small pickup, be sure to check out a '93 Dodge Ram 50.



Dodge Power Ram 50, shown in Dark Silver Metallic.



Reclining cloth bucket seats trimmed with vinyl are standard for SE models, shown in Charcoal.



Ram 50 SE features a Sport soft-feel steering wheel and full instrumentation with a trip odometer and tachometer, plus gauges for fuel, voltage, temperature and oil pressure.

"...all members of Dodge's mini-truck family fill a basic and very important need: They can get the job done."

-Road & Track Truck & Van Buyer's Guide

RAM 50 Selected Standard and Optional Equipment

Power Ram 50 4x4	Ram 50 SE	Ram 50
Air Conditioning	O	O
Axle—Sure Grip Differential		O
Brakes, Power-Assisted—Front disc, rear drum with antilock	S	S
Bumper, Front—Dark Gray	S	S
—Color-Keyed		S
Bumper, Rear—Black	O	
—Bright		O
—Tube-type, black		O
Cargo Light—Cab rear	P	S
Carpeting	S	S
Exhaust System—Full stainless steel	S	S
Floor Mats—Accessory	O	O
Fuel Tank—13.7-gallon (SWB only)	S	S
—18.2-gallon (LWB only)	S	
—15.8-gallon (SWB only)		S
Instrument Cluster—Analog gauges: fuel, coolant temperature, 115 mph speedometer, odometer, trip odometer	S	S
—Rallye cluster with tachometer, oil pressure and voltmeter gauges		S
Headliner, Cloth Covered	S	S
Heater/Defroster—With side window demisters	S	S
Mirrors—Dual, black	S	S
—Dual, low-mount black	O	O
—Dual, low-mount bright		O
Moldings—Bodyside, black with bright accent	O	S
Mudguards—Front and rear		S
Power Windows and Door Locks		O
Radio—AM/FM stereo	O	O
Skid Plates and Front Tow Hook		S
Steering—Power-assisted	O	S
Suspension—Front independent coil spring (4x2)	S	S
—Front independent torsion bar (4x4)		S
Tilt Steering Column	S	S

Power Ram 50 4x4	Ram 50 SE	Ram 50
Tires (set of five)		S
—P195/75R14 BSW all-season steel radial		S
—P195/75R14 OWL all-season steel radial	O	S
—P205/75R14 OWL all-season steel radial		O
—P225/75R15 BSW all-terrain steel radial		S
—P225/75R15 OWL all-terrain steel radial		O
—Full size spare tire (matches other tires)	S	S
Transfer Case—Two-speed part-time 4x4 with automatic locking hubs		S
Under Seat Storage—Left and right outboard seats	P	S
Wheels (set of four)		S
—14" styled-steel, painted argent		S
—14" wide spoke, bright	O	S
—15" wide spoke, painted argent		S
—15" wide spoke, bright		O
Window—Rear sliding	O	O

S-STANDARD. O-OPTIONAL EQUIPMENT. P-PACKAGE ONLY.

Dodge Ram 50 Interior Dimensions

Head Room	38.8"	Hip Room	50.8"
Shoulder Room	55.5"	Leg Room	42.0"

Dodge Ram 50 Model/Payload Selector

MODEL	PAYLOAD (LBS)
Ram 50 4x2 Short Bed	1,580
Ram 50 4x2 Long Bed	1,560
Ram 50 SE 4x2 Short Bed	1,575
Power Ram 50 4x4 Short Bed	1,805

Dodge Ram 50 Dimensions

	WHEEL-BASE	OVERALL LENGTH ¹⁾	OVERALL WIDTH	OVERALL HEIGHT	PICKUP BOX (IN.)		
					Length	Width	Depth
Ram 50 Short Bed	105.1"	177.2	65.1	58.5	72.0	55.7	15.4
Ram 50 Long Bed	116.1"	193.7	65.1	58.3	88.3	55.7	15.4
Power Ram 50 Short Bed	105.5"	176.9	65.1	64.4	72.0	55.7	15.4

¹⁾Without rear bumper.



1. Premium cloth low-back reclining bucket seats with see-through adjustable head restraints are standard on Ram 50 SE models. Includes center floor console.
2. Standard on base models is a heavy-duty vinyl bench seat with adjustable head restraints.



Ram 50 Long Bed



Ram 50 Short Bed

EXTERIOR PAINT COLORS (ALL COLORS ARE CLEAR COAT)	INTERIOR TRIM COLORS	
	Sand	Charcoal
1 Emerald Green Pearl Coat		●
2 Blue Pearl Coat		●
3 Bright Red		●
4 Dark Silver Metallic		●
5 Blue Green ⁽¹⁾		●
6 White	●	●

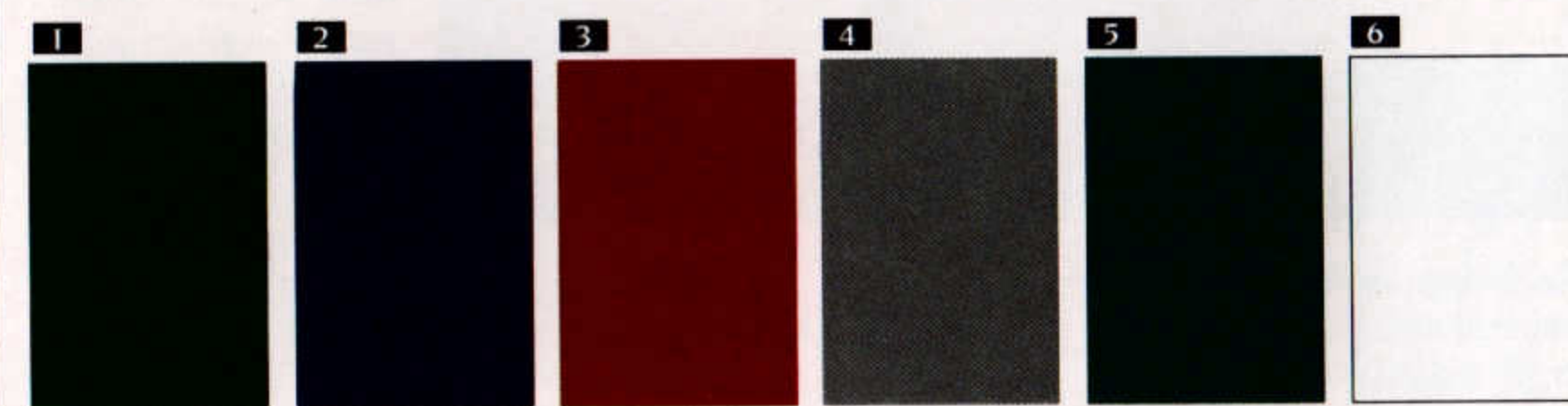

⁽¹⁾Available on SE model only.
Note: Due to printing limitations, the colors shown will vary slightly from actual hues. See your Dodge dealer for actual color chips.

Chrysler Corporation Limited Warranty Protection.

Every Dodge vehicle is covered by Chrysler Corporation's Owner's Choice Protection Plan.*

- A 12-Month or 12,000-Mile (12/12) Basic Limited Warranty* with a Seven-Year or 70,000-Mile (7/70) Power Train Limited Warranty.*
- Or choose a Three-Year or 36,000-Mile (3/36) Basic Bumper-to-Bumper Limited Warranty.*
- In addition, Cummins Intercooled Turbo Diesel models feature an exclusive Seven-Year or 100,000-Mile Engine Warranty.*
- Ram 50 is covered by a 12-Month or 12,000-Mile Limited Warranty* with a Seven-Year or 70,000-Mile (7/70) Power Train Limited Warranty.* Or you can choose a Three-Year or 36,000-Mile (3/36) Bumper-To-Bumper Limited Warranty* with a Five-Year or 60,000-Mile (5/60) Power Train Limited Warranty.*

* See your dealer for details and restrictions on these limited warranties.

Physically Challenged Assistance Program

Cash reimbursements of up to \$500 for purchase and installation of adaptive driving aids or passenger equipment on new 1993 Chrysler Corporation cars, trucks or vans. For further information, contact your dealer or the PHYSICALLY CHALLENGED RESOURCE CENTER AT 1-800-255-9877.

Mopar Customer Care.

There's only one sure way to keep your Dodge car or truck performing at its optimum mile after mile. Just make sure it's serviced regularly at your nearby Dodge dealer. That's where you'll find first-rate mechanics specially trained in the maintenance and repair of your new Dodge. They've been provided with all the sophisticated equipment today's cars and trucks demand. And they have immediate access to a complete stock of genuine Mopar replacement parts that can make the difference between trouble-free driving and the unacceptable alternative.

Mopar Parts.

Mopar parts are engineered by Chrysler Corporation for use in your new Dodge truck. When replacement is necessary, be sure to specify Mopar parts—used by professional mechanics all over the world. Additionally, Mopar offers a wide line of work and style-oriented accessories for pickups. See your dealer for a complete list. Dodge and Mopar are registered trademarks. Ram Pickup, Dakota Pickup, Ramcharger and Ram 50 Pickup are trademarks of Chrysler Corporation.

Chrysler Credit—The Financing And Lease Professionals.

Chrysler Financing/Chrysler Credit offers a variety of finance programs that can help make your new Dodge truck even more affordable. These flexible finance and lease programs can be tailored to suit your budget and your lifestyle. They include Advantage: Gold Key Lease, Gold Key Plus, College Graduate, Retail Financing, and other special payment plans. Ask your salesperson for details.

Chrysler Service Contracts.

Additional peace-of-mind protection for vehicle owners is available through optional Chrysler Service Contracts. These services are available in a variety of time and mileage combinations to meet your particular driving needs.

Dodge Reminds You To "Tread Lightly."

Dodge urges that all off-road vehicles be used with an appreciation of the natural beauty and resources of our land. Practicing "Tread Lightly" policies helps to protect nature, ensuring that it will be ours to enjoy for many years to come. Dodge supports the U.S. Forest Service's "Tread Lightly" program and reminds you that when you go off road, go easy on the environment.



Specifications, descriptions and illustrative materials contained herein are as accurate as known at the time this publication was approved for printing. Chrysler Corporation reserves the right to discontinue models or options at any time or change specifications without notice or without incurring obligation. All options are required in combination with other options. For the price of the model with the equipment you desire, or verification of specifications contained here, see your Dodge Truck dealer.

About this catalog. Since the time of printing, some of the information you'll find in this catalog may have been updated. Ask your dealer for details. Some of the equipment shown or described throughout this catalog is available at extra cost.

(Form no. 74-383-9305) 8/92 500M litho in USA

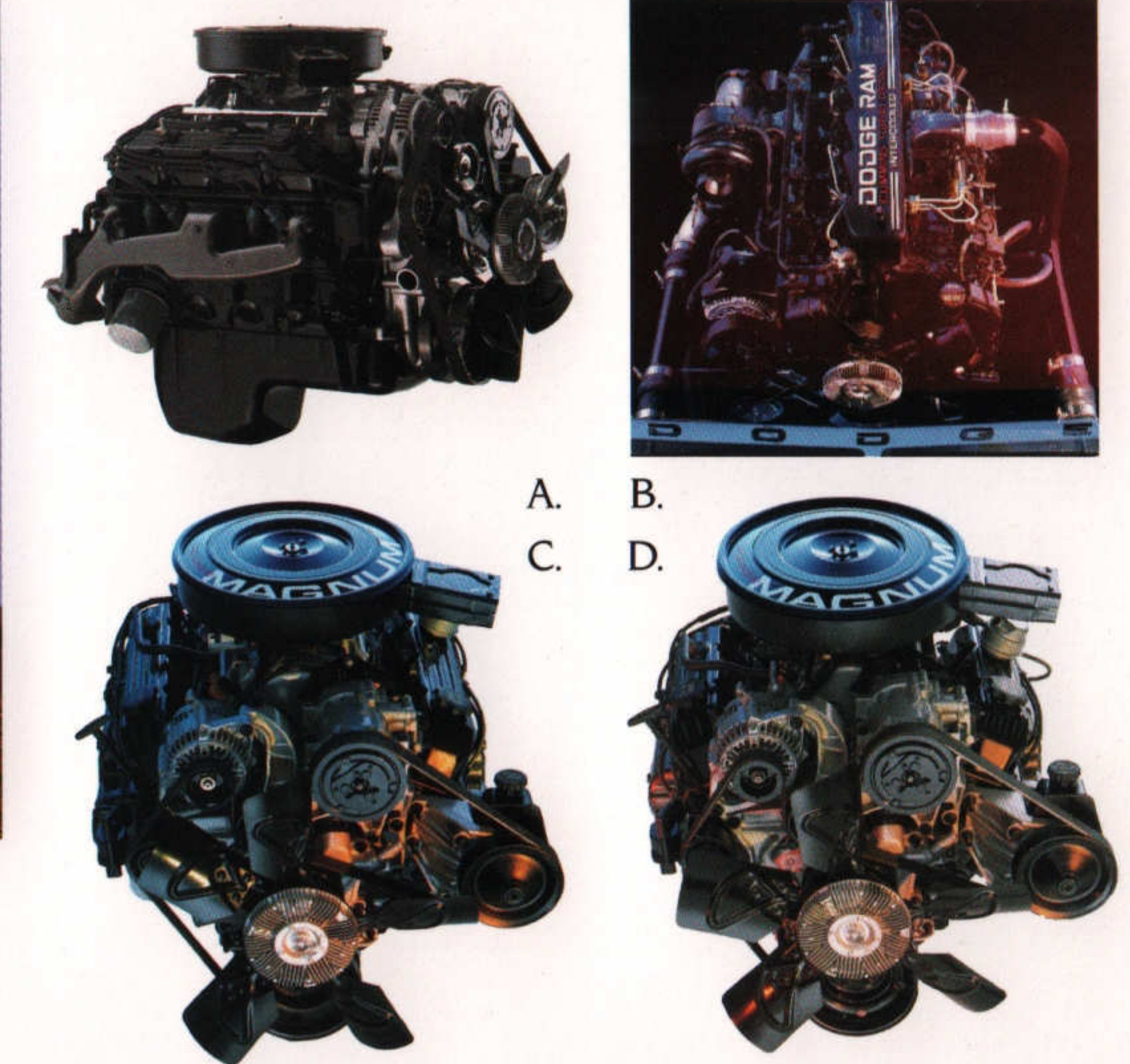

A. MAGNUM 5.9-Liter V8 B. MAGNUM 5.9-Liter Cummins Turbo Diesel
C. MAGNUM 5.2-Liter V8 D. MAGNUM 3.9-Liter V6

Ram Pickups Trailer Towing Specifications

TRUCK MODEL AND MAXIMUM TONGUE WEIGHT (Pounds)	ENGINE AND TRANSMISSION	REAR AXLE RATIO	PAYLOAD OR GVW PACKAGE (Pounds)	MAXIMUM TRAILER WEIGHT ⁽¹⁾ (Pounds)	MAX GCWR (Pounds)
D150 4x2 Pickups, Regular Cab Tongue Wt. 700	MAGNUM 3.9L V6 Man. 5-sp H.D. Auto. 4-sp H.D. O.D.	3.55/3.90 3.55	All All	3,600/4,200 5,000	7,500/8,000 8,800
	MAGNUM 5.2L V8 Man. 5-sp H.D. Auto. 4-sp H.D. O.D.	3.90 3.55/3.90	All All	8,500 7,500/8,500	12,500 11,500/12,500
	MAGNUM 5.9 V8 Man. 5-sp H.D. Auto. 4-sp O.D. H.D.	3.55/3.90 3.55/3.90	All All	8,000 8,000/9,000	12,000 12,000/13,000
D150 4x2 Pickups, Club Cab Tongue Wt. 700	MAGNUM 5.2L V8 Man. 5-sp H.D. Auto. 4-sp O.D. H.D.	3.55 3.55/3.90	6,200 6,200	7,200 7,200/8,200	11,500 11,500/12,500
	MAGNUM 5.9L V8 Man. 5-sp H.D. Auto. 4-sp O.D. H.D.	3.55/3.90 3.55/3.90	6,200 6,200	7,700 7,700/8,700	12,000 12,000/13,000
D250 4x2 Pickups, Regular Cab Tongue Wt. 900	MAGNUM 3.9L V6 Man. 5-sp H.D. Auto. 3-sp	4.10 3.90	All All	5,000 5,100	9,200 9,200
	MAGNUM 5.2L V8 Man. 5-sp H.D. Auto. 4-sp O.D. H.D.	4.10 3.90/4.10	All All	7,200 8,200/8,700	11,500 12,500/13,000
	MAGNUM 5.9L V8 Man. 5-sp H.D. Auto. 4-sp O.D. H.D.	4.10 3.90/4.10 4.10	All 7,400/7,400 8,510	9,100 8,700/9,200 9,100	13,000 13,000/13,500 13,500
D250 4x2 Pickups, Club Cab Tongue Wt. 900	MAGNUM 3.9L V6 Man. 5-sp H.D. Auto. 3-sp	4.10 3.90	All All	5,000 5,100	9,200 9,200
	MAGNUM 5.2L V8 Man. 5-sp H.D. Auto. 4-sp O.D. H.D.	4.10 3.90/4.10	All All	7,200 8,200/8,700	11,500 12,500/13,000
	MAGNUM 5.9L V8 Man. 5-sp H.D. Auto. 4-sp O.D. H.D.	4.10 3.90/4.10 4.10	All 7,400/7,400 8,510	9,100 8,700/9,200 9,100	13,000 13,000/13,500 13,500
D350 4x2 Pickups, Regular Cab Single-Rear Wheels Tongue Wt. 1,000	Cummins 5.9L I-6 Diesel Man. 5-sp O.D. H.D. Auto. 4-sp O.D. H.D. with Super-Duty Cooler	3.07/3.54 4.10 3.54/4.10 3.54	8,510 8,510 8,510 8,510	10,900 11,900 7,000 9,000	16,000 17,000 12,000 14,000
	MAGNUM 5.2L V8 Man. 5-sp H.D. Auto. 4-sp O.D. H.D.	4.10 3.90/4.10	7,400 7,400/7,400	6,900 7,900/8,400	11,500 11,500/13,000
	MAGNUM 5.9L V8 Man. 5-sp H.D. Auto. 4-sp O.D. H.D.	3.54/4.10 3.90/4.10	7,400/All 7,400/All	7,400/8,900 8,400/8,900	12,000/13,500 13,000/13,500
D350 4x2 Pickups, Regular Cab Dual-Rear Wheels Tongue Wt. 1,200	Cummins 5.9L I-6 Diesel Man. 5-sp O.D. H.D. Auto. 4-sp O.D. H.D. with Super-Duty Cooler	3.07/3.54 4.10 3.54/4.10 3.54	8,510 8,510 8,510 8,510	10,600 11,600 6,700 8,700	16,000 17,000 12,000 14,000
	MAGNUM 5.9L V8 Man. 5-sp H.D. Auto. 4-sp O.D. H.D.	4.10/4.56 4.10	8,700/8,700 8,700	9,000/10,500 9,000	13,500/15,000 13,500
	Cummins 5.9L I-6 Diesel Man. 5-sp O.D. H.D. Auto. 4-sp O.D. H.D. with Super-Duty Cooler	3.54/4.10 3.54/4.10 3.54	8,700 8,700 8,700	10,900/11,900 7,000 9,000	16,000/17,000 12,000 14,000
D350 4x2 Pickups, Club Cab Dual-Rear Wheels Tongue Wt. 1,200	MAGNUM 5.9L V8 Man. 5-sp H.D. Auto. 4-sp O.D. H.D.	4.10/4.56 4.10/4.56	10,100 10,100	8,700/10,200 8,700/9,200	13,500/15,000 13,500/14,000
	Cummins 5.9L I-6 Diesel Man. 5-sp O.D. H.D. Auto. 4-sp O.D. H.D. with Super-Duty Cooler	3.54/4.10 3.54/4.10 3.54	10,100 10,100 10,100	10,700/11,700 6,800 8,800	16,000/17,000 12,000 14,000
D350 4x2 Pickups, Club Cab Dual-Rear Wheels Tongue Wt. 1,200	MAGNUM 5.9L I-6 Diesel Man. 5-sp O.D. H.D.	3.54	10,100	10,400	16,000
	Auto. 4-sp O.D. H.D. with Super-Duty Cooler	4.10 3.54/4.10 3.54	10,100 10,100 10,100	11,400 6,500 8,500	17,000 12,000 14,000
W150 4x4 Pickups, Regular Cab	MAGNUM 3.9L V6 Man. 5-sp H.D. Auto. 4-sp O.D.	3.55/3.90 3.55/3.90	6,400 6,400	7,100/8,800 7,100/4,900	11,500/8,000 11,500/9,200
	MAGNUM 5.2L V8 Man. 5-sp H.D. Auto. 4-sp O.D. H.D.	3.55/3.90 3.55/3.90	6,400/All 6,400/6,400	7,100/8,100 7,100/8,100	11,500/12,500 11,500/12,500
Tongue Wt. 700	MAGNUM 5.9L V8 Man. 5-sp H.D. Auto. 4-sp O.D. H.D.	3.55/3.90 3.55/3.90	6,400 6,400/6,400	7,500 7,000/8,000	12,000/12,000 11,500/12,500
	MAGNUM 5.2L V8 Man. 5-sp H.D. Auto. 4-sp O.D. H.D.	3.55/3.90 3.55/3.90	6,400/6,400 6,400/6,400	6,800/7,800 6,700/7,700	11,500/12,500 11,500/12,500

TRUCK MODEL AND MAXIMUM TONGUE WEIGHT (Pounds)	ENGINE AND TRANSMISSION	REAR AXLE RATIO	PAYLOAD OR GVW PACKAGE (Pounds)	MAXIMUM TRAILER WEIGHT ⁽¹⁾ (Pounds)	MAX GCWR (Pounds)
W150 4x4 Pickups, Club Cab Tongue Wt. 700	MAGNUM 5.9L V8 Man. 5-sp H.D. Auto. 4-sp O.D. H.D.	3.55/3.90 3.55/3.90	6,400/6,400 6,400/6,400	7,100/8,100 7,100/8,100	12,000/12,000 12,000/13,000
	MAGNUM 5.2L V8 Man. 5-sp H.D. Auto. 4-sp O.D. H.D.	4.10 3.90/4.10	All All	6,800 7,800/8,300	11,500 12,500/13,000
Tongue Wt. 900	MAGNUM 5.9L V8 Man. 5-sp H.D.	3.54	7,500	7,200	12,000
	Auto. 4-sp O.D. H.D.	4.10 3.90 4.10	7,500/8,510 7,500 7,500/8,510	8,700 8,300 8,700	13,500 13,000 13,500
	Cummins 5.9L I-6 Diesel Man. 5-sp O.D. H.D. Auto. 4-sp O.D. H.D. with Super-Duty Cooler	3.07/3.54 4.10 3.54/4.10 3.54	8,510 8,510 8,510 8,510	10,400 11,400 6,500 8,500	16,000 17,000 12,000 14,000
W250 4x4 Pickups, Club Cab Tongue Wt. 900	MAGNUM 5.2L V8 Man. 5-sp O.D. H.D. Auto. 4-sp O.D. H.D.	4.10 3.90/4.10	7,500 7,500	6,400 7,500/8,000	11,500 12,500/13,000
	MAGNUM 5.9L V8 Man. 5-sp H.D. Auto. 4-sp O.D. H.D.	4.10 3.90 4.10	7,500/8,510 7,500 7,500/8,510	8,500 8,000 8,500	13,500 13,000 13,500
	Cummins 5.9L I-6 Diesel Man. 5-sp O.D. H.D. Auto. 4-sp O.D. H.D. with Super-Duty Cooler	3.07/3.54 4.10 3.54/4.10 3.54	8,510 8,510 8,510 8,510	10,100 11,100 6,200 8,200	16,000 17,000 12,000 14,000
W350 4x4 Pickups, Regular Cab Single-Rear Wheels Tongue Wt. 1,000	MAGNUM 5.9L V8 Man. 5-sp H.D.	4.10/4.56	8,700	8,600/10,000	13,500/15,000
	Auto. 4-sp O.D. H.D.	4.10	8,700	8,600	13,500
	Cummins 5.9L I-6 Diesel Man. 5-sp O.D. H.D. Auto. 4-sp O.D. H.D. with Super-Duty Cooler	3.54/4.10 3.54/4.10 3.54	8,700 8,700 8,700	10,400/11,400 6,500 8,500	16,000/17,000 12,000 14,000
W350 4x4 Pickups, Regular Cab Dual-Rear Wheels Tongue Wt. 1,200	MAGNUM 5.9L V8 Man. 5-sp H.D. Auto. 4-sp O.D. H.D.	4.10/4.56 4.10	10,100 10,100	8,300/9,700 8,300	13,500/15,000 13,500
	Cummins 5.9L I-6 Diesel Man. 5-sp O.D. H.D. Auto. 4-sp O.D. H.D. with Super-Duty Cooler	3.54/4.10 3.54/4.10 3.54	10,100 10,100 10,100	10,200/11,200 6,300 8,300	16,000/17,000 12,000 14,000
	MAGNUM 5.9L I-6 Diesel Man. 5-sp O.D. H.D. Auto. 4-sp O.D. H.D. with Super-Duty Cooler	3.54/4.10 3.54/4.10 3.54	10,100 10,100 10,100	9,900/10,900 6,100 8,100	16,000/17,000 12,000 14,000

⁽¹⁾Maximum Trailer Weight Ratings include cargo and fluids in the trailer and must be decreased by the weight of optional equipment, trailer hitch, cargo in the truck, and passengers other than the driver.

Ram Pickup Driveline Combinations

Model	Engine	TRANSMISSION AVAILABILITY			
		5-Speed Manual	Getrag H.D. 5-sp. Man.	3-Speed Auto.	4-Speed Auto.
D150	MAGNUM 3.9L V6	S		E	
	MAGNUM 5.2L V8	S			E
	MAGNUM 5.9L V8	E			E
D150 Club Cab	MAGNUM 5.2L V8	S			E
D250	MAGNUM 3.9L V6	S		E	
	MAGNUM 5.2L V8	E			E
D250 and D250 Club Cab	MAGNUM 5.9L V8	E			E
	Cummins 5.9L I-6 Turbo Diesel	E	E		E
D350	MAGNUM 5.9L V8	S			E
	Cummins 5.9L I-6 Turbo Diesel		E		E
D350 Club Cab	Cummins 5.9L I-6 Turbo Diesel		S		E

Ram Pickup Driveline Combinations (cont.)

Model	Engine	TRANSMISSION AVAILABILITY			
		5-Speed Manual	Getrag H.D. 5-sp. Man.	3-Speed Auto.	4-Speed Auto.
W150	MAGNUM 3.9L V6	S			E
	MAGNUM 5.2L V8	E			E
	MAGNUM 5.9L V8	E			E
W150 Club Cab	MAGNUM 5.2L V8	S			E
	MAGNUM 5.9L V8	E			E
W250	MAGNUM 5.2L V8	S			E
	MAGNUM 5.9L V8	E			E
	MAGNUM 5.9L I-6 Turbo Diesel		E		E
W250 Club Cab	MAGNUM 5.2L V8	S			E
	MAGNUM 5.9L V8	E	E		E
W350	MAGNUM 5.9L V8	S		E	E
	MAGNUM 5.9L I-6 Turbo Diesel		E		E
W350 Club Cab	MAGNUM 5.9L I-6 Turbo Diesel		S		E

Dakota Trailer Towing Specifications

TRUCK MODEL AND MAXIMUM TONGUE WEIGHT (Pounds)	ENGINE AND TRANSMISSION	REAR AXLE RATIO	PAYLOAD OR GVW PACKAGE (Pounds)	MAXIMUM TRAILER WEIGHT ⁽¹⁾ (Pounds)	MAX GCWR (Pounds)
Dakota 4x2 Regular Cab	2.5L I-4 ⁽²⁾ Man. 5-sp O.D.	3.90	1,250, 1,800	2,800	5,800
	MAGNUM 3.9L V6 Man. 5-sp O.D. Auto. 4-sp O.D.	3.90	All	5,600 5,800	8,800 9,200
Payload Tongue Wt. 1,250 400 1,800 700 2,550 800	MAGNUM 5.2L V8 Auto. 4-sp O.D.	3.90	All	6,900	10,500
	Dakota 4x2 Club Cab	2.5L I-4 ⁽²⁾ Man. 5-sp O.D.	3.90	1,450	2,500
Payload Tongue Wt. 1,450 700 2,000 800	MAGNUM 3.9L V6 Man. 5-sp O.D. Auto. 4-sp O.D.	3.90	All	5,300 5,600	8,800 9,200
	Dakota 4x4 Regular Cab	MAGNUM 5.2L V8 Auto. 4-sp O.D.	3.90	All	6,700
Payload Tongue Wt. 1,450 700 2,000 800	MAGNUM 3.9L V6 Man. 5-sp O.D. Auto. 4-sp O.D.	3.90	1,450, 2,000	5,300 5,600	8,800 9,200
	Dakota 4x4 Club Cab	MAGNUM 5.2L V8 Auto. 4-sp O.D.	3.90	1,450, 2,000	6,600
Payload Tongue Wt. 1,450 700 1,800 800	MAGNUM 3.9L V6 Man. 5-sp O.D. Auto. 4-sp O.D.	3.90	All	4,900 5,200	8,800 9,200
	MAGNUM 5.2L V8 Auto. 4-sp O.D.	3.90	1,450, 1,800	6,100 6,400	9,200 10,500

⁽²⁾ 2.5-liter maximum frontal area equals 32 sq. ft.

⁽¹⁾Maximum Trailer Weight Ratings include cargo and fluids in the trailer and must be decreased by the weight of optional equipment, trailer hitch, cargo in the truck, and passengers other than the driver.

Dakota Driveline Combinations

Model	Engine	TRANSMISSION AVAILABILITY		
		5-Spd. Manual	4-Spd. Auto.	4-Spd. Auto. H.D.
Dakota "S"	2.5L I-4	S		
Dakota and Dakota Club Cab 4x2	2.5L I-4	S		
	MAGNUM 3.9L V6	E	E	
Dakota and Dakota Club Cab 4x4	MAGNUM 5.2L V8			E
	MAGNUM 3.9L V6	S	E	
Dakota Club Cab 4x4	MAGNUM 5.2L V8			E

Ramcharger Trailer Towing Specifications

TRUCK MODEL AND MAXIMUM TONGUE WEIGHT (Pounds)	ENGINE AND TRANSMISSION	REAR AXLE RATIO	PAYLOAD OR GVW PACKAGE (Pounds)	MAXIMUM TRAILER WEIGHT ⁽¹⁾ (Pounds)	MAX GCWR (Pounds)
Ramcharger 4x2 Tongue Wt. 800	MAGNUM 5.2L V8 Auto. 4-sp O.D. H.D.	3.55 3.90	5,600 5,600	7,000 7,500 ⁽²⁾	11,500 12,500
	MAGNUM 5.9L V8 Auto. 4-sp O.D. H.D.	3.55 3.90	6,000, 6,400 6,000, 6,400	6,700 7,500 ⁽²⁾	11,500 13,000
Ramcharger 4x4 Tongue Wt. 800	MAGNUM 5.2L V8 Auto. 4-sp O.D. H.D.	3.55 3.90	6,000, 6,400 6,000, 6,400	6,700 7,500 ⁽²⁾	11,500 12,500
	MAGNUM 5.9L V8 Auto. 4-sp O.D. H.D.	3.55 3.90	6,000, 6,400 6,000, 6,400	7,100 7,500 ⁽²⁾	12,000 13,000

⁽¹⁾Maximum Trailer Weight Ratings include cargo and fluids in the trailer and must be decreased by the weight of optional equipment, trailer hitch, cargo in the truck, and passengers other than the driver.

⁽²⁾Maximum trailer weight for Ramcharger models with this engine and axle ratio is determined by vehicle handling characteristics rather than GCWR. The tow vehicle may have optional equipment, cargo and passengers without reducing the maximum trailer weight if the GCWR is not exceeded.

Ramcharger Driveline Combinations

Model	Engine	TRANSMISSION AVAILABILITY	
		4-Spd. Automatic O.D.	
Ramcharger S 4x2/4x4	MAGNUM 5.2L V8	S	
	MAGNUM 5.9L V8	S	
Ramcharger 4x2/4x4	MAGNUM 5.2L V8	S	
	MAGNUM 5.9L V8	E	

Ram 50 Pickups Trailer Towing Specifications

TRUCK MODEL AND MAXIMUM TONGUE WEIGHT (Pounds)	ENGINE AND TRANSMISSION	REAR AXLE RATIO	PAYLOAD OR GVW PACKAGE (Pounds)	MAXIMUM TRAILER WEIGHT ⁽¹⁾ (Pounds)	MAX GCWR (Pounds)
Ram 50 4x2 Regular Tongue Wt. 350	2.4L I-4 Man. 5-sp O.D. Auto. 4-sp O.D.	3.91 4.22	All All	3,500 3,500	7,175 7,175
	Power Ram 50 4x4 Regular Cab Tongue Wt. 350	2.4L I-4 Man. 5-sp O.D. Auto. 4-sp O.D.	4.22 4.22	All All	3,500 3,500
Ram 50 4x2 Regular Tongue Wt. 350	2.4L I-4 Man. 5-sp O.D. Auto. 4-sp O.D.	3.91 4.22	All All	3,500 3,500	7,175 7,175
	Power Ram 50 4x4 Regular Cab Tongue Wt. 350	2.4L I-4 Man. 5-sp O.D. Auto. 4-sp O.D.	4.22 4.22	All All	3,500 3,500

⁽



OFFICIAL SPONSOR
OF THE 1994 U.S.
OLYMPIC TEAM



"36 USC 380"